



LDK ROD ENDS & SPHERICAL BEARINGS

Rotulas Rotules radials
 Teste a Snodo
 Extremos Roscados Embouts à rotule
 Radial Gelenklager
 Gelenkköpfe und-lager Radial Gelenklager
 Embouts à rotule Rotulas
 Cabezas de rótula
 Rotules radials Snodi Sferici
 Radial Gelenklager Gelenkköpfe und-lager
 Rótulas radials
 Teste a Snodo Gelenkköpfe und-lager
 Extremos Roscados
 Radial Gelenklager
 Cabezas de rótula Rotulas

Rotulas
 Teste a Snodo
 Extremos Roscados
 Snodi Sferici
 Gelenkköpfe und-lager
 Embouts à rotule
 Cabezas de rótula
 Rotules radials
 Radial Gelenklager
Rod End Bearings
&
Spherical Plain Bearings

LDK BEARING MANUFACTURING CO.,LTD

Address: Xipu Industry Park,Luojiang District,Quanzhou Fujian,
P.R.China 362013

TEL: +86-595-28022588 28022688

FAX: +86-595-28023366 28023388

EXPORT SALES OFFICE

TEL: +86-592-5808851 5808852

FAX: +86-592-5808850

Http://www.ldk-bearings.com

E-mail: kzhang@ldk-bearings.com , benjamin@ldk-bearings.com

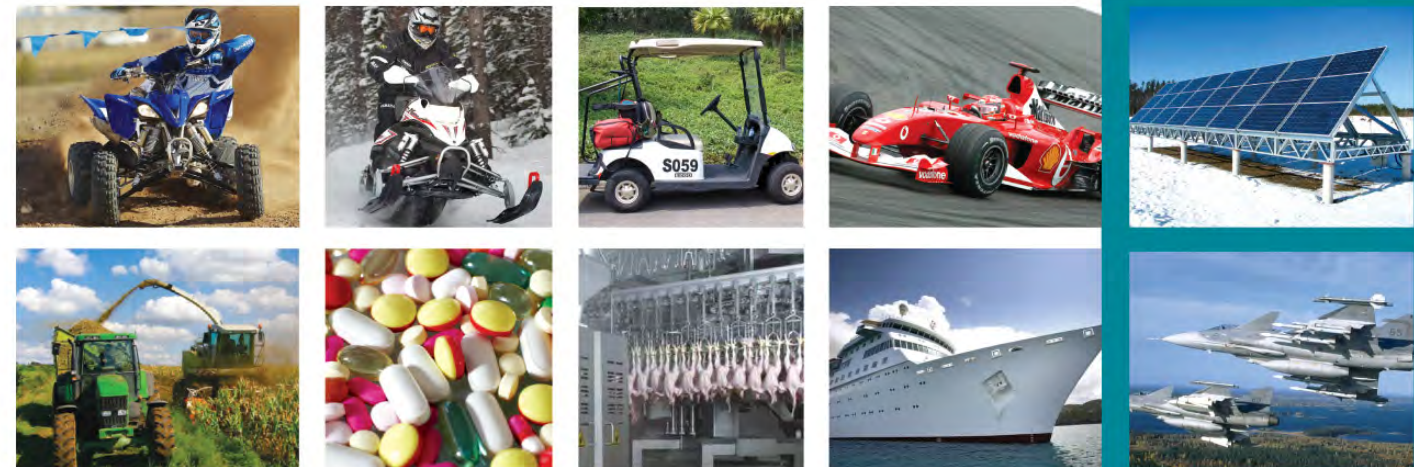



LDK DEYUAN BEARING MANUFACTURING Co.,LTD

LDK Bearings came onto the scene quietly over 10 years ago. They did not make a huge splash, but quickly won the customers over with high quality and very competitive price. **LDK** produces rod ends, spherical plain bearings, ball joints, clevis & yokes, end fittings, torsion bar and custom made linkage products for a wide variety of applications. Over the years, **LDK** Bearings product line has grown to encompass many different industries. From agriculture to transportation, from construction equipment to printing machinery, from textile and packaging machinery to lawn and garden equipments, from recreational and fitness equipment to racing cars. **LDK** can provide cost effective and performance engineered solutions to the most demanding motion transfer needs.

With a growing wealth of engineering and manufacturing expertise on staff, **LDK** is uniquely positioned to partner with its customers in order to provide timely delivery of quality products at a very competitive market price.

LDK is positioned to meet the shifting demands of the global marketplace. It's primary missions are to provide quality products at economic prices and to react quickly to customer requirements. **LDK** can take a project from the initial concept, through design and development, to mass production. The company has set up the quality system and environmental management system according to the international standard of ISO9001 and ISO14001.

Thank you for your interest in **LDK Bearings**.



1. ◆ Assortment of Rod ends and Spherical Bearings
2. ◆ Part A
Engineering Data
3. ◆ Part B
Rod Ends
4. ◆ Part C
Ball Joint Rod Ends, Clevis & End Fittings
5. ◆ Part D
Hydraulic Rod Ends
6. ◆ Part E
All Plastic Polymer Rod Ends
7. ◆ Part F
Spherical Plain Bearings
8. ◆ Part G
Spherical Ball For Rod Ends & Plain Bearings
9. ◆ Part H
Conversion & Interchange Table

LDK[®]



Custom Rod Ends & Spherical Bearings

Beyond the diverse line of catalog items offered by LDK Bearing Company, LDK produces a multitude of products for specific customers with designs and configurations to meet unique requirements. We specialize in providing practical and sound solutions to rod end and spherical bearing application problems and challenges.

From a simple modification of an existing design to a completely unique concept, LDK engineers can give you the ideal configuration for your application.

Some of the options available include:

- Variations in shank or stud length
- Variations in ball bore dimensions
- Enhanced plating or corrosion resistance
- Metric dimensions
- Special materials such as stainless steel
- Sealed rod ends. Seal made by rubber or synthetic materials to give rod end additional protection from contaminants for prolonged life in service.



Assortment of Rod Ends and Spherical Bearings

Rod ends	1-6
Spherical plain bearings	6-10
Clevis/Yokes & End Fittings	10
Spherical Ball	10

Engineering Data

General Information	A1-A3
Temperature	A3
Load Rating	A3-A5
Service life	A6
Angle of Misalignment	A6
Bearing Contact Pressure	A7
Tolerance & Fit	A8-A10
Bearing Internal Clearance	A10-A15
Mounting	A15-A16
Lubrication & Maintenance	A16-A18
Accuracy	A18
Stud Configuration	A19
Warranty & Disclaimer	A19

Metric Rod Ends

PHS	B1
POS	B2
CHS	B3
COS	B4
PHS..EC	B5
POS..EC	B6
PHS..HD	B7
POS..HD	B8
SPHS	B9
SPOS	B10
SCHS	B11
SCOS	B12
SPHS..EC	B13
SPOS..EC	B14
NPHS	B15
NPOS	B16
SI..E&SI..ES	B17
SA..E&SA..ES	B18
SI..C&SI..ET-2RS	B19
SA..C&SA..ET-2RS	B20

Inch Rod Ends *American Size

PHSB	B21
POSB	B22
CF	B23
CM	B24
CF..T	B25
CM..T	B26
CF..TY	B27
CM..TY	B28
F..	B29

M..	B30
JF ..	B31
JM ..	B32
SPHSB..EC	B33
SPOSB..EC	B34
SCF..T(SPHSB..EC)	B35
SCM..T(SPOSB..EC)	B36
CMX.. CMX..T	B37
JFX.. JFX..T	B38
JMX.. JMX..T	B39
RJM.. RJF..	B40
RJMX..T	B41
RRSMX..T	B42
SJF..T	B43
SJM..T	B44
SRSMX..T	B45
HJMX..T	B46
HRSMX..T	B47
PMX..T	B48
RSM.. RSM..T	B49
RSMX.. RSMX..T	B50
NXF..	B51
NXM..	B52
NEXF..	B53
NEXM..	B54
NJF..	B55
NJM..	B56
NAF..	B57
NAM..	B58
ALJF..	B59
ALJM..	B60
ALRSM..	B61

Ball Joint Rod Ends

SQ..RS	C1
SQZ..RS	C2
SQD..	C3
AS..	C4
BS..	C5
CS..	C6
R..G	C7

Clevis / Yokes & End Fittings

Clevis DIN71752 Female	C8
Clevis DIN71752 Male	C9
Yokes DIN71751	C10
Gas Spring Accessories(End Fittings)	
Ball Stud DIN71803	C11
Ball Socket DIN71805	C12

Hydraulic Rod Ends

SK..E & SK..ES	D1
SF..ES	D2
SIR..ES	D3
SIGEW..ES	D4
SIQ..ES	D5

All Plastic Polymer Rod Ends

Engineering Data	E1-E3
PKFM..	E4
PKMM..	E5
PEFM..	E6
PEMM..	E7
PKFI..	E8
PKMI..	E9

Spherical Plain Bearings



GE..E / GE..ES / GE..ES-2RS	F1
GEZ..ES / GEZ..ES-2RS	F2-F3
GEG..E / GEG..ES / GEG..ES-2RS	F4
GEEW..ES	F5
GEEM..ES-2RS	F6
GE..C GEG..C	F7
GEBK..S	F8
GE..PW	F9
GE..ET-2RS GE..XT-2RS	F10
GEG..ET-2RS GEG..XT-2RS	F11
GAC..S	F12
GAC..T	F13
GACZ..S	F14-F15
GX..S	F16
GX..T	F17
COM../HCOM.. COM..T/HCOMT	F18
SCOM.. & SCOM..T	F19
WSSB/WSSB-V	F20
NSSB/NSSB-V	F21
YSSB/YSSB-V	F22
MIB(-T)/AIB(-T)/SIB(-1T)	F23
SGE..ET-2RS	F24
SGE..C	F25
SGE..PW	F26

Spherical Ball For Rod Ends & Plain Bearings

TK Series	G1
CBL...DP Series	G2
HJMX Series	G3
B-GE..C	G4
B-COM	G5

Conversion & Interchange Table

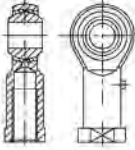
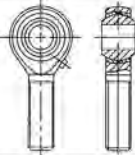
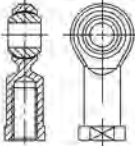
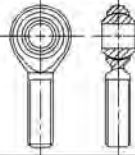
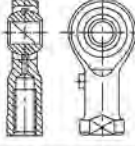
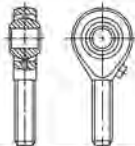
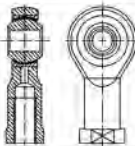
Inch / Metric Conversion Table	H1-H2
Interchange Table	H3-H4

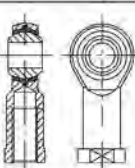
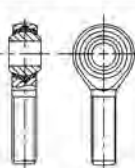

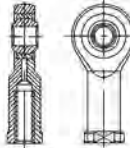
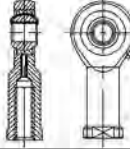
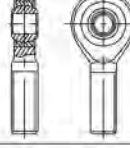
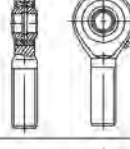
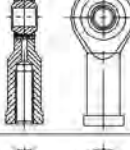
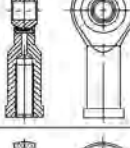
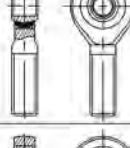
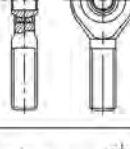
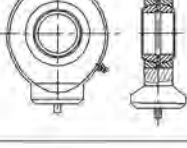
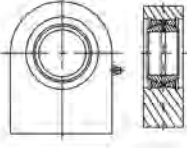
Structure	Series	Size range (mm)	Sliding contact surface	If requiring relubrication	Design characteristics
	PHS	3-30	Steel/Brass	Yes	Inlaid liner rod ends, Prefix "S"=Stainless steel. PHSB in inch dimensions
	SPHS	5-30			
	PHSB	4.82-25.4			
	POS	3-30	Steel/Brass	Yes	Inlaid liner rod ends, Prefix "S"=Stainless steel. POSB in inch dimensions
	SPOS	5-30			
	POSB	4.82-25.4			
	PHS...EC	5-22	Steel/PTFE	No	Extrusion and self-lubricated type of rod ends, Prefix "S"=Stainless steel "B" in inch dimensions
	SPHS...EC	5-22			
	SPHSB...EC	4.82-19.05			
	POS...EC	5-22	Steel/PTFE	No	Extrusion and self-lubricated type of rod ends, Prefix "S"=Stainless steel "B" in inch dimensions
	SPOS...EC	5-22			
	SPOSB...EC	4.82-19.05			
	PHS...HD	5-30	Steel/Brass	Yes	Combination rod ends
	POS...HD	5-30	Steel/Brass	Yes	Combination rod ends
	CHS	3-30	Steel/PTFE	No	Self-lubricated rod ends, Prefix "S"=Stainless steel.
	SCHS	5-30			
	COS	3-30	Steel/PTFE	No	Self-lubricated rod ends, Prefix "S"=Stainless steel.
	SCOS	5-30			
	NPHS	5-30	Steel/Nylon	No	Self-lubricated rod ends, race in Nylon polymer with PTFE additive.
	NPOS	5-30	Steel/Nylon	No	Self-lubricated rod ends, race in Nylon polymer with PTFE additive.

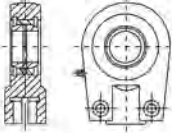
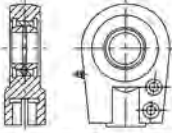
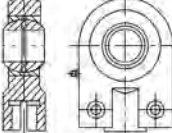
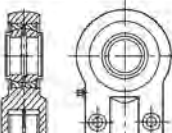
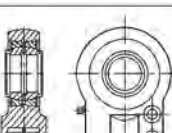
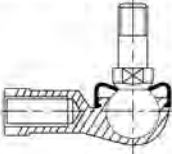
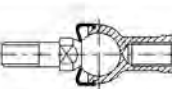
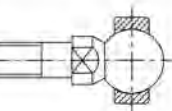
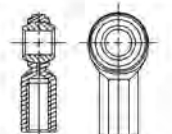
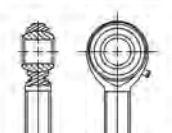
Structure	Series	Size range (mm)	Sliding contact surface	If requiring relubrication	Design characteristics
	SI...E	5-12	Steel/Steel	No	Combination rod ends, mounted with GE..E type of radial spherical plain bearings
	SI...ES SI...ES-2RS	15-80	Steel/Steel	Yes	Combination rod ends, mounted with GE..ES/GE..ES-2RS type of radial spherical plain bearings
	SA...E	5-12	Steel/Steel	No	Combination rod ends, mounted with GE..E type of radial spherical plain bearings
	SA...ES SA...ES-2RS	15-80	Steel/Steel	Yes	Combination rod ends, mounted with GE..ES type of radial spherical plain bearings
	SI...C	5-30	Steel/PTFE	No	Combination rod ends, mounted with GE..C type of radial spherical plain bearings
	SI...ET-2RS	15-80	Steel/PTFE fabric	No	Combination rod ends, mounted with GE..ET-2RS type of radial spherical plain bearings
	SA...C	5-30	Steel/PTFE	No	Combination rod ends, mounted with GE..C type of radial spherical plain bearings
	SA...ET-2RS	15-80	Steel/PTFE fabric	No	Combination rod ends, mounted with GE..ET-2RS type of radial spherical plain bearings
	SK...E SK...ES	10-12 15-80	Steel/Steel	Yes	Stretching rod in fine weldable steel, with slot in the shank and can be clamped by socket screws, combined with GE..ES type of radial spherical plain bearings
	SF...ES	20-120	Steel/Steel	Yes	Stretching rod in fine weldable steel, with dowel pin, combined with GE..ES type of radial spherical plain bearings, housing with a rectangle welding surface



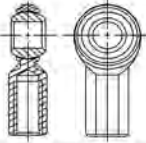
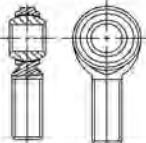

Structure	Series	Size range (mm)	Sliding contact surface	If requiring relubrication	Design characteristics
	SIR...ES ($d \leq 50$)	20-50	Steel/Steel	Yes	Bearings with two slots in the shank and can be clamped by socket screws, right and left thread, combined with GE..ES type of radial spherical plain bearings,
	SIR...ES ($d \geq 60$)	60-120	Steel/Steel	Yes	Bearings with single slots in the shank and can be clamped by socket screws, right and left thread, combined with GE..ES type of radial spherical plain bearings,
	SIQ...ES	12-60	Steel/Steel	Yes	Bearings with two slots in the shank and can be clamped by socket screws, right and left thread, combined with GE..ES type of radial spherical plain bearings,
	SIGEW...ES ($d \leq 50$)	12-50	Steel/Steel	Yes	Bearings with two slots in the shank and can be clamped by socket screws, right and left thread, combined with GEEW..ES type of radial spherical plain bearings
	SIGEW...ES ($d \geq 63$)	63-125	Steel/Steel	Yes	Bearings with single slots in the shank and can be clamped by socket screws, right and left thread, combined with GE..ES type of radial spherical plain bearings,
	SQ...RS	5-22	Steel/Zinc alloy	Yes	Winding shape ball joint rod ends with female thread, housing is made of Zinc alloy.
	SQZ...RS	5-22	Steel/Zinc alloy	Yes	Straight ball joint rod ends with axial shank, female thread, housing is made of Zinc alloy.
	SQD...	5-16	Steel/Zinc alloy	Yes	Ball joint housing is an outer ring of radial spherical plain bearing, made of Zinc alloy
	CF... SCF...	4.82-19.05	Steel/Steel	Yes	Extrusion type of rod ends, Inch dimensions, Prefix "S"=stainless steel
	CM... SCM... CMX...	4.82-19.05	Steel/Steel	Yes	Extrusion type of rod ends, Inch dimensions, Prefix "S"=stainless steel

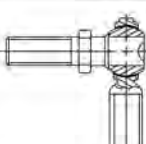
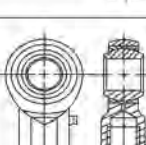
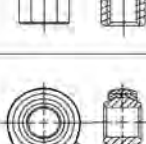
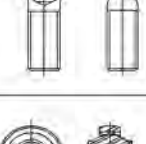
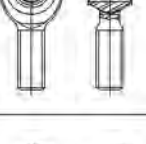
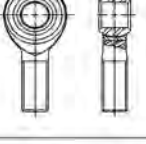

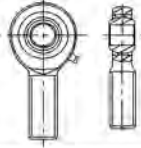
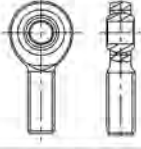
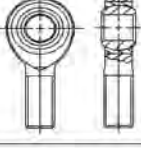
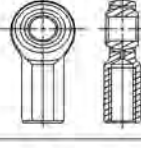
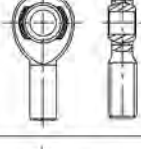
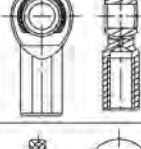
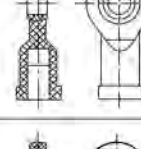
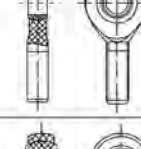
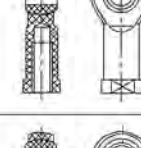
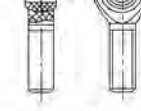
LDK®

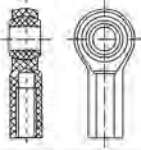
Assortment of Rod Ends and Spherical Plain Bearings

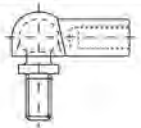
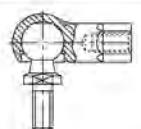
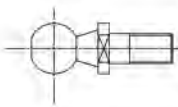
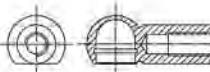
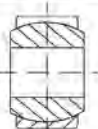
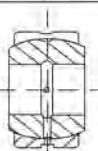
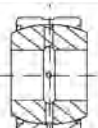

Structure	Series	Size range (mm)	Sliding contact surface	If requiring relubrication	Design characteristics
	CF...T SCF...T	4.82-19.05	Steel/PTFE	No	Extrusion and self-lubricated type of rod ends, Inch dimensions, Prefix "S"=stainless steel
	CM...T SCM...T CMX...T	4.82-19.05	Steel/PTFE	No	Extrusion and self-lubricated type of rod ends, Inch dimensions, Prefix "S"=stainless steel
	CF...TY	10-32 ~ 3/4-16	Steel/PTFE	Yes	Ball joint rod ends, Inch dimensions.
	CM...TY	10-32 ~ 3/4-16	Steel/PTFE	Yes	Ball joint rod ends, Inch dimensions.
	F JF.../JFL... JFX.../JFXL... RJF... ALJF.../ALJFL...	4.82-25.4 4.82-25.4 4.82-25.4 6.35-9.525 4.82-12.7	Steel/Brass Steel/Steel Steel/Steel Steel/Steel Steel/Steel	Yes	Wide alternatives of material for shanks and races for wider application.
	M JM.../JML... JMX.../JMXL... RJM... ALJM.../ALJML...	4.82-25.4 4.82-25.4 4.82-25.4 6.35-9.525 4.82-19.05	Steel/Brass Steel/Steel Steel/Steel Steel/Steel Steel/Steel	Yes	Wide alternatives of material for shanks and races for wider application.
	HJMX...T HRSMX...T	9.52-19.05	Steel/PTFE	No	Wide inner races, PTFE lined.
	RJMX...T SJM...T/SRSM...T HJMX...T PMX...T	9.52-15.88 6.35-19.05 9.52-19.05 7.93-19.05	Steel/PTFE	No	Self-lubricated type, PTFE lined.
	SJF...T	6.35-19.05	Steel/PTFE	No	Self-lubricated type, PTFE lined. Balls, shanks, races are all stainless steel.

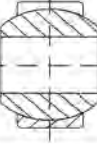
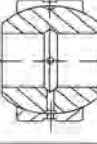
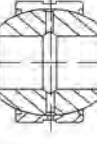
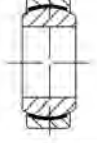
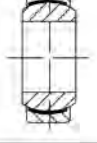
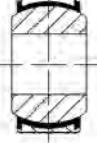
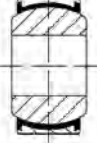

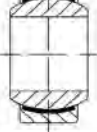
Structure	Series	Size range (mm)	Sliding contact surface	If requiring relubrication	Design characteristics
	RSM... RSMX... ALRSM...	4.82-15.88 4.82-19.05 9.52-12.7	Steel/Steel	Yes	High strength rod ends, Heavy duty shank.
	RSM...T RSMX...T RRSMX...T SRSM...T	4.82-15.88 4.82-22.23 9.52-15.88 9.525-15.88	Steel/PTFE	No	Self-lubricated type, Heavy duty shank.
	NJM...	4.82-19.05	Steel/Nylon	No	Injection-moulded type, race in injected Nylon polymer.
	NJF...	4.82-19.05	Steel/Nylon	No	Injection-moulded type, race in injected Nylon polymer.
	NXM... NEXM... NAM...	4.82-19.05	Steel/Nylon	No	Injection-moulded type, race in injected Nylon polymer for extra axial load capacity.
	NXF... NEXF... NAF...	4.82-19.05	Steel/Nylon	No	Injection-moulded type, race in injected Nylon polymer for extra axial load capacity.
	PEFM..	4-30	Plastic/Plastic	No	All plastic polymer rod ends, body and ball are manufactured from high quality engineering plastic polymer.
	PEMM..	5-30	Plastic/Plastic	No	All plastic polymer rod ends, body and ball are manufactured from high quality engineering plastic polymer.
	PKFM..	2-30	Plastic/Plastic	No	All plastic polymer rod ends, body and ball are manufactured from high quality engineering plastic polymer.
	PKMM..	5-30	Plastic/Plastic	No	All plastic polymer rod ends, body and ball are manufactured from high quality engineering plastic polymer.

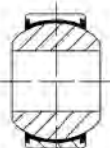
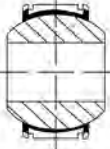
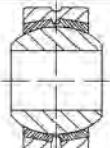
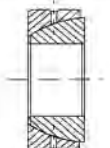
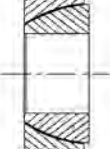
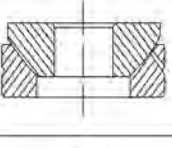
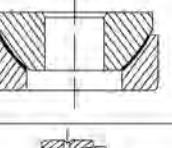
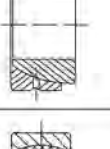
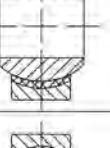
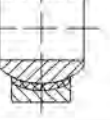
Structure	Series	Size range (mm)	Sliding contact surface	If requiring relubrication	Design characteristics
	PKFI..	4.82-25.4	Plastic/Plastic	No	All plastic polymer rod ends, body and ball are manufactured from high quality engineering plastic polymer.
	PKMI..	4.82-25.4	Plastic/Plastic	No	All plastic polymer rod ends, body and ball are manufactured from high quality engineering plastic polymer.
	AS	6-12	Steel/Nylon	No	Self-lubricated type ball joint rod ends, Race in Nylon polymer.
	BS	5-8	Steel/Nylon	No	Self-lubricated type ball joint rod ends, Body in Nylon polymer with MoS2 additive.
	CS	5-16	Steel/Steel	YES	Body and stud both in carbon steel, Body threaded, The axial clearance and load rating rely on two spring retaining rings.
	BALL STUD DIN71803	8-19	Steel/Steel	YES	Ball stud for CS ball joints. Not assembled for user's convenient installation purpose in special circumstances. The user can decide and create a new way of linkage by selecting ball stud or socket.
	BALL SOCKET DIN71805	8-19	Steel/Steel	YES	Ball socket for CS ball joints. Not assembled for user's convenient installation purpose in special circumstances. The user can decide and create a new way of linkage by selecting ball stud or socket.
	GE...E	4-12	Steel/Steel	NO	Heavy duty, Outer race fractured, inner race hardened.
	GE...ES	15-300	Steel/Steel	YES	Outer race fractured, inner race hardened.
	GEZ...ES	12.7-152.4		YES	Structure same as GE...ES, Inch dimensions.
	GE...ES-2RS	15-300	Steel/Steel	YES	Structure and dimension same as GE...ES, sealed on both sides.
	GEZ...ES-2RS	25-101	Steel/Steel	YES	Structure same as GE...ES-2RS, Inch dimensions.
	GEEW...ES	12-320	Steel/Steel	YES	Outer race fractured, wider inner race, hardened.

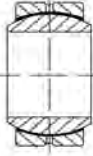
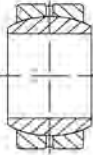
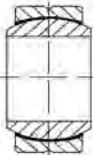
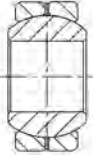
Structure	Series	Size range (mm)	Sliding contact surface	If requiring relubrication	Design characteristics
	GEEM...ES-2RS	20-80	Steel/Steel	YES	Outer race fractured, wider inner race, hardened. Seals on both sides.
	GEG...E	4-12	Steel/Steel	NO	Heavy duty, Outer race fractured, inner race hardened.
	GEG...ES	15-280	Steel/Steel	YES	Heavy duty, Outer race fractured, inner race hardened.
	GEG...ES-2RS	15-280	Steel/Steel	YES	Heavy duty, Outer race fractured, inner race hardened. Seals on both sides
	GE...C	4-30	Steel/PTFE	NO	Outer race extruded, inner race surface hard chromium plated. PTFE lined.
	SGE...C	4-30	Steel/PTFE	NO	Complete stainless steel , Outer race extruded, inner race surface hard chromium plated. PTFE lined.
	GE...ET-2RS	15-120	Steel/PTFE fabric	No	Outer race extruded, inner race surface hard chromium plated. Sealed on both size, with PTFE liner, self-lubricated.
	SGE...ET-2RS	15-60	Steel/PTFE	No	Complete stainless steel , Outer race extruded, inner race surface hard chromium plated. Sealed on both size, with PTFE liner, self-lubricated.
	GE...XT-2RS	140-300	Steel/PTFE fabric	No	Outer race axially splited, inner race surface hard chrome plated, seals on both sides, PTFE lined.
	GEG...C	4-30	Steel/PTFE	No	Heavy duty, outer race extruded, wider inner race with bigger chamfer, surface hard chrome plated, PTFE lined.

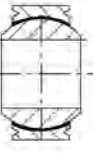
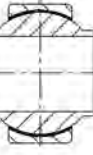
Structure	Series	Size range (mm)	Sliding contact surface	If requiring relubrication	Design characteristics
	GEG...ET-2RS	15-110	Steel/PTFE fabric	No	Heavy duty, Outer race fractured, wider inner race with bigger chamfer, surface hard chrome plated, seals on both sides, PTFE lined.
	GEG...XT-2RS	120-280	Steel/PTFE fabric	No	Heavy duty, outer race splited, wider inner race with bigger chamfer, surface hard chrome plated, seals on both sides, PTFE lined.
	GEBK...S	5-30	Steel/Bronze	Yes	Outer race extruded, inner race surface hard chrome plated.
	GAC...S	25-200	Steel/Steel	Yes	Outer and inner races are separate, both hardened and phosphated.
	GAC...T	25-200	Steel/PTFE fabric	No	Outer and inner races are separate, inner race surface hard chrome plated, PTFE lined.
	GX...S	10-200	Steel/Steel	Yes	Bearing housings and inner races are separate, hardened and phosphated.
	GX...T	10-200	Steel/PTFE fabric	No	Bearing housings and inner races can be split, hardened; inner race surface hard chrome plated, PTFE lined.
	GACZ...S	12.7-152.4	Steel/Steel	Yes	Outer and inner races can be split, both hardened and phosphated. Inch dimensions.
	GE...PW	2-30	Steel/PTFE	No	Outer race extruded, inner race surface hard chrome plated, PTFE lined.
	SGE...PW	5-30	Steel/PTFE	No	Complete stainless steel , Outer race extruded, inner race surface hard chrome plated, PTFE lined.

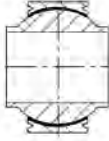
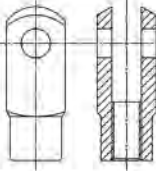
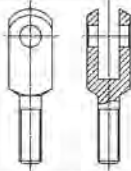
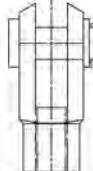
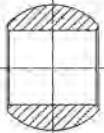
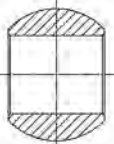
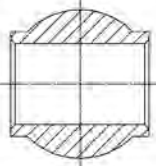
Structure	Series	Size range (mm)	Sliding contact surface	If requiring relubrication	Design characteristics
	COM	4.83-25.4	Steel/Steel	Yes	Outer race alloy steel, with grease groove and holes, inner race surface hard chrome plated. Inch dimensions.
	HCOM	25.4-50.8	Steel/Steel	Yes	
	COM...T	4.83-25.4	Steel/PTFE	No	Outer race alloy steel, PTFE lined, inner race surface hard chrome plated. Inch dimensions.
	HCOM...T	25.4-50.8	Steel/PTFE	No	
	SCOM	4.83-25.4	Steel/Steel	Yes	Outer and inner races are both stainless steel. Inch dimensions.
	SCOM...T	4.83-25.4	Steel/PTFE	No	Outer and inner races are both stainless steel, PTFE composite bonded to I.D of inner race, inner race surface hard chrome plated. Inch dimensions.
	MIB...	4.82-25.4	Steel/Steel	Yes	Inner race heat treated, Hard chrome plated, Outer race extruded, Material in carbon steel (MIB), alloy steel (AIB) and stainless steel (SIB) respectively.
	AIB...				
	SIB...				
	MIB...T	4.82-25.4	Steel/PTFE	No	Outer race extruded, PTFE lined; Outer and inner races for WSSB..., NSSB... are stainless steel.
	AIB...T				
	SIB...T				
	WSSB...				
	NSSB...				
	WSSB...V	4.82-25.4	Steel/PTFE	No	Outer race extruded, with staking grooves, PTFE lined; Outer and inner races are stainless steel.
	NSSB...V				
	YSSB	6.35-19.05	Steel/PTFE	No	Outer race extruded, PTFE lined; Outer and inner races are stainless steel. Inner races extended on both sides.

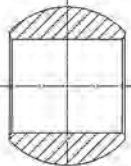
Structure	Series	Size range (mm)	Sliding contact surface	If requiring relubrication	Design characteristics
	YSSB-V	6.35-19.05	Steel/PTFE	No	Outer race extruded, PTFE lined. Outer and inner races are stainless steel. Inner races extended on both sides. With staking grooves on outer races.
	CLEVIS END FEMALE DIN71752	4-16			Used for suspension or drag. It's the main part of the clevis end, can be provided individually upon request. Stainless steel or Steel parts are optional for different application. Steel parts' surface galvanized.
	CLEVIS END MALE DIN71752	6-20			Used for suspension or drag, can be provided individually upon request. Stainless steel or Steel parts are optional for different application. Steel parts' surface galvanized.
	CLEVIS END ASSEMBLY DIN71751	4-16	Steel/Steel		Used for suspension or drag. The two rods connected with this assembly can only swing within same surface. Stainless steel or steel parts are optional for different application. Steel parts' surface galvanized.
	SPHERICAL BALL TK	5-30			Used exclusively for inner race of rod end bearings. Metric series. Stainless steel material is optional for special application.
	SPHERICAL BALL CBL..DP	4.8-25.4			Used exclusively for inner race of rod end bearings. Imperial series. Stainless steel material is optional for special application.
	SPHERICAL BALL HJMX	9.52-19.05			Used in inner race of radial spherical plain bearings. Imperial series. Steps on both ends. Ball surface hard chrome plated. Stainless steel material is optional for special application.
	SPHERICAL BALL B-GE..C	4-30			Used for the inner race of sliding bearing, Metric & Light duty series. Ball surface hard chrome plated. Metric & heavy duty series GEG..C is also available. Stainless steel material is optional for special application.
	SPHERICAL BALL B-COM	4.8-25.4			Used in inner race of radial spherical plain bearing. Imperial series. Ball surface hard chrome plated. Stainless steel material is optional for special application.

1 General Information

1.1 Spherical plain bearings

LDK radial spherical plain bearings have an inner ring with a spherical outside surface and an outer ring with a correspondingly spherical but concave inside surface. Their design makes them particularly suitable for bearing arrangements where alignment movements between shaft and housing have to be accommodated, or where oscillating or recurrent tilting or slewing movements must be permitted at relatively slow sliding speeds. LDK radial spherical plain bearings are available with different sliding contact surface combinations, i.e. the sliding surfaces of inner and outer rings are made from different materials. There are two main groups: spherical plain bearings requiring maintenance (steel-on-steel) and maintenance-free spherical plain bearings.

LDK radial spherical plain bearings requiring maintenance (steel-on-steel) have hardened sliding contact surface on both rings. The surfaces are treated with molybdenum disulphide and phosphated. It has characteristics of wear-resistance and wear-corrosion. Bearings with this sliding contact surface combination require regular relubrication. The high strength of the sliding contact surfaces makes these bearings especially suitable for bearing arrangements where heavy loads of alternating direction, shock loads or heavy static loads have to be accommodated.

LDK maintenance-free spherical plain bearing sliding contact surfaces have three groups: steel-on-PTFE composite material, steel-on-PTFE fabric and steel-on-copper alloy. Dynamic load support capability of steel-on-PTFE fabric spherical plain bearings is higher than that of steel-on-PTFE composite material. They have very low friction and can be operated without maintenance. They are used for applications where long bearing lives are required without maintenance, or where operating conditions, such as inadequate lubrication or the absence of lubrication make the use of steel-on-steel bearing inadvisable.

1.2 Angular Contact Spherical Plain Bearings

The sphered sliding contact surfaces of angular contact spherical plain bearings are inclined at an angle to the bearing axis. They are therefore particularly suitable for carrying combined (radial and axial) loads. A single angular contact spherical plain bearing can only accept axial loads acting in one direction. Under radial loads, a force acting in the axial direction is produced in the bearing which must always be opposed by an equal force acting in the opposite direction. Therefore, the bearings are usually adjusted against a second bearing. When two angular contact spherical plain bearings are arranged so that their sphere centres coincide, a clearance-free radial spherical plain bearing is obtained which can accommodate heavy radial loads as well as heavy axial loads in both directions. LDK angular contact spherical plain bearings are available

with different sliding contact surface combinations, i.e. the sliding surfaces of inner and outer rings are made from different materials. There are two main groups :steel-on-steel angular contact spherical plain bearings and maintenance-free angular contact spherical plain bearings.

LDK steel-on-steel angular contact spherical plain bearings are made of carbon chromium steel and are hardened and phosphated , it has characteristics of wear-resistance and wear-corrosion. The inner and outer rings sliding contact surface are treated with molybdenum disulphide. Bearings with this sliding contact surface combination require regular relubrication. To facilitate efficient lubrication, outer ring has an annular groove and two lubrication holes. The high strength of the sliding surfaces makes these bearings especially suitable for bearing arrangements where heavy loads alternating direction, shock loads or heavy static loads have to be accommodated.

LDK maintenance-free angular contact spherical plain bearings have sliding contact surface combinations steel-on-PTFE fabric, they have very low friction and can be operated without maintenance, any lubrication of the sliding contact surfaces will shorten bearing life. They are used for applications where long bearing lives are required without maintenance, or where operating conditions, such as inadequate lubrication or the absence of lubrication make the use of steel-on-steel bearing inadvisable. The maintenance-free bearings are primarily intended for applications where loads are heavy and have a constant direction.

1.3 Spherical Plain Thrust Bearings

LDK Spherical plain thrust bearings have sliding contact surfaces in the shaft and housing washers which are arranged at an angle to the bearing axis. They are primarily intended for axial loads although they can accommodate combined loads to a certain extent. LDK spherical plain thrust bearings are available with different sliding contact surface combinations, i.e. the sliding surfaces of shaft and housing washers are made from different materials. There are two main group : steel-on-steel spherical plain thrust bearings and maintenance-free spherical plain thrust bearings.

LDK steel-on-steel spherical plain thrust bearings are made of carbon chromium steel and are hardened and phosphated, the shaft and housing washers sliding contact surface are treated with molybdenum disulphide, it has characteristics of wear-resistance and wear-corrosion. Bearings with this sliding contact surface combination require regular relubrication. To facilitate efficient lubrication, housing washer have an annular groove and a lubrication hole. The high wear resistance

of the sliding surfaces makes these bearings especially suitable for bearing arrangements where heavy loads of alternating direction, shock loads or heavy static loads have to be accommodated.

LDK maintenance-free spherical plain thrust bearings have sliding contact surface combinations steel-on-PTFE fabrics they have very low friction and can be operated without maintenance, any lubrication of the sliding contact surfaces will shorten bearing life. They are used for applications where long bearing lives are required without maintenance, or where operating conditions, such as inadequate lubrication or the absence of lubrication make the use of steel-on-steel bearing inadvisable. The maintenance-free bearings are primarily intended for applications where loads are heavy and have a constant direction.

2. Temperature range:

LDK Rod ends and Spherical Plain bearings can be operated within the operating temperatures listed below:

Mating surfaces	Temperature Celsius	Temperature Fahrenheit
Steel/Special Brass	-50° to +200°	-58° to +392°
Steel/Bronze	-50° to +230°	-58° to +446°
Steel/PTFE liner	-50° to +200°	-58° to +392°
Steel/PTFE Glass fibre liner	-30° to +150°	-22° to +302°
Steel/Steel	-50° to +200°	-58° to +392°

Increase of operating temperature occurs a decrease of load capacity of the bearing therefore life will be reduced too.

LDK can manufacture Rod ends and Spherical Plain bearings at a wider and higher temperature range according to customer's special request.

3. Load Rating

3.1 Dynamic Rating

Dynamic Rating is used for calculations when the spherical plain bearing is subjected to dynamic stress. It represents the load, constant in magnitude and direction, under which a basic rating service life, expressed as a sliding distance, will be attained for continuous oscillating movement at a defined sliding velocity and at room temperature. It presupposes that the load acting on radial and angular spherical plain bearings and on rod ends is purely radial and that the load acting on

spherical plain thrust bearings is purely axial and acts centrally. Dynamic stresses occur when tilting, oscillatory or rotational movements are made under load as well as micro sliding movements under alternating loads, e.g resulting from vibration, or loads which alternate at high frequency. The various types of dynamic stress often occur in combination.

The values of load ratings are always dependent on the definition used. It is therefore not always possible to make direct comparisons with load ratings published by other manufactures.

3.2 Static rating

The static load ratings is used when spherical plain bearings stand still under load(or make occasional alignment movements) and it should also be considered when dynamically loaded bearings are subjected to heavy shock loads. The static load rating represents the load which can be taken up by a spherical plain bearing when static contact stress of bearing contact surface reaches the material stress limit. It is valid at room temperature and it is presupposed that surrounding components prevent deformation of the bearing. At higher temperature, the static load rating must be multiplied by a temperature factor, depend on the sliding contact combination. The temperature factor is the same as for dynamically stressed bearing. It is also necessary to take into consideration the permissible temperature rang for the various sliding contact surface combinations.

For rod ends, it is the strength of the rod end housing under stationary load which is considered. The rod end static load ratings give a safety factor of 1.2 times the tensile strength of the rod end housings material.

The ultimate radial static load rating is measured as the failure point when a load is increasingly applied to a pin through the rod end's bore and pulled straight up while the rod end is fixtured. Note that **LDK's** cataloged radial load ratings include a safety factor, and that insertion of a grease fitting into the radius of the rod end may reduce the load rating due to lesser cross-sectional material in the stressed point.

The actual rating is determined by calculating the lowest of the following three values:

1. Race material compressive strength (R value): $R = E \times T \times X$

2. Rod end head strength (H Value, cartridge type construction):

$$H = \left[\left(\frac{T}{2} \sqrt{D^2 - T^2} \right) + \left(\frac{D^2}{2} \times \sin^{-1} \frac{T}{D} \right) - (\text{O.D. of Bearing} \times T) \right] \times X$$

Angle of $\frac{T}{D}$ expressed in radians

3. Shank strength (S Value) Male threaded rod end: $S = [(\text{root diameter of thread}^2 \times .78) - (N^2 \times .78)] \times X$

Female threaded rod end: $S_f = [(J^2 \times .78) + (\text{major diameter of thread}^2 \times .78)] \times X$

Where: E = Ball Diameter

T = Housing Width

X = Allowable Stress (See Table Below)

D = Head Diameter

N = Diameter of Drilled Hole in Shank of Male Rod End

J = Shank Diameter of Female Rod End



The axial static load capacity is measured as the force required to cause failure via a load parallel to the axis of the bore.

Depending on material types and construction methods, the ultimate axial load is generally 10-20% of the ultimate radial static load. The formula does not account for the bending of the shank due to a moment of force, nor the strength of the stake in cartridge-type construction.

AXIAL STRENGTH (A Value): $A = .78 [(E + .176T)^2 - E^2] \times X$

Where: X = Allowable Stress (See Table)

E = Ball Diameter

T = Housing Width

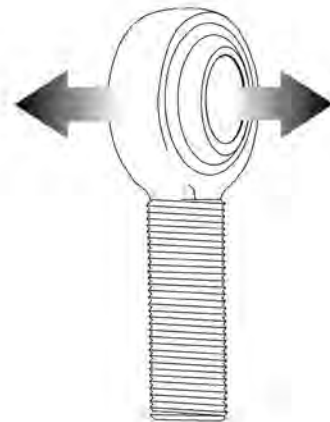

MATERIAL	ALLOWABLE STRESS (PSI)
Brass	30,000
Aluminum	35,000
300 Series Stainless Steel	35,000
low Carbon Steel	52,000
Alloy Steel	140,000

4. SERVICE LIFE

The service life of the spherical plain bearings and rod ends operated under mixed or dry friction conditions is determined by the increase in bearing clearance or bearing friction caused by progressive wear of the sliding surfaces, plastic deformation of the sliding material or fatigue of the sliding surface. Depending on the application, the permissible wear or permissible increase in friction will be different. This means that under the same operating conditions the service life which can be obtained in practice will be different.

The service life of a spherical plain bearing is the number of oscillating movements, or the number of operating hours, which the bearing will service before a defined increase in bearing clearance or a defined increase in friction is reached.

The effective service life is that life which will be attained by a given spherical plain bearing under actual operating conditions. It is determined by the magnitude and type of load, but also by several other factors, such as contamination, corrosion, high-frequency load and movement cycles, shock etc. Some of these factors are impossible to determine or can only be determined with difficulty.

5. ANGLE OF MISALIGNMENT

The maximum angle of the ball in a rod end or spherical bearing that can be maintained without interference is calculated as the angle of misalignment. It is defined as the angle between the ball centerline and the outer member centerline when the ball is aligned in its extreme position as allowed. The worst case limiting angle is determined by clevis-mounted assembly as seen in Figure 1. Total misalignment under this condition, as cataloged by **LDK** for rod end applications, is twice the angle from one side of center to the opposite extreme position. Misalignment in a spherical bearing is limited by ball and race width, as functions of ball diameter, and is illustrated in Figure 3 on the right. This calculation is the basis for **LDK** catalogue angles of misalignment. Other mounting arrangements as shown in Figures 2-4 can also be used as guidelines in calculating the precise angle of misalignment depending on the mounting configuration, and are frequently referenced for metric usage.

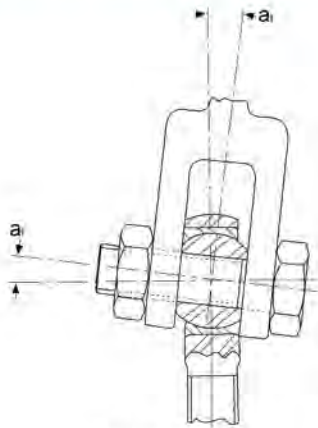

FIGURE 1

$$a^1 = \sin^{-1} \frac{W}{D} - \sin^{-1} \frac{T}{D}$$

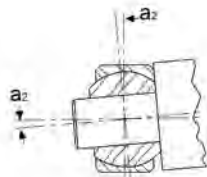

FIGURE 2

$$a^2 = \sin^{-1} \frac{W}{A} - \sin^{-1} \frac{T}{A}$$

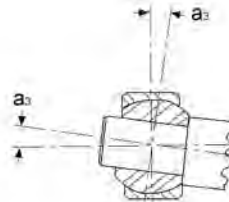

FIGURE 3

$$a^3 = \sin^{-1} \frac{W}{E} - \sin^{-1} \frac{T}{E}$$

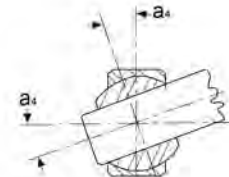

FIGURE 4

$$a^4 = \cos^{-1} \frac{B}{E} - \cos^{-1} \frac{T}{E}$$

Reference Letters

B= Ball Bore

T = Housing Width

M= Outer Race Chamfer

$$A = \sqrt{(D-2M)^2 + T^2}$$

D= Head Diameter of the outer Race Diameter

W = Ball Width

E =Ball Diameter

6. BEARING CONTACT PRESSURE

If an adequate operating life is to be achieved, a basic requirement is that the bearing contact pressure is compatible with the operating conditions. The bearing contact pressure identifies the surface pressure occurring in the bearing and is a decisive criterion for the assessment of a spherical plain bearing in each individual application.

$$p = k \cdot \frac{P_d}{C_d}$$

p=contact pressure N/mm²

k=contact pressure parameter

C =Dynamic load rating kN

p=Equivalent dynamic bearing load kN

Contact surface combination	Value of load ratio C _s /P	Load factor k
Steel/steel	2	100
Steel/brone	2	50
Steel/PTFE fabric	1.75	150
Steel/PTFE composite material	2	100
Steel/copper alloy	2	100

7. TOLERANCE AND FIT

7.1 Tolerance & Fit for Radial spherical plain bearings

Inner ring (except for series GEBK...S*, GE...PW*)

μm

d		Δ dmp		Δ dmp*		Vdp	Vdmp	Vdp*	Vdmp*	Δ Bs		Δ Bs*	
over	Incl.	max	min	max	min	max	max	max	max	max	min	max	min
-	18	0	-8	+18	0	8	6	18	14	0	-120	0	-180
18	30	0	-10	+21	0	10	8	21	16	0	-120	0	-210
30	50	0	-12	+25	0	12	9	25	19	0	-120	0	-250
50	80	0	-15	+30	0	15	11	30	22	0	-150	0	-300
80	120	0	-20	+35	0	20	15	35	26	0	-200	0	-350
120	180	0	-25	+40	0	25	19	40	30	0	-250	0	-400
180	250	0	-30	+46	0	30	23	46	35	0	-300	0	-460
250	315	0	-35	+52	0	35	26	52	39	0	-350	0	-520
315	400	0	-40	+57	0	40	30	57	43	0	-400	0	-570
400	500	0	-45	-	-	45	34	-	-	0	-450	-	-
500	630	0	-50	-	-	50	38	-	-	0	-500	-	-

The deviations in the columns with symbol * apply to spherical plain bearings of series of GEEW...ES.

Outer ring

μm

D		Δ Dmp		VDp	VDmp	Δ Cs	
over	Incl.	max	min	max	max	max	min
-	18	0	-8	10	6	0	-240
18	30	0	-9	12	7	0	-240
30	50	0	-11	15	8	0	-240
50	80	0	-13	17	10	0	-300
80	120	0	-15	20	11	0	-400
120	150	0	-18	24	14	0	-500
150	180	0	-25	33	19	0	-500
180	250	0	-30	40	23	0	-600
250	315	0	-35	47	26	0	-700
315	400	0	-40	53	30	0	-800
400	500	0	-45	60	34	0	-900
500	630	0	-50	67	38	0	-1000
630	800	0	-75	100	56	0	-1100
800	1000	0	-100	135	75	0	-1200

Tolerances for GEBK...S

Inner ring

μm

d		Δ dmp		Δ Bs	
Over	Incl.	max	min	max	min
-	6	+12	0	0	-100
6	10	+15	0	0	-100
10	18	+18	0	0	-100
18	30	+21	0	0	-100

Outer ring

μm

D		Δ Dmp		Δ Cs	
Over	Incl.	max	min	max	min
10	18	0	-11	+100	-100
18	30	0	-13	+100	-100
30	50	0	-16	+100	-100
50	80	0	-19	+100	-100

Tolerances for GE...PW

Inner ring		μm			
d mm		Δdmp		ΔBs	
Over	Incl.	max	min	max	min
-	6	+12	0	0	-100
6	10	+15	0	0	-100
10	18	+18	0	0	-100
18	30	+21	0	0	-100

Outer ring		μm			
D mm		ΔDmp		ΔBs	
Over	Incl.	max	min	max	min
10	18	0	-11	0	-240
18	30	0	-13	0	-240
30	50	0	-16	0	-240
50	80	0	-19	0	-300

The symbols of dimensions and tolerance

- d: Bearing bore diameter, nominal .
- Δdmp: Single plane mean bore diameter deviation.
- Vdp: Bore diameter variation in a single radial plane.
- Vdmp: Mean bore diameter variation.
- ΔBs: Deviation of a single width of the inner ring.
- B: Width of the inner ring, nominal.
- D: Bearing outside diameter, nominal.
- ΔDmp: Single plane mean outside diameter deviation.
- VDp: Outside diameter variation in a single radial plane.
- VDmp: Mean outside diameter variation.
- ΔCs: Deviation of a single width of the outer ring.
- C: Width of outer ring, nominal.
- ΔTs: Actual deviation of width of the angular contact spherical plain bearing.
- ΔHs: Actual deviation of height of the spherical plain thrust bearing.
- Δhs, Δh1s: Center height deviation of rod ends or ball joint rod ends.

7.2 Tolerance & Fits for Rod ends

Inner ring

The Δdmp, ΔBs of SI...E, SI...ES, SA...E, SA...ES, SIR...ES, SIQ...ES, SK...ES, SF...ES, SI...C, SA...C, SI...ET-2RS, SA...ET-2RS are same as radial spherical plain bearings GE...E, GE...ES, GE...C, GE...ET-2RS

The Δdmp, ΔBs of SIGEW...ES are same as radial spherical plain bearings GEEW...ES. PHS..., POS..., PHSB..., POSB..., PHS...EC, POS...EC, PHS...HD, POS...HD, NPHS..., NPOS..., SPHS..., SPOS..., SPHS...EC, SPOS...EC, SCHS..., SCOS.

d		Δdmp		ΔBs	
Over	Incl.	max	min	max	min
-	6	+12	0	0	-150
6	10	+15	0	0	-150
10	12	+18	0	0	-150
12	18	+18	0	0	-200
18	30	+21	0	0	-200

Center height deviation mm

d		Δhs		$\Delta h1s$	
Over	Incl.	max	min	max	min
-	6	+0.80	-1.20	+0.65	-1.05
6	20	+0.80	-1.20	+0.80	-1.20
20	30	+1.00	-1.70	+1.00	-1.70
30	45	+1.40	-2.10	+1.40	-2.10
45	60	+1.80	-2.70	+1.80	-2.70
60	80	+2.25	-3.40	+2.25	-3.40
80	125	+2.70	-3.40	+2.70	-3.40
125	200	+3.20	-4.20	+3.20	-4.20

Tolerances for American size rod ends are indicated in each table enclosed.

8. Bearing Internal Clearance

Bearing internal clearance is defined as the total distance through which one ring can be moved radially (radial internal clearance) or axially (axial internal clearance) in relation to the other ring under a defined measuring load.

It is necessary to distinguish between the internal clearance of a bearing before it is mounted and the internal clearance of a mounted bearing when in operation (operational clearance). The initial clearance will always be greater than the operational clearance because the rings are expanded or compressed by interferences fits and as a result of the differences in thermal expansion of the bearing rings and mating components.

The bearing internal clearance referred to as normal has been selected so that when bearings are mounted generally recommended and operate under normal conditions a suitable operational will be obtained. For other conditions, e.g. where both rings are mounted with an interference fit or where unusual temperatures prevail, bearing with greater or smaller internal clearance than normal may be required.

8.1 Radial internal clearance of radial spherical plain bearings

Radial internal clearance of steel-on-steel radial spherical plain bearings

Series of GE...E, GE...ES, GE...ES-2RS, GEEW...ES, GEEM...ES, GEZ...ES, GEZ...ES-2RS, COM...
COMH..., COM...SS, MIB, AIB, SIB

d		Group		Group		Group	
mm		C2		Normal		C3	
Over	Incl.	min	max	min	max	min	max
-	12	8	32	32	68	68	104
12	20	10	40	40	82	82	124
20	35	12	50	50	100	100	150
35	60	15	60	60	120	120	180
60	90	18	72	72	142	142	212
90	140	18	85	85	165	165	245
140	200	18	100	100	192	192	284
200	240	18	110	110	214	214	318
240	300	18	125	125	239	239	353

Series of GEG...E, GEG...ES, GEG...ES-2RS

d		Group		Group		Group	
mm		C2		Normal		C3	
Over	Incl.	min	max	min	max	min	max
-	10	8	32	32	68	68	104
10	17	10	40	40	82	82	124
17	30	12	50	50	100	100	150
30	50	15	60	60	120	120	180
50	80	18	72	72	142	142	212
80	120	18	85	85	165	165	245
120	160	18	100	100	192	192	284
160	220	18	100	100	192	192	284
220	280	18	110	110	214	214	318

Series of GEBK...S

d		Group		Group		Group	
mm		C2		Normal		C3	
Over	Incl.	min	max	min	max	min	max
2.5	6	4	34	10	50	42	70
6	10	5	41	13	61	52	88
10	18	6	49	16	75	64	107
18	30	7	59	20	92	98	150

Series of GE...C, GE...PW, COM...T, COM...H, COMSS...H, WSSB..., WSSB...V, NSSB..., NSSW...V,
YSSB..., YSSB...V, MIB..., AIB..., SIB...

d		Group	
mm		Normal	
Over	Incl.	min	max
-	12	4	28
12	20	5	35
20	30	6	44

Series of GE...ET-2RS, GE...XT-2RS

d mm		Group	Normal μm
Over	Incl.	min	max
-	20	0	40
20	35	0	50
35	60	0	60
60	90	0	72
90	140	0	85
140	240	0	100
240	300	0	110

Series of GEG...ET-2RS, GEG...XT-2RS

d mm		Group	Normal μm
Over	Incl.	min	max
-	30	0	50
30	50	0	60
50	80	0	72
80	120	0	85
120	220	0	100
220	280	0	110

8.2 Radial internal Clearance of Rod ends

Series of SI...E, SI...ES, SA...E, SA...ES, SIR...RS, SIGEW...ES, SIQ...ES, SK...ES, SF...ES, CM..., CF..., JM..., JML...JF..., JFL..., RJM..., RJF...ALJM..., ALJF..., ALRSM...

d mm		Group C2 μm		Group Normal μm		Group C3 μm	
Over	Incl.	min	max	min	max	min	max
-	12	4	32	16	68	34	104
12	20	5	40	20	82	41	124
20	35	6	50	25	100	50	150
35	60	8	60	30	120	60	180
60	90	9	72	36	142	71	212
90	125	9	85	42	165	82	245
125	200	9	100	50	192	96	284

Series of SI...C, SA...C, SI...ET-2RS, SA...ET-2RS, CHS..., COS..., SCHS..., SCOS..., NPHS..., NPOS..., PHS...EC, POS...EC, SPHS...EC, SPOS...EC, SPHSB...EC, SPOSB...EC, CF...T, CM...T, SCF...T, SCM...T, CMX...T, RJM...T, RRSMX...T, SJM...T, SRSM...T, SJF...T, HJMX...T, PMX...T, NJF..., NJM..., NXF..., NXM..., NEXF..., NEXM..., NAF..., NAM..., RSM...T, RSMX...T, HRSMX...T

d		Group		Group		Group	
mm		C2		Normal		C3	
Over	Incl.	min	max	min	max	min	max
-	12	0	25	0	32	15	45
12	20	0	30	0	40	20	60
20	35	0	35	0	50	25	65
35	60	0	40	0	60	30	80
60	80	0	50	0	72	35	90

Series of PHS..., POS..., PHSB..., POSB..., PHS...HD, POS...HD, SPHS..., SPOS..., M..., F...

d		Group		Group		Group	
mm		C2		Normal		C3	
Over	Incl.	min	max	min	max	min	max
2.5	6	2	34	5	50	21	72
6	10	3	41	7	61	26	88
10	18	3	49	8	75	32	107
18	30	4	59	10	92	39	120
30	50	5	71	13	112	49	150

8.3 Fits of radial spherical plain bearings

Shaft fits

Operating conditions	Sliding contact surface of combination	
	Requiring maintenance	Maintenance-free
Loads of all kinds, clearance or transition fit	h6, hardened shaft	h6, g6
Loads of all kinds, interference fit	m6	k6

Housing fit

Operating conditions	Sliding contact surface of combination	
	Requiring maintenance	Maintenance-free
Light loads, Axial displacement required	H7	H7
Heavy loads	M7	K7
Light alloy housings	N7	M7

Shaft diameter tolerances

Shaft diameter mm		Shaft diameter tolerances μm							
		g6		h6		k6		m6	
Over	Incl.	High	Low	High	Low	High	Low	High	Low
3	6	-4	-12	0	-8	+9	+1	+12	+4
6	10	-5	-14	0	-9	+10	+1	+15	+6
10	18	-6	-17	0	-11	+12	+1	+18	+7
18	30	-7	-20	0	-13	+15	+2	+21	+8
30	50	-9	-25	0	-16	+18	+2	+25	+9
50	80	-10	-29	0	-19	+21	+2	+30	+11
80	120	-12	-34	0	-22	+25	+3	+35	+13
120	180	-14	-39	0	-25	+28	+3	+40	+15
180	250	-15	-44	0	-29	+33	+4	+46	+17
250	315	-17	-49	0	-32	+36	+4	+52	+20

Housing bore tolerances

Housing bore diameter(mm)		Housing bore tolerances μm							
		H7		K7		M7		N7	
Over	Incl.	High	Low	High	Low	High	Low	High	Low
10	18	+18	0	+6	-12	0	-18	-5	-23
18	30	+21	0	+6	-15	0	-21	-7	-28
30	50	+25	0	+7	-18	0	-25	-8	-33
50	80	+30	0	+9	-21	0	-30	-9	-39
80	120	+35	0	+10	-25	0	-35	-10	-45
120	180	+40	0	+12	-28	0	-40	-12	-52
180	250	+46	0	+13	-33	0	-46	-14	-60
250	315	+52	0	+16	-36	0	-52	-14	-66
315	400	+57	0	+17	-40	0	-57	-16	-73
400	500	+63	0	+18	-45	0	-63	-17	-80

Fits for rod ends

Shaft fits

Operating conditions	Tolerance
With indeterminate loads	n6, p6
Normal conditions	h6, h7

Thread

Male Thread	Female Thread
6g	6H
UNF-2A	UNF-2B
BSF-free	BSF-normal

Shaft diameter tolerances

Shaft diameter mm		Shaft diameter tolerances							
		h6		h7		n6		p6	
Over	Incl.	High	Low	High	Low	High	Low	High	Low
3	6	0	-8	0	-12	+16	+8	+20	+12
6	10	0	-9	0	-15	+19	+10	+24	+15
10	18	0	-11	0	-18	+23	+12	+29	+18
18	30	0	-13	0	-21	+28	+15	+35	+22
30	50	0	-16	0	-25	+33	+17	+42	+26
50	80	0	-19	0	-30	+39	+20	+51	+32
80	120	0	-22	0	-35	+45	+23	+59	+37
120	180	0	-25	0	-40	+52	+27	+68	+43
180	250	0	-29	0	-46	+60	+31	+79	+50

9. Mounting

Proper press-fitting of spherical bearings into a housing fixture will result not only in smooth bearing performance, but also in better wear characteristics leading to longer life. LDK engineering recommends strict adherence to the following installation procedures in order to assure optimal spherical bearing performance and wear.

The spherical bearings and rod ends must be kept in their original packaging until shortly before their installation, so that they continue to be effectively preserved for as long as possible. Ensure during the installation process that foreign particles are on no account allowed to enter the outer ring of the bearing.

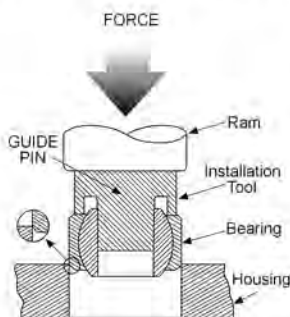

The use of a hydraulic press to apply constant pressure is recommended. Any other shocking-inducing device such as a hammer will result in damage and/or ultimate misfit. An installation tool such as that shown on the left is ideal. Here the guide pin aligns the ball's bore parallel to the race O.D., while all force is applied to the outer race surface only. The force required for installation and removal should on no account be transmitted from the spherical form to the bearing shells or raceways of the bearing outer ring.

STAKING METHOD FOR V-GROOVED SPHERICAL BEARINGS

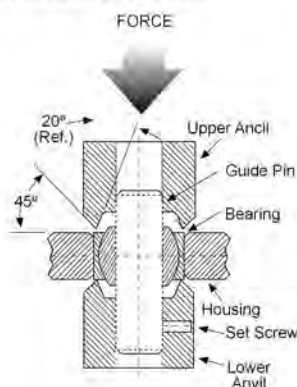

Customers often require a bearing with a specially formed "V"-shaped groove on the face of the outer race, allowing for staking of the bearing into bearing into a fixed outer housing. This is accomplished by forcing the metal on the outside of the groove onto the fixture's face or into its chamfer. The use of hydraulic press for this operation is recommended, as is following the instructions for the initial installation of the bearing into the housing as described above.

LDK Engineering recommends an upper and lower anvil method for installation. Anvils should be aligned as shown, with guide pin in position. This pin should ideally be secured in the lower anvil by means of a set screw. A test assembly should be undertaken to assure that required axial (thrust) load requirements of the final product are maintained. Avoid excessive pressure which can result in distortion leading to premature failure or malfunction. When the test requirements are met, the assembly should be rotated at 90° maximum intervals, with pressure re-applied, to assure uniformity of the metal swaging process.

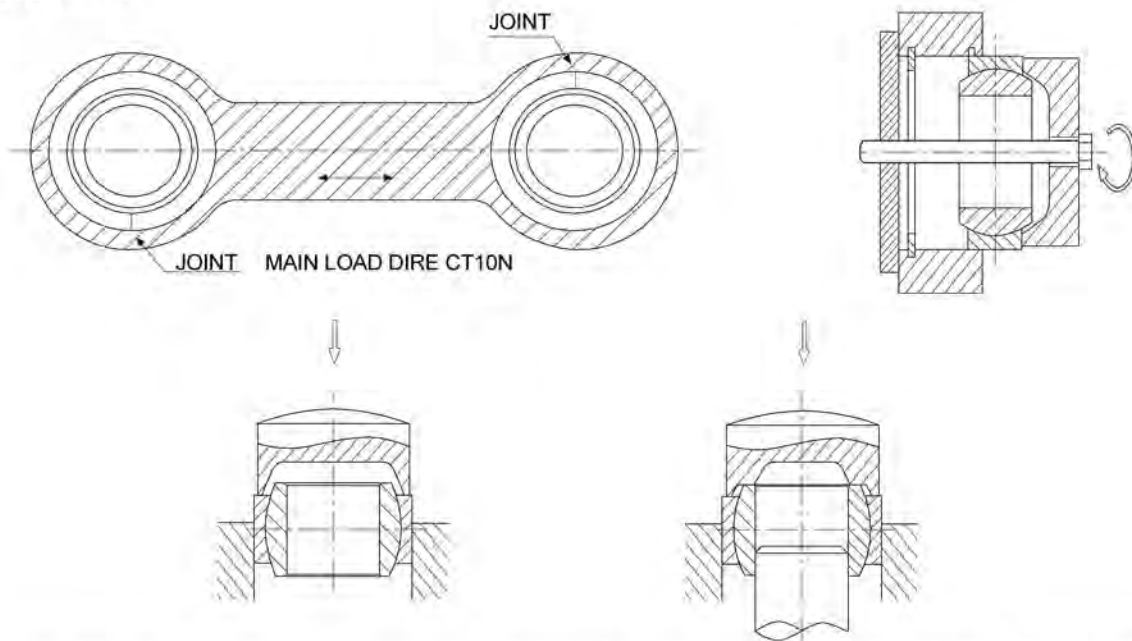

When mounting spherical plain bearings with a fractured or two-part outer ring, it is essential that the joint should be positioned at 90° to the main load direction, otherwise the service life will be shortened, particularly under heavy loads.

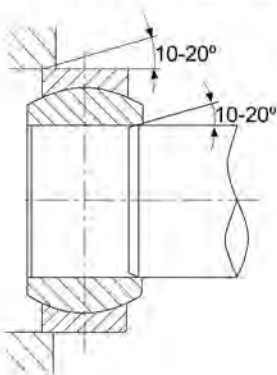

To facilitate mounting, the ends of pins or shafts and the edges of housing bores should have a lead chamfer of 10° to 20°. The bearings can be more easily pushed into position and there is little risk of damage to the mating surfaces being caused by skewing of the bearing.

10. LUBRICATION AND MAINTENANCE

10.1 General instruction

The useful life of all spherical bearings and rod ends with metallic mating materials is greatly dependent on regular lubrication.

A one-off initial grease filling is only adequate if operating loads are very low.

The effectiveness of lubrication is mainly dependent on the load, type of the load (constant, pulsating or alternating), the swivel and sliding speed. To ensure optimum and even distribution of the lubricant, initial and subsequent lubrication should be carried out with the spherical plain bearings or rod ends in an unloaded condition.

Note:

In order to avoid incompatibility of various lubricants that may be used by **LDK** and the customer, spherical bearings and rod ends are supplied only with an anticorrosive coating. For this reason, spherical bearings and rod ends which need maintenance should be given initial lubrication before commissioning or directly after installation. We recommend carrying out initial lubrication after a running-in time of approx 1 hour. Whenever this lubrication is carried out, the bearing must be in an unloaded condition, so that the lubricant can spread without obstruction. Lubrication should continue until the lubricant emerges between the bearing outer ring and the inner ring. For rod ends with a female thread, it is also advisable to fill the space in the shank thread with lubricant up to the threaded connection journal before installation. This reduces the amount of work involved in lubricating with the lubricating nipple.

10.2 Lubrication & maintenance of spherical plain bearings

For spherical plain bearings requiring maintenance which are of the steel-on-steel type, the purpose of the lubrication is primarily to reduce wear, reduce friction and prevent scuffing. Also the grease serves to protect the bearings against corrosion. The frequency of relubrication of the bearing during its operation will appreciably extend the service life.

For steel-on-PTFE fabric spherical plain bearings, there is a transfer of PTFE from fabric to the opposing steel surface of the inner ring. Any lubrication of the sliding contact surfaces would disturb this transfer and shorten bearing life. Therefore, lubrication of these bearings is not advisable.

For steel-on-PTFE composite material spherical plain bearings, as a rule, it must not be lubricated. When operating conditions are such that enhanced sealing and protection against corrosion are required, it is recommended that the bearing or the space surrounding the bearing is filled with lithium base grease.

10.3 Lubrication & maintenance of rod ends

LDK steel-on-steel and steel-on-bronze rod ends have very wear-resistant sliding surfaces and perform well under conditions of lubricant starvation. Rod ends with this sliding contact surface combination require regular relubrication.

LDK maintenance-free rod ends sliding contact surfaces have two groups. Steel-on-PTFE composite and steel-on-PTFE fabric. They have very low friction and can be operated without maintenance. Therefore, lubrication of these bearings is not advisable.

10.4 GREASE FITTING CONFIGURATION

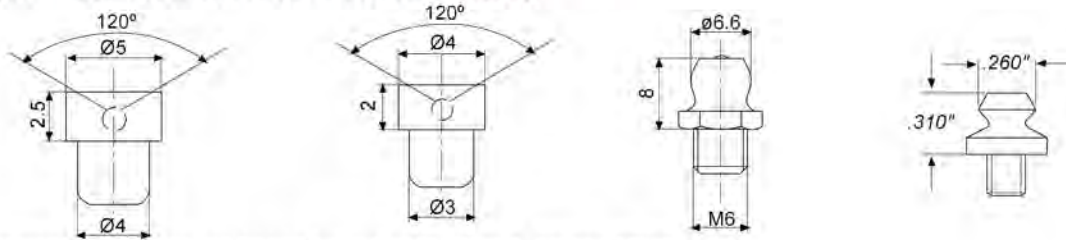

Catalog load ratings are based on rod ends without grease fittings.
For adjusted load ratings with grease fittings consult LDK engineering.

10.5 GREASE FITTING CONFIGURATION

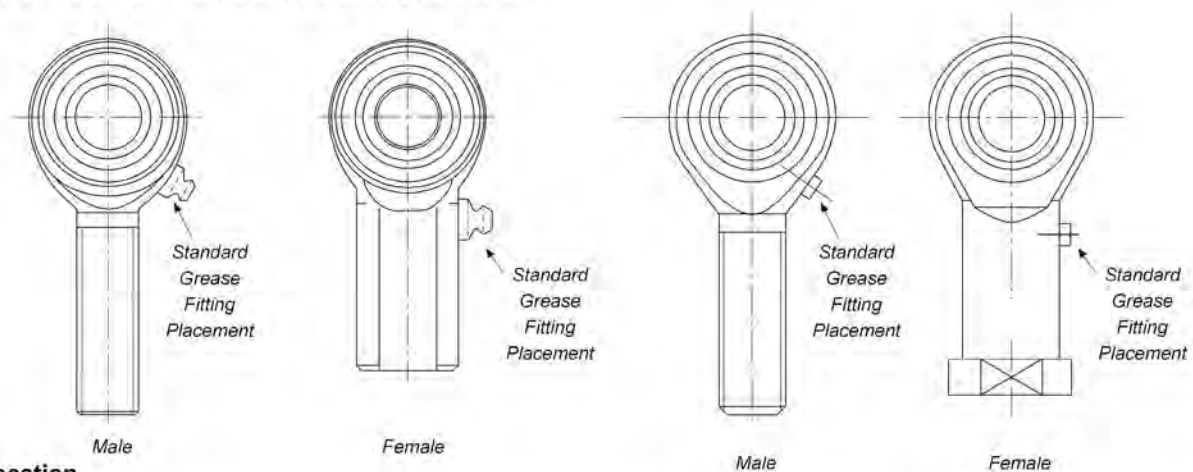

Location

Standard grease fitting locations are illustrated at the right. Note that for a female configuration, once the male threaded component is fully engaged, the grease is forced through the hole at the top of the female shank to facilitate ball lubrication.

Standard Grease Fitting

Order by adding the letter "z" to the completed number. example: CM8Z

11. ACCURACY

The tolerances apply to outer ring without surface treatment and splitting. The outer rings become slightly out of round due to splitting. The roundness of the outer ring is restored once it is fitted in a housing bore produced in accordance with the specifications (Figure1). Measurements taken of the outside diameter of the unfitted bearing cannot be used as the original actual values for the outside diameter.

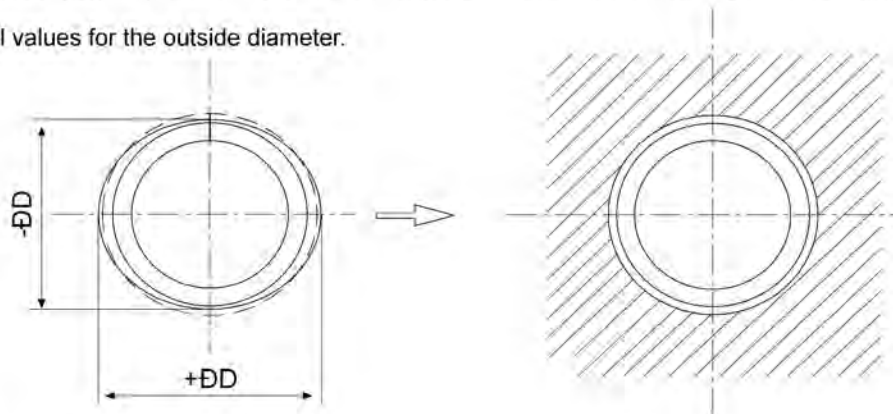

12. STUD CONFIGURATION

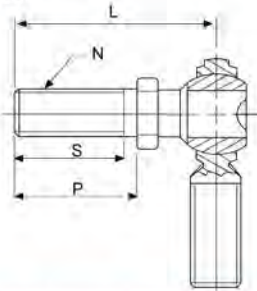

ROD END PART SIZE	L LGTH.	P LGTH.	S LGTH.	N THD.
	+015 -.015	REF.	MIN.	UNF 2A
3	1.016	.500	.437	10-32
4	1.031	.562	.500	1/4-28
5	1.219	.687	.593	5/16-24
6	1.562	.906	.812	3/8-24
7	1.750	1.062	.937	7/16-20
8	2.000	1.125	1.000	1/2-20
10	2.500	1.500	1.375	5/8-18
12	3.000	1.812	1.625	3/4-16

NOTE:

1. AVAILABLE ON ALL SERIES.
2. STUD MATERIAL: LOW CARBON STEEL AND ALLOY STEEL (HEAT TREATED)-ZINC PLATED.
3. STUD MISALIGNMENT APPROX. $\pm 25^\circ$ IN ANY DIRECTION.
4. TO SPECIFY RIGHT HAND STUD, ADD SUFFIX "Y" TO PART NUMBER.
EXAMPLE: CM6Y
5. TO SPECIFY LEFT HAND STUD, ADD SUFFIX "YL" TO PART NUMBER.
EXAMPLE: CM6YX
6. TO SPECIFY HEAT TREATED STUD, ADD SUFFIX "YX" TO PART NUMBER.
EXAMPLE: CM6YX
7. FOR LOAD RANGINGS WITH STUDS, PLEASE CONTACT LDK ENGINEERING DEPARTMENT.

13. WARRANTY & DISCLAIMER

13.1 Warranty

LDK warrants that the products will be free from defects in material and workmanship for one year from date of sale. LDK makes no other warranty of any kind, express or implied. LDK shall have no obligation under the foregoing warranty where the defect is the result of improper or abnormal use, negligence, vehicle accident, improper or incorrect installation or maintenance, nor when the product has been repaired or altered in any way so as (in our judgment) to affect its performance. LDK's liability in the case of defective products subject to the foregoing warranty shall be limited to the repair or replacement, at LDK's option, of the defective products. Except expressly provide herein, LDK shall have no liability (on account negligence or otherwise) for, or in connection with, defects or deficiencies in the products and in no event shall LDK be liable for any incidental, special or consequential damages or commercial loss (including loss revenue or profits) of buyer or any other person, arising out of the use, or inability to use, the goods, or the failure or ineffectiveness of the goods.

13.2 DISCLAIMER

LDK reserves the right to substitute equal or stronger materials at their discretion. LDK reserve the right to change specifications and other information included in this catalog without notice. All information, data and dimension tables in this catalog have been carefully compiled and thoroughly checked. However, no responsibility for errors or omissions can be assumed.

WARNING

Since the manufacturer is unable to determine all applications in which a part may be placed, it's the user's responsibility to determine the suitability of the part of its intended use. This is especially true where safety is a factor. Incorrect application or installation may result in property damage, bodily injury, or death. For technical assistance, please check with us.

PHS..

Ball: Gcr15 Steel, heat treated, HRC58~64;
Precision ground, polished

Body: Carbon steel, Zinc plated,chromate treated

Race: Brass

Sliding contact surfaces: Steel/Brass

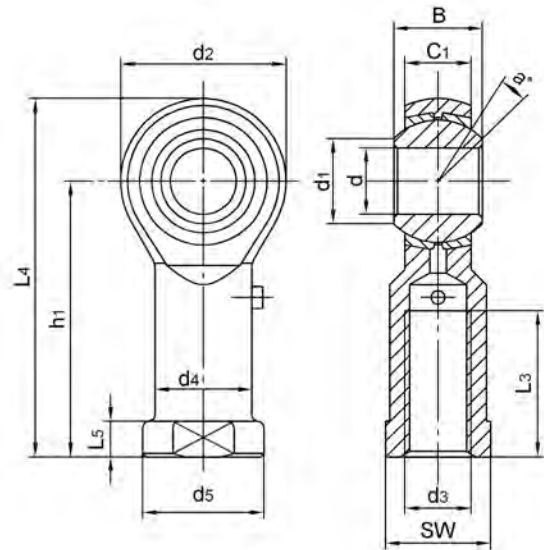

Bearing No.	Dimensions(mm)													Ball dia	a° mis. angle	Load ratings (KN)		weight ≈ Kg
	d _{HT}	B	C ₁	d ₁	d ₂	d ₃ -6H	h ₁	L ₃	(L ₄)	L ₅	d ₄	d ₅	SW			Dynamic	Static	
PHS3	3	6	4.5	5.1	12	M3	21	10	27	3	7	9	7	7.93	14	1.8	4.5	0.006
PHS4	4	7	5.25	6.5	14	M4	24	12	31	4	7.8	9.5	8	9.52	13	2.2	5.6	0.013
PHS5	5	8	6	7.7	16	M5	27	11	35	4	9	11	9	11.11	13	2.5	6.6	0.016
PHS6	6	9	6.75	8.9	18	M6	30	13	39	5	10	13	11	12.7	13	3.2	8.1	0.025
PHS8	8	12	9	10.3	22	M8	36	16	47	5	12.5	16	14	15.87	14	5.4	12.6	0.043
PHS10	10	14	10.5	12.9	26	M10	43	20	56	6.5	15	19	17	19.05	13	7.5	16.6	0.072
PHS10F1						M10x1.25												
PHS12	12	16	12	15.4	30	M12	50	23	65	6.5	17.5	22	19	22.22	13	10	22	0.107
PHS12/F2						M12x1.25												
PHS14	14	19	13.5	16.8	34	M14	57	27	74	8	20	25	22	25.4	16	13	27.8	0.160
PHS14F1						M14x1.5												
PHS15	15	20	14	18.1	36	M14	61	30	79	8	21	26	22	26.98	16	14.5	29	0.186
PHS16	16	21	15	19.3	38	M16	64	32	83	8	22	27	22	28.58	15	16	34.5	0.210
PHS16F1						M16x1.5												
PHS17	17	22	16	20.6	40	M16x1.5	67	34	87	10	24	31	27	30.16	14	18	36	0.259
PHS18	18	23	16.5	21.8	42	M18x1.5	71	35	92	10	25	31	27	31.75	15	19.5	40.8	0.295
PHS20	20	25	18	24.3	46	M20x1.5	77	39	100	10	27.5	34	30	34.92	14	23	46.5	0.380
PHS22	22	28	20	25.8	50	M22x1.5	84	42	109	12	30	37	32	38.1	15	29	52.6	0.490
PHS25	25	31	22	29.5	60	M24x2	94	48	124	12	33.5	42	36	42.86	15	40.5	74.1	0.750
PHS28	28	35	24	32.29	66	M27x2	103	53	136	12	37	46	41	47.63	15	46.1	88.7	0.950
PHS30	30	37	25	34.8	70	M30x2	110	56	145	15	40	50	41	50.8	17	54.3	94.0	1.130

Can supply rod ends with different pitch or accuracy of thread.

For left-hand thread, suffix"L" is added to bearing numbers. eg.: PHS20L M20 x 1.5L-6H:

POS..

Ball: Gcr15 Steel, heat treated, HRC58~64;
Precision ground, polished

Body: Carbon steel, Zinc plated, chromate treated

Race: Brass

Sliding contact surfaces: Steel/Brass

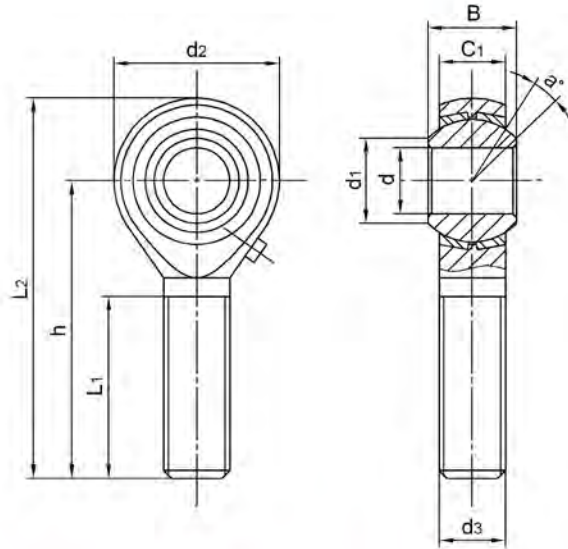

Bearing No.	Dimensions(mm)									Ball dia	a° mis. angle	Load ratings (KN)		weight ≈ Kg
	d _{H7}	B	C ₁	d ₁	d ₂	d ₃ -6g	h	L ₁	L ₂			Dynamic	Static	
POS3	3	6	4.5	5.1	12	M3	26	15	32	7.93	14	1.5	1.8	0.006
POS4	4	7	5.25	6.5	14	M4	30	19	37	9.52	13	2.0	2.9	0.011
POS5	5	8	6	7.7	16	M5	33	20	41	11.11	13	2.5	3.5	0.012
POS6	6	9	6.75	8.9	18	M6	36	22	45	12.7	13	3.2	4.8	0.019
POS8	8	12	9	10.3	22	M8	42	25	53	15.87	14	5.4	8.9	0.032
POS10	10	14	10.5	12.9	26	M10	48	29	61	19.05	13	7.5	12.5	0.054
POS10F1						M10x1.25								
POS12	12	16	12	15.4	30	M12	54	33	69	22.22	13	10	15.8	0.085
POS12/F2						M12x1.25								
POS14	14	19	13.5	16.8	34	M14	60	36	77	25.4	16	13	22.1	0.126
POS14F1						M14x1.5								
POS15	15	20	14	18.1	36	M14	63	38	81	26.98	16	14.5	23.6	0.186
POS16	16	21	15	19.3	38	M16	66	40	85	28.58	15	16	25.9	0.185
POS16F1						M16x1.5								
POS17	17	22	16	20.6	40	M16x1.5	69	42	89	30.16	14	18	28.4	0.259
POS18	18	23	16.5	21.8	42	M18x1.5	72	44	93	31.75	15	19.5	30.8	0.260
POS20	20	25	18	24.3	46	M20x1.5	78	47	101	34.92	14	23	36.2	0.340
POS22	22	28	20	25.8	50	M22x1.5	84	51	109	38.1	15	29	42.6	0.435
POS25	25	31	22	29.5	60	M24x2	94	57	124	42.86	15	40.5	74.1	0.650
POS28	28	35	24	32.29	66	M27x2	103	62	136	47.63	15	46.1	88.7	0.875
POS30	30	37	25	34.8	70	M30x2	110	66	145	50.8	17	54.3	94.0	1.070

Can supply rod ends with different pitch or accuracy of thread.

For left-hand thread, suffix "L" is added to bearing numbers. eg.: POS20L M20 x 1.5L-6g:

CHS..

Ball: Gcr15 Steel, heat treated, HRC58~64;
Precision ground, polished

Body: Carbon steel, Zinc plated, chromate treated

Race: Brass, PTFE composite bonded to I.D of race

Sliding contact surfaces: Steel/PTFE composite

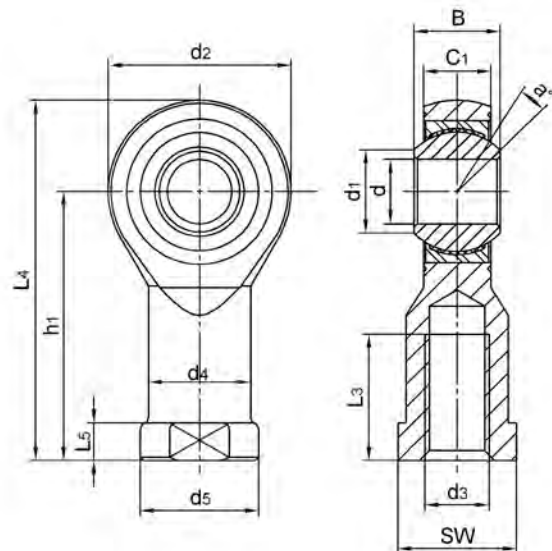

Bearing No.	Dimensions(mm)														Ball dia	a° mis. angle	Load ratings (KN)		weight ≈ Kg
	d _{H7}	B	C ₁	d ₁	d ₂	d _{3-6H}	h ₁	L ₃	(L ₄)	L ₅	d ₄	d ₅	SW	Dynamic			Static		
CHS3	3	6	4.5	5.1	14	M3	21	7	27	3	7	9	7	7.93	14	1.8	4.1	0.006	
CHS4	4	7	5.25	6.5	16	M4	24	8	31	4	7.8	9.5	8	9.52	13	2.8	5.2	0.013	
CHS5	5	8	6	7.7	18	M5	27	10	36	4	9	11	9	11.11	13	3.25	8	0.016	
CHS6	6	9	6.75	8.9	20	M6	30	12	40	5	10	13	11	12.7	13	4.25	8.9	0.022	
CHS8	8	12	9	10.3	24	M8	36	16	48	5	12.5	16	13	15.87	14	7.1	14.1	0.047	
CHS10	10	14	10.5	12.9	28	M10	43	20	57	6.5	15	19	17	19.05	13	9.8	19.3	0.077	
CHS12	12	16	12	15.4	32	M12	50	22	66	6.5	17.5	22	19	22.22	13	13.2	23.5	0.100	
CHS14	14	19	13.5	16.8	36	M14	57	25	75	8	20	25	22	25.4	16	17	28	0.160	
CHS16	16	21	15	19.3	42	M16	64	28	85	8	22	27	22	28.58	15	21.4	32	0.220	
CHS18	18	23	16.5	21.8	46	M18x1.5	71	32	94	10	25	31	27	31.75	15	26	42.5	0.320	
CHS20	20	25	18	24.3	50	M20x1.5	77	33	102	10	27.5	34	30	34.92	14	31	47.5	0.420	
CHS22	22	28	20	25.8	54	M22x1.5	84	37	111	12	30	37	32	38.1	15	42.2	57	0.540	
CHS25	25	31	22	29.5	60	M24x2	94	42	124	12	33.5	42	36	42.86	15	52.7	68	0.730	
CHS28	28	35	24	32.29	66	M27x2	103	44	136	12	37	46	41	47.63	15	58.8	79	0.949	
CHS30	30	37	25	34.8	70	M30x2	110	51	145	15	40	50	41	50.8	17	70.7	88	1.100	

Can supply rod ends with different pitch or accuracy of thread.

For left-hand thread, suffix "L" is added to bearing numbers. eg.: CHS20L M20 x 1.5L-6H:

COS..

Ball: Gcr15 Steel, heat treated, HRC58~64;
Precision ground, polished

Body: Carbon steel, Zinc plated,chromate treated

Race: Brass, PTFE composite bonded to I.D of race

Sliding contact surfaces: Steel/PTFE composite

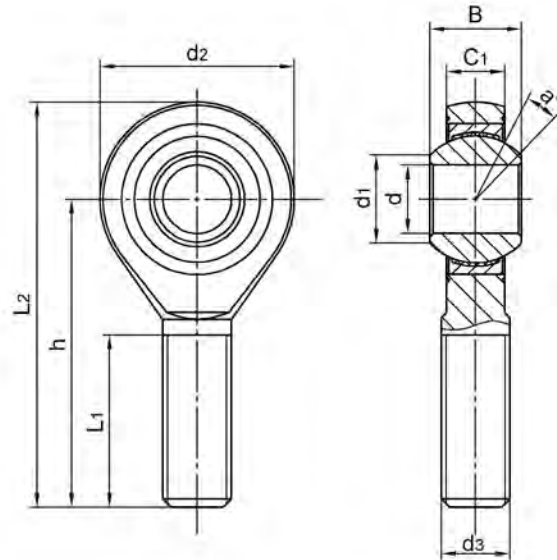

Bearing No.	Dimensions(mm)									Ball dia	a° mis. angle	Load ratings (KN)		weight ≈ Kg
	d _{HT}	B	C ₁	d ₁	d ₂	d _{3-6g}	h	L ₁	L ₂			Dynamic	Static	
COS3	3	6	4.5	5.1	14	M3	26	15	33	7.93	14	1.5	1.8	0.006
COS4	4	7	5.25	6.5	16	M4	30	19	38	9.52	13	2.0	2.9	0.011
COS5	5	8	6	7.7	18	M5	33	19	42	11.11	13	3.25	4.3	0.013
COS6	6	9	6.75	8.9	20	M6	36	21	46	12.7	13	4.25	6	0.020
COS8	8	12	9	10.3	24	M8	42	25	54	15.87	14	7.1	11	0.038
COS10	10	14	10.5	12.9	28	M10	48	28	63	19.05	13	9.8	17.4	0.055
COS12	12	16	12	15.4	32	M12	54	32	71	22.22	13	13.2	23.5	0.085
COS14	14	19	13.5	16.8	36	M14	60	36	79	25.4	16	17	28	0.140
COS16	16	21	15	19.3	42	M16	66	37	87	28.58	15	21.4	32	0.210
COS18	18	23	16.5	21.8	46	M18x1.5	72	41	95	31.75	15	26	42.5	0.280
COS20	20	25	18	24.3	50	M20x1.5	78	45	103	34.92	14	31	47.5	0.380
COS22	22	28	20	25.8	54	M22x1.5	84	48	112	38.1	15	42.2	57	0.480
COS25	25	31	22	29.5	60	M24x2	94	55	124	42.86	15	52.7	68	0.640
COS28	28	35	24	32.29	66	M27x2	103	62	136	47.63	15	58.8	79	0.949
COS30	30	37	25	34.8	70	M30x2	110	66	145	50.8	17	70.7	88	1.100

Can supply rod ends with different pitch or accuracy of thread.

For left-hand thread, suffix"L" is added to bearing numbers. eg.: COS20L M20 x 1.5L-6g:

PHS..EC

Ball: Gcr15 Steel, heat treated, HRC58~64;
Precision ground, polished

Body: Carbon steel, Zinc plated,chromate treated

Race: PTFE composite

Sliding contact surfaces: Steel/PTFE composite

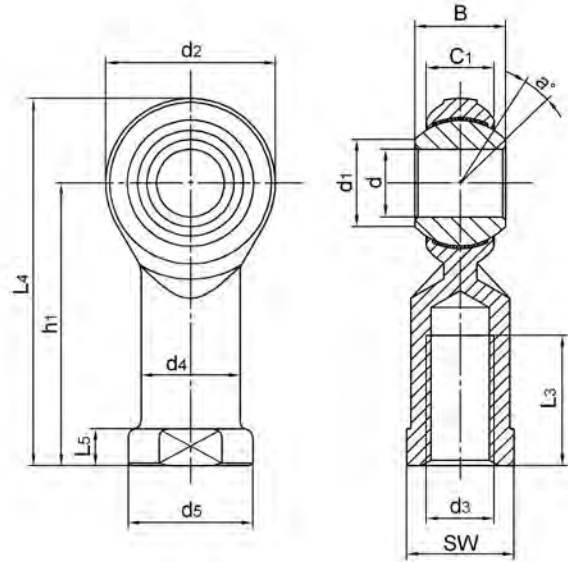

Bearing No.	Dimensions(mm)													Ball dia	a° mis. angle	Load ratings (KN)		weight ≈ Kg
	d _{H7}	B	C ₁ _{max}	d ₁	d ₂	d ₃ -6H	h ₁	L ₃	L ₄	L ₅	d ₄	d ₅	SW			Dynamic	Static	
PHS5EC	5	8	6	7.7	16	M5	27	11	35	4	9	11	9	11.11	13	3.3	6.2	0.016
PHS6EC	6	9	6.75	8.9	18	M6	30	13	39	5	10	13	11	12.7	13	4.7	7.8	0.025
PHS8EC	8	12	9	10.3	22	M8	36	16	47	5	12.5	16	14	15.87	14	7.7	13.2	0.043
PHS10EC	10	14	10.5	12.9	26	M10	43	20	56	6.5	15	19	17	19.05	13	10.4	17.3	0.072
PHS12EC	12	16	12	15.4	30	M12	50	23	65	6.5	17.5	22	19	22.22	13	13.5	22.7	0.107
PHS14EC	14	19	13.5	16.8	34	M14	57	27	74	8	20	25	22	25.4	16	17.2	28.2	0.160
PHS16EC	16	21	15	19.3	38	M16	64	32	83	8	22	27	22	28.58	15	21	35.1	0.210
PHS18EC	18	23	16.5	21.8	42	M18x1.5	71	35	92	10	25	31	27	31.75	15	25	43.2	0.295
PHS20EC	20	25	18	24.3	46	M20x1.5	77	39	100	10	27.5	34	30	34.92	14	29.8	50.3	0.380
PHS22EC	22	28	20	25.8	50	M22x1.5	84	42	109	12	30	37	32	38.1	15	36.2	63.9	0.490

Can supply rod ends with different pitch or accuracy of thread.

For left-hand thread, suffix"L" is added to bearing numbers. eg.: PHS20ECL M20 x 1.5L-6H:

POS..EC

Ball: Gcr15 Steel, heat treated, HRC58~64;
Precision ground, polished

Body: Carbon steel, Zinc plated,chromate treated

Race: PTFE composite

Sliding contact surfaces: Steel/PTFE composite

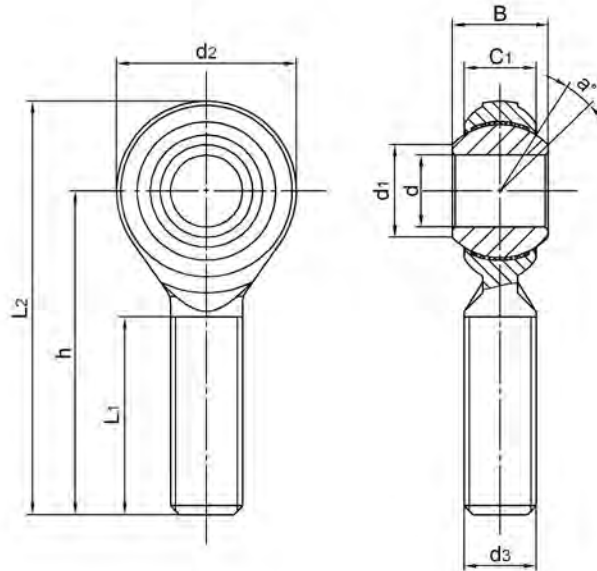

Bearing No.	Dimensions(mm)									Ball dia	a° mis. angle	Load ratings (KN)		weight ≈ Kg
	d _{H7}	B	C1 _{MAX}	d ₁	d ₂	d _{3-6g}	h	L ₁	L ₂			Dynamic	Static	
POS5EC	5	8	6	7.7	16	M5	33	20	41	11.11	13	3.3	4.8	0.012
POS6EC	6	9	6.75	8.9	18	M6	36	22	45	12.7	13	4.7	6.8	0.019
POS8EC	8	12	9	10.3	22	M8	42	25	53	15.87	14	7.7	12.3	0.032
POS10EC	10	14	10.5	12.9	26	M10	48	29	61	19.05	13	10.4	17.3	0.054
POS12EC	12	16	12	15.4	30	M12	54	33	69	22.22	13	13.5	22.7	0.085
POS14EC	14	19	13.5	16.8	34	M14	60	36	77	25.4	16	17.2	28.2	0.126
POS16EC	16	21	15	19.3	38	M16	66	40	85	28.58	15	21	35.1	0.185
POS18EC	18	23	16.5	21.8	42	M18x1.5	72	44	93	31.75	15	25	43.2	0.260
POS20EC	20	25	18	24.3	46	M20x1.5	78	47	101	34.92	14	29.8	50.3	0.340
POS22EC	22	28	20	25.8	50	M22x1.5	84	51	109	38.1	15	36.2	63.9	0.435

Can supply rod ends with different pitch or accuracy of thread.

For left-hand thread, suffix"L" is added to bearing numbers. eg.: POS20ECL M20 x 1.5L-6H:



PHS..HD

Ball: Gcr15 Steel, heat treated, HRC58~64;
Precision ground, polished

Body: Carbon steel, Zinc plated, chromate treated

Race: Brass

Sliding contact surfaces: Steel/Brass

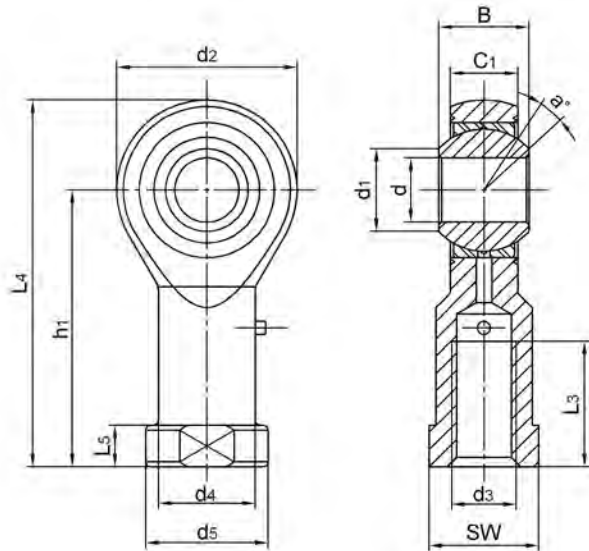

Bearing No.	Dimensions(mm)													Ball dia	a° mis. angle	Load ratings (KN)		weight ≈ Kg
	d _{HT}	B	C ₁	d ₁	d ₂	d _{3-6H}	h ₁	L ₃	(L ₄)	L ₅	d ₄	d ₅	SW			Dynamic	Static	
PHS5HD	5	8	6	7.7	18	M5	27	10	36	4	9	11	9	11.11	13	3.2	8	0.016
PHS6HD	6	9	6.75	8.9	20	M6	30	12	40	5	10	13	11	12.7	13	4.2	8.9	0.022
PHS8HD	8	12	9	10.3	24	M8	36	16	48	5	12.5	16	13	15.87	14	7.1	14.1	0.047
PHS10HD	10	14	10.5	12.9	28	M10	43	20	57	6.5	15	19	17	19.05	13	9.8	19.3	0.077
PHS12HD	12	16	12	15.4	32	M12	50	22	66	6.5	17.5	22	19	22.22	13	13.2	23.5	0.100
PHS14HD	14	19	13.5	16.8	36	M14	57	25	75	8	20	25	22	25.4	16	17	28	0.160
PHS16HD	16	21	15	19.3	42	M16	64	28	85	8	22	27	22	28.58	15	21.4	32	0.220
PHS18HD	18	23	16.5	21.8	46	M18x1.5	71	32	94	10	25	31	27	31.75	15	26	42.5	0.320
PHS20HD	20	25	18	24.3	50	M20x1.5	77	33	102	10	27.5	34	30	34.92	14	31	47.5	0.420
PHS22HD	22	28	20	25.8	54	M22x1.5	84	37	111	12	30	37	32	38.1	15	42.2	57	0.540
PHS25HD	25	31	22	29.5	60	M24x2	94	42	124	12	33.5	42	36	42.86	15	52.7	68	0.730
PHS28HD	28	35	24	32.29	66	M27x2	103	44	136	12	37	46	41	47.63	15	58.8	79	0.949
PHS30HD	30	37	25	34.8	70	M30x2	110	51	145	15	40	50	41	50.8	17	70.7	88	1.100

Can supply rod ends with different pitch or accuracy of thread.

For left-hand thread, suffix "L" is added to bearing numbers. eg.: PHS20HDL M20 x 1.5L-6H:

POS..HD

Ball: Gcr15 Steel, heat treated, HRC58~64;
Precision ground, polished

Body: Carbon steel, Zinc plated,chromate treated

Race: Brass

Sliding contact surfaces: Steel/Brass

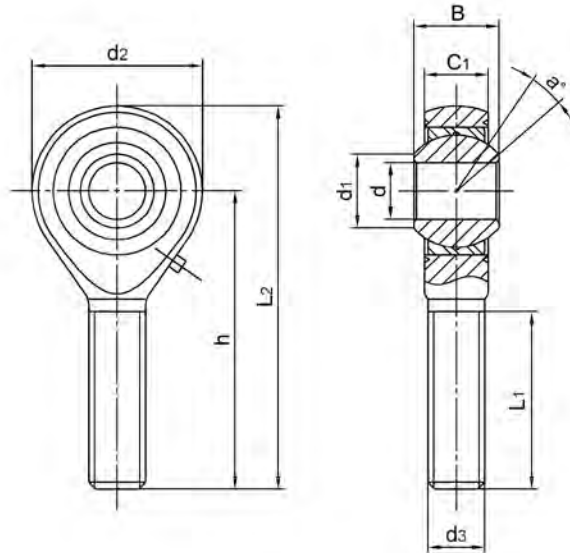

Bearing No.	Dimensions(mm)									Ball dia	a° mis. angle	Load ratings (KN)		weight ≈ Kg
	d _{H7}	B	C ₁	d ₁	d ₂	d ₃ -6g	h	L ₁	L ₂			Dynamic	Static	
POS5HD	5	8	6	7.7	18	M5	33	19	42	11.11	13	3.2	4.3	0.013
POS6HD	6	9	6.75	8.9	20	M6	36	21	46	12.7	13	4.2	6	0.020
POS8HD	8	12	9	10.3	24	M8	42	25	54	15.87	14	7.1	11	0.038
POS10HD	10	14	10.5	12.9	28	M10	48	28	63	19.05	13	9.8	17.4	0.055
POS12HD	12	16	12	15.4	32	M12	54	32	71	22.22	13	13.2	23.5	0.085
POS14HD	14	19	13.5	16.8	36	M14	60	36	79	25.4	16	17	28	0.140
POS16HD	16	21	15	19.3	42	M16	66	37	87	28.58	15	21.4	32	0.210
POS18HD	18	23	16.5	21.8	46	M18x1.5	72	41	95	31.75	15	26	42.5	0.280
POS20HD	20	25	18	24.3	50	M20x1.5	78	45	103	34.925	14	31	47.5	0.380
POS22HD	22	28	20	25.8	54	M22x1.5	84	48	112	38.1	15	42.2	57	0.480
POS25HD	25	31	22	29.5	60	M24x2	94	55	124	42.86	15	52.7	68	0.640
POS28HD	28	35	24	32.29	66	M27x2	103	62	136	47.63	15	58.8	79	0.949
POS30HD	30	37	25	34.8	70	M30x2	110	66	145	50.8	17	70.7	88	1.100

Can supply rod ends with different pitch or accuracy of thread.

For left-hand thread, suffix "L" is added to bearing numbers. eg.: POS20HDL M20 x 1.5L-6g:

SPHS..

Ball: 440C stainless steel, heat treated HRC56min
Precision ground polished

Body: SUS304 Stainless steel

Race: Brass

Sliding contact surfaces: Steel/Brass

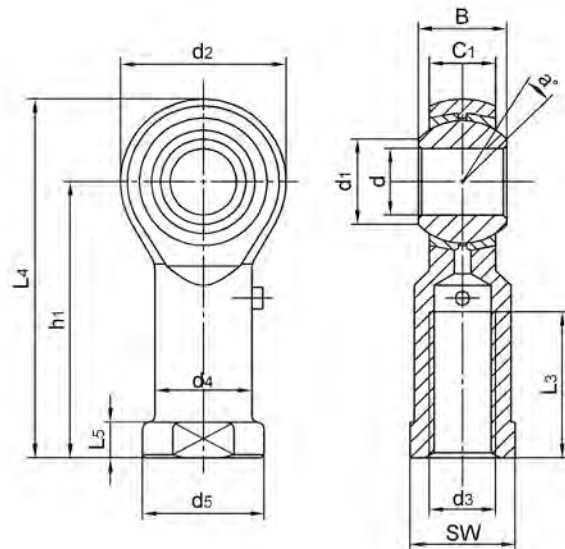

Bearing No.	Dimensions(mm)													Ball dia	a° mis. angle	Load ratings (KN)		weight ≈ Kg
	d _{H7}	B	C ₁	d ₁	d ₂	d _{3-6H}	h ₁	L ₃	(L ₄)	L ₅	d ₄	d ₅	SW			Dynamic	Static	
SPHS5	5	8	6	7.7	16	M5	27	11	35	4	9	11	9	11.11	13	2.5	6.6	0.016
SPHS6	6	9	6.75	8.9	18	M6	30	13	39	5	10	13	11	12.7	13	3.2	8.1	0.025
SPHS8	8	12	9	10.3	22	M8	36	16	47	5	12.5	16	14	15.87	14	5.4	12.6	0.043
SPHS10	10	14	10.5	12.9	26	M10	43	20	56	6.5	15	19	17	19.05	13	7.5	16.6	0.072
SPHS12	12	16	12	15.4	30	M12	50	23	65	6.5	17.5	22	19	22.22	13	10	22	0.107
SPHS14	14	19	13.5	16.8	34	M14	57	27	74	8	20	25	22	25.4	16	13	27.8	0.160
SPHS15	15	20	14	18.1	36	M14	61	30	79	8	21	26	22	26.98	16	14.5	29	0.186
SPHS16	16	21	15	19.3	38	M16	64	32	83	8	22	27	22	28.58	15	16	34.5	0.210
SPHS17	17	22	16	20.6	40	M16x1.5	67	34	87	10	24	31	27	30.16	14	18	36	0.259
SPHS18	18	23	16.5	21.8	42	M18x1.5	71	35	92	10	25	31	27	31.75	15	19.5	40.8	0.295
SPHS20	20	25	18	24.3	46	M20x1.5	77	39	100	10	27.5	34	30	34.92	14	23	46.5	0.380
SPHS22	22	28	20	25.8	50	M22x1.5	84	42	109	12	30	37	32	38.1	15	29	52.6	0.490
SPHS25	25	31	22	29.5	60	M24x2	94	48	124	12	33.5	42	36	42.86	15	40.5	74.1	0.750
SPHS28	28	35	24	32.29	66	M27x2	103	53	136	12	37	46	41	47.63	15	46.1	88.7	0.950
SPHS30	30	37	25	34.8	70	M30x2	110	56	145	15	40	50	41	50.8	17	54.3	94.0	1.130

Can supply rod ends with different pitch or accuracy of thread.

For left-hand thread, suffix "L" is added to bearing numbers. eg.: SPHS20L M20 x 1.5L-6H:

SPOS..

Ball: 440C stainless steel, heat treated HRC56min
Precision ground polished

Body: SUS304 Stainless steel

Race: Brass

Sliding contact surfaces: Steel/Brass

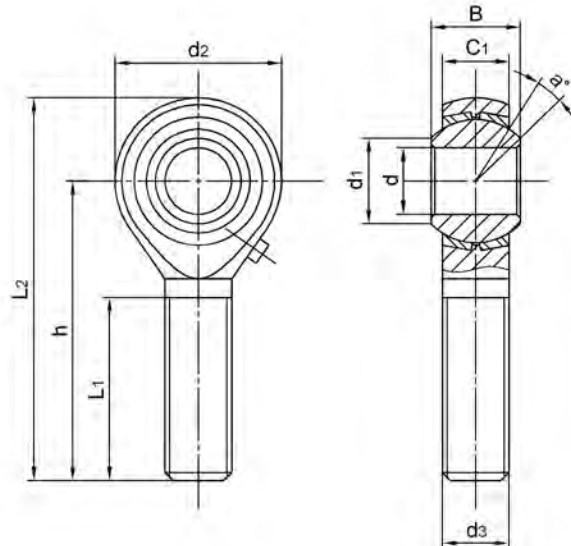

Bearing No.	Dimensions(mm)									Ball dia	a° mis. angle	Load ratings (KN)		weight ≈ Kg
	d _{HT}	B	C ₁	d ₁	d ₂	d _{3-6g}	h	L ₁	L ₂			Dynamic	Static	
SPOS5	5	8	6	7.7	16	M5	33	20	41	11.11	13	2.5	3.5	0.012
SPOS6	6	9	6.75	8.9	18	M6	36	22	45	12.7	13	3.2	4.8	0.019
SPOS8	8	12	9	10.3	22	M8	42	25	53	15.87	14	5.4	8.9	0.032
SPOS10	10	14	10.5	12.9	26	M10	48	29	61	19.05	13	7.5	12.5	0.054
SPOS12	12	16	12	15.4	30	M12	54	33	69	22.22	13	10	15.8	0.085
SPOS14	14	19	13.5	16.8	34	M14	60	36	77	25.4	16	13	22.1	0.126
SPOS15	15	20	14	18.1	36	M14	63	38	81	26.98	16	14.5	23.6	0.186
SPOS16	16	21	15	19.3	38	M16	66	40	85	28.58	15	16	25.9	0.185
SPOS17	17	22	16	20.6	40	M16x1.5	69	42	89	30.16	14	18	28.4	0.259
SPOS18	18	23	16.5	21.8	42	M18x1.5	72	44	93	31.75	15	19.5	30.8	0.260
SPOS20	20	25	18	24.3	46	M20x1.5	78	47	101	34.925	14	23	36.2	0.340
SPOS22	22	28	20	25.8	50	M22x1.5	84	51	109	38.1	15	29	42.6	0.435
SPOS25	25	31	22	29.5	60	M24x2	94	57	124	42.86	15	40.5	74.4	0.650
SPOS28	28	35	24	32.29	66	M27x2	103	62	136	47.63	15	46.1	88.7	0.875
SPOS30	30	37	25	34.8	70	M30x2	110	66	145	50.8	17	54.3	94.0	1.070

Can supply rod ends with different pitch or accuracy of thread.

For left-hand thread, suffix "L" is added to bearing numbers. eg.: SPOS20L M20 x 1.5L-6g:

SCHS..

Ball: 440C Stainless steel, heat treated, HRC 56 min
Precision ground, polished.

Body: 304 Stainless steel

Race: Brass or Stainless steel

PTFE composite bonded to I.D of race

Sliding contact surfaces: Steel/PTFE composite

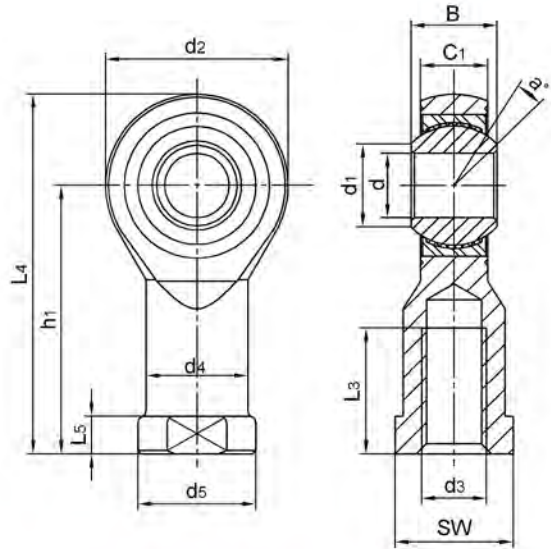

Bearing No.	Dimensions(mm)													Ball dia	a° mis. angle	Load ratings (KN)		weight ≈ Kg
	d _{HT}	B	C ₁	d ₁	d ₂	d _{3-6H}	h ₁	L ₃	L ₄	L ₅	d ₄	d ₅	SW			Dynamic	Static	
SCHS5	5	8	6	7.7	18	M5	27	10	36	4	9	11	9	11.11	13	3.2	8	0.016
SCHS6	6	9	6.75	8.9	20	M6	30	13	40	5	10	13	11	12.7	13	4.2	8.9	0.022
SCHS8	8	12	9	10.3	24	M8	36	16	48	5	12.5	16	13	15.87	14	7.1	14.1	0.047
SCHS10	10	14	10.5	12.9	28	M10	43	20	57	6.5	15	19	17	19.05	13	9.8	19.3	0.077
SCHS12	12	16	12	15.4	32	M12	50	22	66	6.5	17.5	22	19	22.22	13	13.2	23.5	0.100
SCHS14	14	19	13.5	16.8	36	M14	57	25	75	8	20	25	22	25.4	16	17	28	0.160
SCHS16	16	21	15	19.3	42	M16	64	28	85	8	22	27	22	28.58	15	21.4	32	0.220
SCHS18	18	23	16.5	21.8	46	M18x1.5	71	32	94	10	25	31	27	31.75	15	26	42.5	0.320
SCHS20	20	25	18	24.3	50	M20x1.5	77	33	102	10	27.5	34	30	34.92	14	31	47.5	0.420
SCHS22	22	28	20	25.8	54	M22x1.5	84	37	111	12	30	37	32	38.1	15	42.2	57	0.540
SCHS25	25	31	22	29.5	60	M24x2	94	42	124	12	33.5	42	36	42.86	15	52.7	68	0.730
SCHS28	28	35	24	32.29	66	M27x2	103	44	136	12	37	46	41	47.63	15	58.8	79	0.949
SCHS30	30	37	25	34.8	70	M30x2	110	51	145	15	40	50	41	50.8	17	70.7	88	1.100

Can supply rod ends with different pitch or accuracy of thread.

For left-hand thread, suffix "L" is added to bearing numbers. eg.: SCHS20L M20 x 1.5L-6H:

SCOS..

Ball: 440C Stainless steel, heat treated, HRC 56min

Precision ground polished

Body: 304 Stainless steel

Race: Brass or Stainless steel,

PTFE composite bonded to I.D of race

Sliding contact surfaces: Steel/PTFE composite.

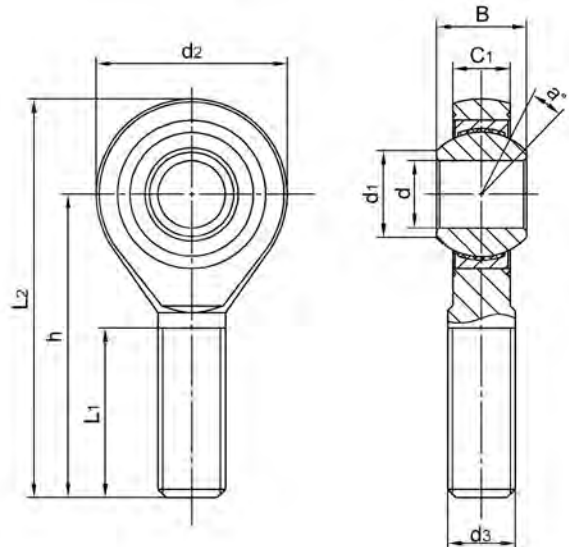

Bearing No.	Dimensions(mm)									Ball dia	a° mis. angle	Load ratings (KN)		weight ≈ Kg
	d _{H7}	B	C ₁	d ₁	d ₂	d _{3-6g}	h	L ₁	L ₂			Dynamic	Static	
SCOS5	5	8	6	7.7	18	M5	33	19	42	11.11	13	3.2	4.3	0.013
SCOS6	6	9	6.75	8.9	20	M6	36	21	46	12.7	13	4.2	6	0.020
SCOS8	8	12	9	10.3	24	M8	42	25	54	15.87	14	7.1	11	0.038
SCOS10	10	14	10.5	12.9	28	M10	48	28	63	19.05	13	9.8	17.4	0.055
SCOS12	12	16	12	15.4	32	M12	54	32	71	22.22	13	13.2	23.5	0.085
SCOS14	14	19	13.5	16.8	36	M14	60	36	79	25.4	16	17	28	0.140
SCOS16	16	21	15	19.3	42	M16	66	37	87	28.58	15	21.4	32	0.210
SCOS18	18	23	16.5	21.8	46	M18x1.5	72	41	95	31.75	15	26	42.5	0.280
SCOS20	20	25	18	24.3	50	M20x1.5	78	45	103	34.92	14	31	47.5	0.380
SCOS22	22	28	20	25.8	54	M22x1.5	84	48	112	38.1	15	42.2	57	0.480
SCOS25	25	31	22	29.5	60	M24x2	94	55	124	42.86	15	52.7	68	0.640
SCOS28	28	35	25	32.29	66	M27x2	103	62	136	47.63	15	58.8	79	0.949
SCOS30	30	37	25	34.8	70	M30x2	110	66	145	50.8	17	70.7	88	1.100

Can supply rod ends with different pitch or accuracy of thread.

For left-hand thread, suffix "L" is added to bearing numbers. eg.: SCOS20L M20 x 1.5L-6g;

SPHS..EC

Ball: 440C Stainless steel, heat treated, HRC 56min
Precision ground, polished

Body: 304 Stainless steel

Race: PTFE composite

Sliding contact surfaces: Steel/PTFE composite

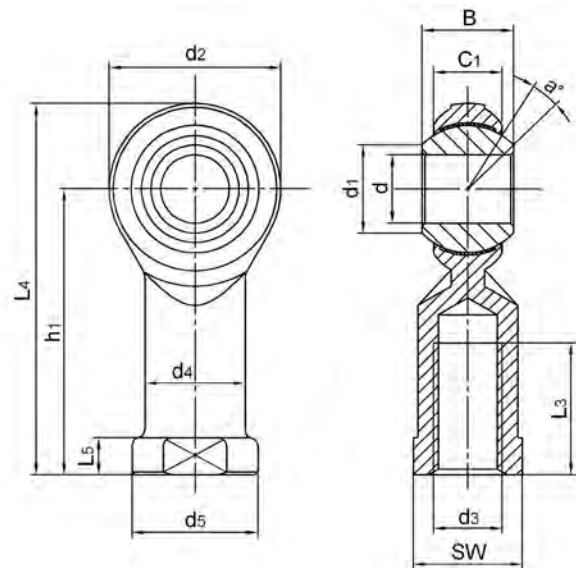

Bearing No.	Dimensions(mm)													Ball dia	a° mis. angle	Load ratings (KN)		weight ≈ Kg
	d _{H7}	B	C _{1max}	d ₁	d ₂	d _{3-6H}	h ₁	L ₃	L ₄	L ₅	d ₄	d ₅	SW			Dynamic	Static	
SPHS5EC	5	8	6	7.7	16	M5	27	11	35	4	9	11	9	11.11	13	3.3	6.2	0.016
SPHS6EC	6	9	6.75	8.9	18	M6	30	13	39	5	10	13	11	12.7	13	4.7	7.8	0.025
SPHS8EC	8	12	9	10.3	22	M8	36	16	47	5	12.5	16	14	15.87	14	7.7	13.2	0.043
SPHS10EC	10	14	10.5	12.9	26	M10	43	20	56	6.5	15	19	17	19.05	13	10.4	17.3	0.072
SPHS12EC	12	16	12	15.4	30	M12	50	23	65	6.5	17.5	22	19	22.22	13	13.5	22.7	0.107
SPHS14EC	14	19	13.5	16.8	34	M14	57	27	74	8	20	25	22	25.4	16	17.2	28.2	0.160
SPHS16EC	16	21	15	19.3	38	M16	64	32	83	8	22	27	22	28.58	15	21	35.1	0.210
SPHS18EC	18	23	16.5	21.8	42	M18x1.5	71	35	92	10	25	31	27	31.75	15	25	43.2	0.295
SPHS20EC	20	25	18	24.3	46	M20x1.5	77	39	100	10	27.5	34	30	34.92	14	29.8	50.3	0.380

Can supply rod ends with different pitch or accuracy of thread.

For left-hand thread, suffix "L" is added to bearing numbers. eg.: SPHS20ECL M20 x 1.5L-6H:



SPOS..EC

Ball: 440C Stainless steel, heat treated, HRC 56min
Precision ground polished

Body: 304 Stainless steel.

Race: PTFE composite

Sliding contact surfaces: Steel/PTFE composite.

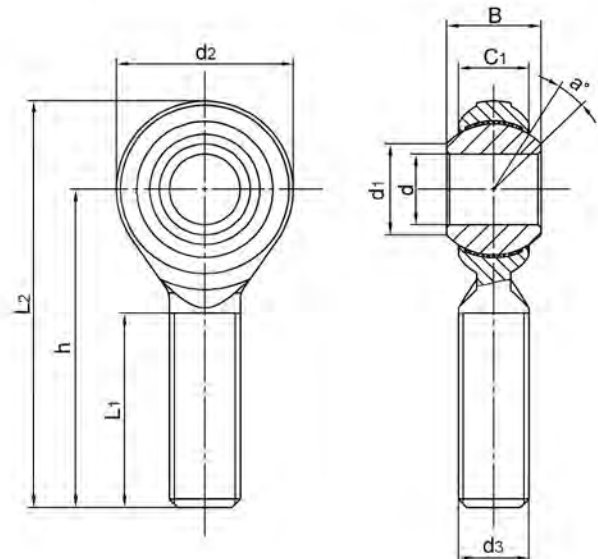

Bearing No.	Dimensions(mm)									Ball dia	a° mis. angle	Load ratings (KN)		weight ≈ Kg
	d _{H7}	B	C1 _{max}	d1	d2	d3-6g	h	L1	L2			Dynamic	Static	
SPOS5EC	5	8	6	7.7	16	M5	33	20	41	11.11	13	3.3	4.8	0.012
SPOS6EC	6	9	6.75	8.9	18	M6	36	22	45	12.7	13	4.7	6.8	0.019
SPOS8EC	8	12	9	10.3	22	M8	42	25	53	15.87	14	7.7	12.3	0.032
SPOS10EC	10	14	10.5	12.9	26	M10	48	29	61	19.05	13	10.4	17.3	0.054
SPOS12EC	12	16	12	15.4	30	M12	54	33	69	22.22	13	13.5	22.7	0.085
SPOS14EC	14	19	13.5	16.8	34	M14	60	36	77	25.4	16	17.2	28.2	0.126
SPOS16EC	16	21	15	19.3	38	M16	66	40	85	28.58	15	21	35.1	0.185
SPOS18EC	18	23	16.5	21.8	42	M18x1.5	72	44	93	31.75	15	25	43.2	0.260
SPOS20EC	20	25	18	24.3	46	M20x1.5	78	47	101	34.92	14	29.8	50.3	0.340

Can supply rod ends with different pitch or accuracy of thread.

For left-hand thread, suffix "L" is added to bearing numbers. eg.: SPOS20ECL M20 x 1.5L-6g:

NPHS..

Ball: Gcr15 steel, heat treated, HRC 58 ~64;
Precision ground, polished.

Body: Carbon steel, zinc plated, chromate treated

Race: Nylon polymer

Sliding contact surfaces: Steel/Nylon

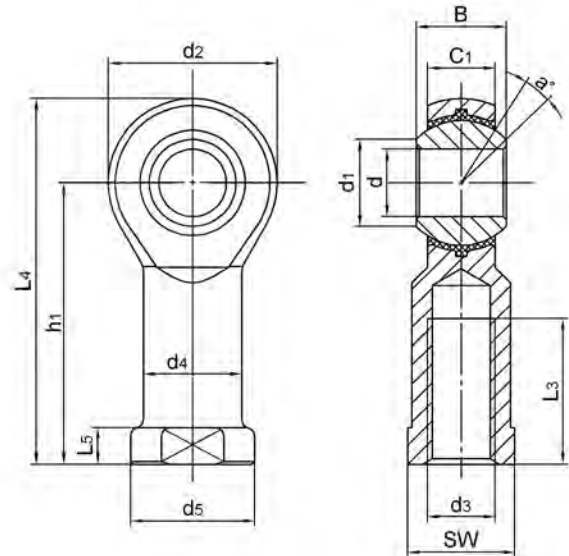

Bearing No.	Dimensions(mm)													Ball dia	a° mis. angle	Load ratings (KN)		weight ≈ Kg
	d _{HT}	B	C ₁	d ₁	d ₂	d ₃ -6H	h ₁	L ₃	L ₄	L ₅	d ₄	d ₅	SW			Dynamic	Static	
NPHS5	5	8	6	7.7	16	M5	27	13	35	4	9	11	9	11.11	13	2.5	6.6	0.016
NPHS6	6	9	6.75	8.9	18	M6	30	13	39	5	10	13	11	12.7	13	3.2	8.1	0.025
NPHS8	8	12	9	10.3	22	M8	36	17	47	5	12.5	16	14	15.87	14	5.4	12.6	0.043
NPHS10	10	14	10.5	12.9	26	M10	43	21	56	6.5	15	19	17	19.05	13	7.5	16.6	0.072
NPHS12	12	16	12	15.4	30	M12	50	24	65	6.5	17.5	22	19	22.22	13	10	22	0.107
NPHS14	14	19	13.5	16.8	34	M14	57	27	74	8	20	25	22	25.4	16	13	27.8	0.160
NPHS16	16	21	15	19.3	38	M16	64	33	83	8	22	27	22	28.58	15	16	34.5	0.210
NPHS18	18	23	16.5	21.8	42	M18x1.5	71	36	92	10	25	31	27	31.75	15	19.5	40.8	0.295
NPHS20	20	25	18	24.3	46	M20x1.5	77	40	100	10	27.5	34	30	34.92	14	23	46.5	0.380
NPHS22	22	28	20	25.8	50	M22x1.5	84	43	109	12	30	37	32	38.1	15	29	52.6	0.490
NPHS25	25	31	22	29.5	60	M24x2	94	48	124	12	33.5	42	36	42.86	15	40.5	74.1	0.750
NPHS28	28	35	24	32.29	66	M27x2	103	53	136	12	37	46	41	47.63	15	46.1	88.7	0.950
NPHS30	30	37	25	34.8	70	M30x2	110	56	145	15	40	50	41	50.8	17	54.3	94	1.130

Can supply rod ends with different pitch or accuracy of thread.

For left-hand thread, suffix "L" is added to bearing numbers. eg.: NPHS20L M20 x 1.5L-6H:

SI..E & SI..ES

Body: Carbon steel Zinc plated, chromate treated

SI..E: Mounted with GE..E type of radial spherical plain bearings.

SI..ES: Mounted with GE..ES type of radial spherical plain bearings.

Sliding contact surfaces: Steel/Steel

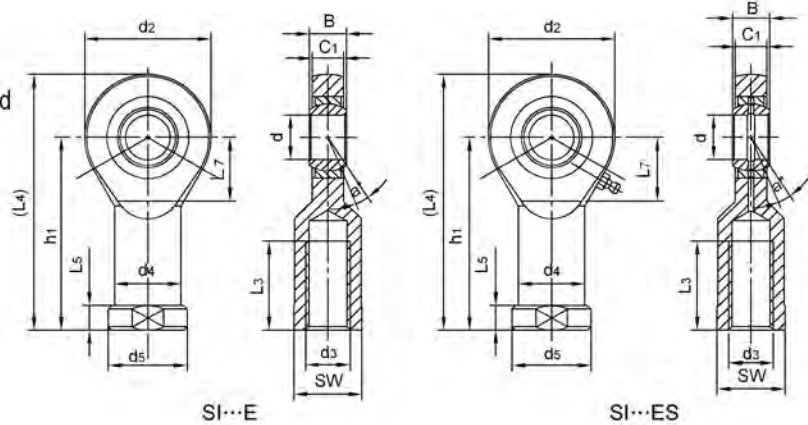

Bearing No.	Dimensions(mm)													Ball dia	a° mis. angle	Load ratings (KN)		Weight ≈ kg
	d	B	C1	d2	d3-6H	h1	L3	L4	L5	L7	d4	d5	W			Dynamic	Static	
SI5E ¹⁾	5	6	4.5	21	M5	30	11	40.5	5	11.5	11	13	11	10	13	3.4	8.1	0.021
SI6E ¹⁾	6	6	4.5	21	M6	30	11	40.5	5	11.5	11	13	11	10	13	3.4	8.1	0.021
SI8E ¹⁾	8	8	6.5	24	M8	36	15	48	5	13	13	16	13	13	15	5.5	12.9	0.039
SI10E ¹⁾	10	9	7.5	29	M10	43	20	57.5	6.5	15	16	19	16	16	12	8.1	17.6	0.061
SI12E ¹⁾	12	10	8.5	34	M12	50	22	67	7	18	18	22	19	18	10	10	24.5	0.096
SI15ES	15	12	10.5	40	M14	61	30	81	8	21	21	26	21	22	8	16	36	0.162
SI17ES	17	14	11.5	46	M16	67	32	90	10	23	25	29	27	25	10	21	45	0.233
SI20ES	20	16	13.5	53	M20x1.5	77	38	103.5	10	25.5	28	34	30	29	9	30	60	0.324
SI25ES	25	20	18	64	M24x2	94	45	126	12	33	35	42	36	35.5	7	48	83	0.625
SI30ES	30	22	20	73	M30x2	110	54	146.5	15	37.5	42	50	46	40.7	6	62	110	0.976
SI35ES	35	25	22	82	M36x3	125	60	166	15	40	48	58	55	47	6	79	146	1.52
SI40ES	40	28	24	92	M39x3	142	65	188	18	47	52	65	60	53	7	99	180	2.06
SI45ES	45	32	28	102	M42x3	145	65	196	20	52	58	70	65	60	7	127	240	2.72
SI50ES	50	35	31	112	M45x3	160	68	216	20	57	62	75	70	66	6	156	290	3.57
SI60ES	60	44	39	135	M52x3	175	70	242.5	20	68.5	70	88	80	80	6	245	450	5.63
SI70ES	70	49	43	160	M56x4	200	80	280	20	81	80	98	85	92	6	313	610	8.33
SI80ES	80	55	48	180	M64x4	230	85	320	25	91	95	110	95	105	6	400	750	13.04

¹⁾Can not be relubricated.

Can supply rod ends with different pitch or accuracy of thread.

For left-hand thread, suffix'L' is added to bearing numbers. eg.: SIL20ES M20 x 1.5L-6H:

SA..E & SA..ES

Body: carbon steel Zinc plated, chromate treated

SA..E: Mounted with GE..E type of radial spherical plain bearings.

SA..ES: Mounted with GE..ES type of radial spherical plain bearings.

Sliding contact surfaces: Steel/Steel

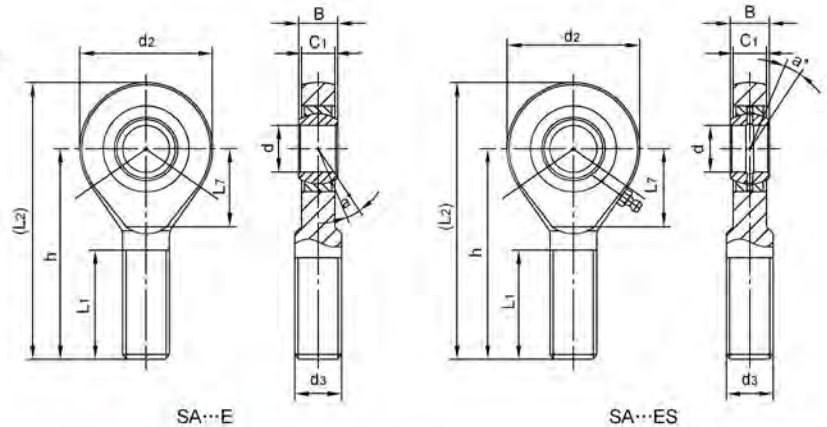

Bearing No.	Dimensions(mm)									Ball dia	a° mis. angle	Load ratings (KN)		Weight ≈ kg
	d	B	C ₁	d ₂	d ₃ -6g	h	L ₁	L ₂	L ₇			Dynamic	Static	
SA5E ¹⁾	5	6	4.5	21	M5	36	16	46.5	12	10	13	3.4	4.6	0.017
SA6E ¹⁾	6	6	4.5	21	M6	36	16	46.5	12	10	13	3.4	6.9	0.017
SA8E ¹⁾	8	8	6.5	24	M8	42	21	54	13	13	15	5.5	12.9	0.029
SA10E ¹⁾	10	9	7.5	29	M10	48	26	62.5	16	16	12	8.1	17.6	0.044
SA12E ¹⁾	12	10	8.5	34	M12	54	28	71	18	18	10	10	24.5	0.066
SA15ES	15	12	10.5	40	M14	63	34	83	22	22	8	16	36	0.121
SA17ES	17	14	11.5	46	M16	69	36	92	24	25	10	21	45	0.172
SA20ES	20	16	13.5	53	M20x1.5	78	43	104.5	27	29	9	30	60	0.283
SA25ES	25	20	18	64	M24x2	94	53	126	33	35.5	7	48	83	0.504
SA30ES	30	22	20	73	M30x2	110	65	146.5	37.5	40.7	6	62	110	0.835
SA35ES	35	25	22	82	M36x3	140	82	181	41	47	6	79	146	1.41
SA40ES	40	28	24	92	M39x3	150	86	196	47	53	7	99	180	1.86
SA45ES	45	32	28	102	M42x3	163	92	214	52	60	7	127	240	2.57
SA50ES	50	35	31	112	M45x3	185	104	241	60	66	6	156	290	3.58
SA60ES	60	44	39	135	M52x3	210	115	277.5	75.5	80	6	245	450	5.73
SA70ES	70	49	43	160	M56x4	235	125	315	95	92	6	313	610	7.94
SA80ES	80	55	48	180	M64x4	270	140	360	105.5	105	6	400	750	12.06

¹⁾Can not be relubricated.

Can supply rod ends with different pitch or accuracy of thread.

For left-hand thread, suffix"L" is added to bearing numbers. eg.: SAL20ES M20 x 1.5L-6g:

SI..C & SI..ET-2RS

Body: Carbon steel Zinc plated, chromate treated

SI..C: Mounted with GE..C type of radial spherical plain bearings.

SI..ET-2RS: Mounted with GE..ET-2RS type of radial spherical plain bearings.

Sliding contact surfaces: SI..C Steel/PTFE composite
SI..ET-2RS Steel/PTFE fabric

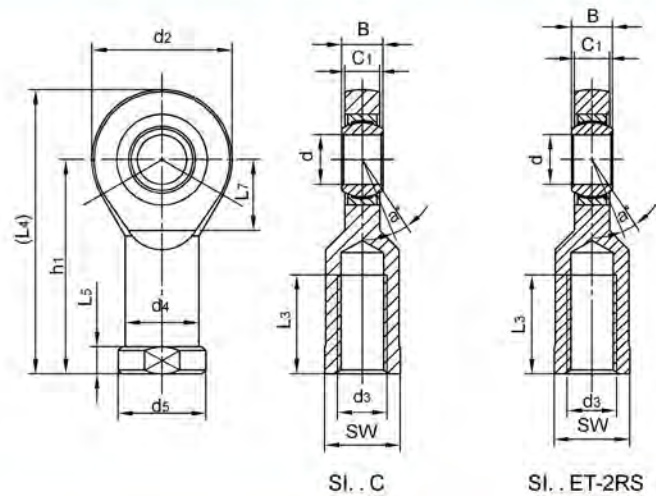

SI..C

SI..ET-2RS

Bearing No.	Dimensions(mm)													Ball dia	a° mis. angle	Load ratings (KN)		Weight ≈ kg
	d	B	C ₁	d ₂	d ₃ -6H	h ₁	L ₃	L ₄	L ₅	L ₇	d ₄	d ₅	W			Dynamic	Static	
SI5C	5	6	4.5	21	M5	30	11	40.5	5	11.5	11	13	11	10	13	3.6	8.1	0.021
SI6C	6	6	4.5	21	M6	30	11	40.5	5	11.5	11	13	11	10	13	3.6	8.1	0.021
SI8C	8	8	6.5	24	M8	36	15	48	5	13	13	16	13	13	15	5.8	12.9	0.039
SI10C	10	9	7.5	29	M10	43	20	57.5	6.5	15	16	19	16	16	12	8.6	17.6	0.061
SI12C	12	10	8.5	34	M12	50	22	67	7	18	18	22	19	18	10	11	24.5	0.096
SI15C SI15ET-2RS	15	12	10.5	40	M14	61	30	81	8	21	21	26	21	22	8	18	36	0.162
SI17C SI17ET-2RS	17	14	11.5	46	M16	67	32	90	10	23	25	29	27	25	10	22	45	0.233
SI20C SI20ET-2RS	20	16	13.5	53	M20x1.5	77	38	103.5	10	25.5	28	34	30	29	9	31	60	0.324
SI25C SI25ET-2RS	25	20	18	64	M24x2	94	45	126	12	33	35	42	36	35.5	7	51	83	0.625
SI30C SI30ET-2RS	30	22	20	73	M30x2	110	54	146.5	15	37.5	42	50	46	40.7	6	65	110	0.976
SI35ET-2RS	35	25	22	82	M36x3	125	60	166	15	40	48	58	55	47	6	112	146	1.52
SI40ET-2RS	40	28	24	92	M39x3	142	65	188	18	47	52	65	60	53	7	140	180	2.06
SI45ET-2RS	45	32	28	102	M42x3	145	65	196	20	52	58	70	65	60	7	180	240	2.72
SI50ET-2RS	50	35	31	112	M45x3	160	68	216	20	57	62	75	70	66	6	220	290	3.57
SI60ET-2RS	60	44	39	135	M52x3	175	70	242.5	20	68.5	70	88	80	80	6	345	450	5.63
SI70ET-2RS	70	49	43	160	M56x4	200	80	280	20	81	80	98	85	92	6	440	610	8.33
SI80ET-2RS	80	55	48	180	M64x4	230	85	320	25	91	95	110	95	105	6	567	750	13.04

Can supply rod ends with different pitch or accuracy of thread.

For left-hand thread, suffix "L" is added to bearing numbers. eg.: SI120ET-2RS M20 x 1.5L-6H:

SA..C & SA..ET-2RS

Body: Carbon steel Zinc plated, chromate treated

SA..C: Mounted with GE..C type of radial spherical plain bearings.

SA..ET-2RS: Mounted with GE..ET-2RS type of radial spherical plain bearings.

Sliding contact surfaces: SA..C Steel/PTFE composite
SA..ET-2RS Steel/PTFE fabric

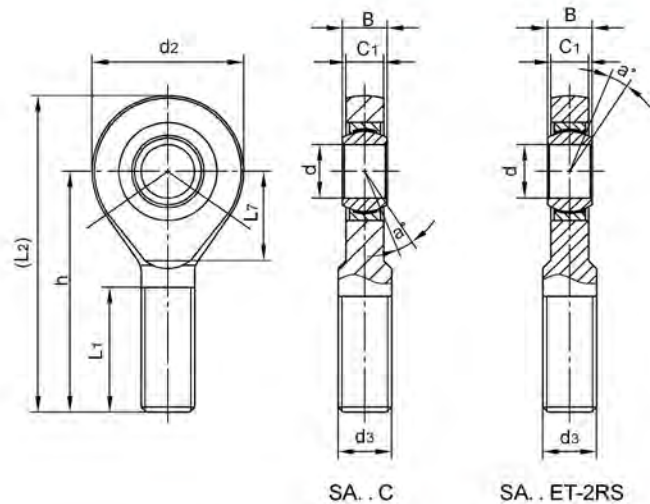

Bearing No.	Dimensions(mm)									Ball dia	a° mis. angle	Load ratings (KN)		Weight ≈ kg
	d	B	C1	d2	d3-6g	h	L1	L2	L7			Dynamic	Static	
SA5C	5	6	4.5	21	M5	36	16	46.5	12	10	13	3.6	4.6	0.017
SA6C	6	6	4.5	21	M6	36	16	46.5	12	10	13	3.6	6.9	0.017
SA8C	8	8	6.5	24	M8	42	21	54	13	13	15	5.8	12.9	0.029
SA10C	10	9	7.5	29	M10	48	26	62.5	16	16	12	8.6	17.6	0.044
SA12C	12	10	8.5	34	M12	54	28	71	18	18	10	11	24.5	0.066
SA15C SA15ET-2RS	15	12	10.5	40	M14	63	34	83	22	22	8	18	36	0.121
SA17C SA17ET-2RS	17	14	11.5	46	M16	69	36	92	24	25	10	22	45	0.172
SA20C SA20ET-2RS	20	16	13.5	53	M20x1.5	78	43	104.5	27	29	9	31	60	0.283
SA25C SA25ET-2RS	25	20	18	64	M24x2	94	53	126	33	35.5	7	51	83	0.504
SA30C SA30ET-2RS	30	22	20	73	M30x2	110	65	146.5	37.5	40.7	6	65	110	0.835
SA35ET-2RS	35	25	22	82	M36x3	140	82	181	41	47	6	112	146	1.41
SA40ET-2RS	40	28	24	92	M39x3	150	86	196	47	53	7	140	180	1.86
SA45ET-2RS	45	32	28	102	M42x3	163	92	214	52	60	7	180	240	2.57
SA50ET-2RS	50	35	31	112	M45x3	185	104	241	60	66	6	220	290	3.58
SA60ET-2RS	60	44	39	135	M52x3	210	115	277.5	75.5	80	6	345	450	5.73
SA70ET-2RS	70	49	43	160	M56x4	235	125	315	95	92	6	440	610	7.94
SA80ET-2RS	80	55	48	180	M64x4	270	140	360	105.5	105	6	567	750	12.06

Can supply rod ends with different pitch or accuracy of thread.

For left-hand thread, suffix "L" is added to bearing numbers. eg.: SAL20ET-2RS M20 x 1.5L-6g;

PHSB..

Ball: Gcr15 Steel, heat treated, HRC56min;
 precision ground, polished, hard
 chromium plated

Body: Carbon steel, zinc plated,chromate treated

Race: Brass

Sliding contact surfaces: Steel/Brass

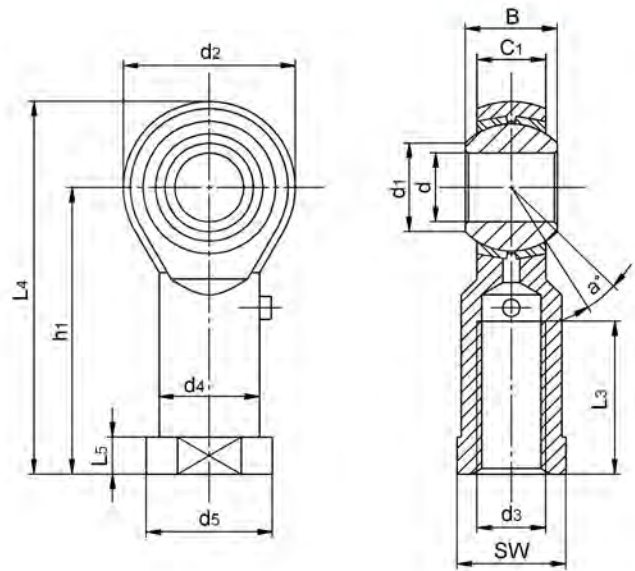

Bearing No.	Dimensions(mm)													Ball dia	a° mis. angle	Load ratings (KN)		weight ≈ kg
	d ^{+0.038 -0.012}	B	C1	d1	d2	d3 _{UNF-2B}	h1	L3	(L4)	L5	d4	d5	SW			Dynamic Cr	Static Cor	
PHSB3	4.826	7.92	6.35	7.77	15.88	10-32	26.97	12.7	34.91	4.75	7.92	10.31	7.92	11.11	10	2.8	7.4	0.015
PHSB4	6.35	9.53	7.14	9.02	19.05	1/4-28	33.32	17.45	42.85	4.75	9.52	11.89	9.53	12.7	13	4.8	11.2	0.025
PHSB5	7.938	11.10	8.74	11.35	22.23	5/16-24	34.93	17.45	46.03	4.75	11.1	12.7	11.1	15.87	10	5.9	13.8	0.036
PHSB6	9.525	12.7	10.31	13.13	25.4	3/8-24	41.28	20.62	53.98	6.35	14.27	17.45	14.27	18.26	9	8.2	18.2	0.061
PHSB7	11.112	14.27	11.1	14.88	28.58	7/16-20	46.02	23.8	60.3	6.35	15.88	19.05	15.88	20.62	11	10	22	0.081
PHSB8	12.7	15.88	12.7	17.73	33.32	1/2-20	53.98	26.97	70.64	6.35	19.05	22.22	19.05	23.8	9	15	31.7	0.133
PHSB10	15.875	19.05	14.27	21.31	38.1	5/8-18	63.5	34.92	82.55	7.92	22.22	25.4	22.22	28.57	11	18	35.1	0.190
PHSB12	19.05	22.23	17.45	24.84	44.45	3/4-16	73.03	39.67	95.25	7.92	25.4	28.58	25.4	33.33	10	27	49.6	0.285
PHSB16	25.4	34.93	25.4	32.23	69.85	5/4-12	104.78	53.98	139.7	11.1	38.1	44.45	38.1	47.62	14	60	101	1.000

Can supply rod ends with different pitch or accuracy of thread.

For left-hand thread, suffix"L" is added to bearing numbers. eg.: PHSB12L 3/4-16L

CF..

Ball: Gcr15 Steel, heat treated HRC56min;
precision ground, polished, hard
chromium plated

Body: Carbon steel, zinc plated,chromate treated

Sliding contact surfaces: Steel/Steel

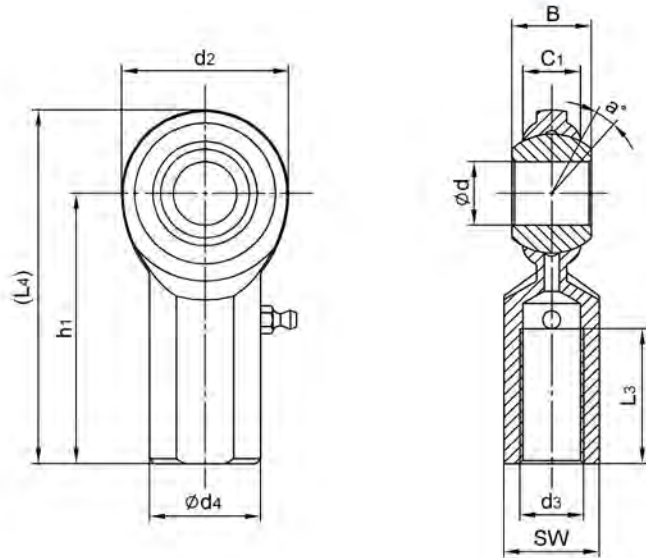

Bearing No.	Dimensions(mm/inches)										Ball dia	a° mis. angle	Load ratings (KN)	weight ≈ kg
	d ₁ ^{+0.038/-0.012}	B	C ₁	d ₂	d ₃ _{UNF-2B}	h ₁	L ₃	(L ₄)	d ₄	SW				
CF3	4.826	7.92	5.94	15.88	10-32	26.97	11.11	34.91	10.31	7.92	11.11	13	7.6	0.182
	0.1900	0.312	0.234	0.625		1.062	0.437	1.375	0.406	0.312	0.437			
CF4	6.35	9.53	6.35	19.05	1/4-28	33.32	14.28	42.85	11.89	9.52	12.7	18	9.9	0.226
	0.2500	0.375	0.250	0.750		1.312	0.562	1.687	0.468	0.375	0.500			
CF5	7.938	11.1	7.92	22.23	5/16-24	34.92	15.88	46.03	12.7	11.1	15.88	14	12.7	0.362
	0.3125	0.437	0.312	0.875		1.375	0.625	1.812	0.500	0.437	0.625			
CF6	9.525	12.7	9.11	25.4	3/8-24	41.28	19.05	53.98	17.45	14.27	18.26	14	17	0.059
	0.3750	0.500	0.359	1.000		1.625	0.750	2.125	0.687	0.562	0.719			
CF7	11.112	14.27	10.31	28.58	7/16-20	46.02	22.22	60.3	19.05	15.88	20.62	13	21	0.081
	0.4375	0.562	0.406	1.125		1.812	0.875	2.375	0.750	0.625	0.812			
CF8	12.7	15.88	11.5	33.33	1/2-20	53.98	25.4	70.64	22.22	19.05	23.8	12	27.5	0.131
	0.5000	0.625	0.453	1.312		2.125	1.000	2.781	0.875	0.750	0.937			
CF10	15.875	19.05	12.29	38.1	5/8-18	63.5	31.75	82.55	25.4	22.22	28.58	16	29.9	0.195
	0.6250	0.750	0.484	1.500		2.5	1.250	3.250	1.000	0.875	1.125			
CF12	19.05	22.23	15.06	44.45	3/4-16	73.02	38.1	95.25	28.58	25.4	33.33	14	44.2	0.294
	0.7500	0.875	0.593	1.750		2.875	1.500	3.75	1.125	1.000	1.312			
CF16	25.4	34.93	25.4	69.85	5/4-12	104.78	53.98	139.7	41.28	38.1	47.62	14	129.1	0.925
	1.0000	1.375	1.000	2.750		4.125	2.125	5.5	1.625	1.500	1.875			

Note:For grease fittings add "Z" to suffix example: CF6Z

Can supply rod ends with different pitch or accuracy of thread.

For left-hand thread, suffix"L" is added to bearing numbers. eg.: CFL12 3/4-16L

CM..

Ball: Gcr15 Steel, heat treated, HRC56min;
precision ground, polished, hard chromium plated

Body: Carbon steel, zinc plated,chromate treated

Sliding contact surfaces: Steel/Steel

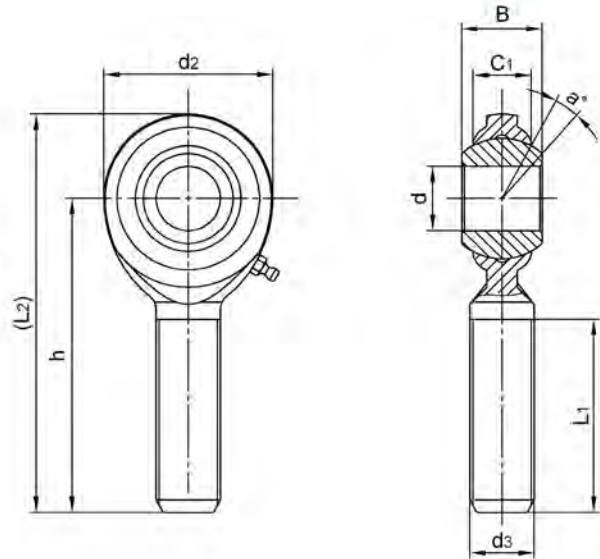

Bearing No.	Dimensions(mm/inches)								Ball dia	a° mis. angle	Load ratings (KN)	weight ≈ kg
	d ^{+0.038} / _{-0.012}	B	C ₁	d ₂	d ₃ UNF-2A	h	L ₁	(L ₂)				
CM3	4.826	7.92	5.94	15.88	10-32	31.75	19.05	39.69	11.112	13	4.4	0.136
	0.1900	0.312	0.234	0.625		1.250	0.750	1.562	0.437			
CM4	6.35	9.53	6.35	19.05	1/4-28	39.67	25.4	49.2	12.7	18	8.2	0.018
	0.2500	0.375	0.250	0.750		1.562	1.000	1.937	0.500			
CM5	7.938	11.10	7.92	22.23	5/16-24	47.63	31.75	58.75	15.875	14	12.7	0.317
	0.3125	0.437	0.312	0.875		1.875	1.250	2.312	0.625			
CM6	9.525	12.7	9.11	25.4	3/8-24	49.22	31.75	61.92	18.263	14	17	0.498
	0.3750	0.500	0.359	1.000		1.938	1.250	2.687	0.719			
CM7	11.11	14.27	10.31	28.58	7/16-20	53.98	34.93	68.27	20.625	13	21	0.068
	0.4375	0.562	0.406	1.125		2.125	1.375	2.678	0.812			
CM8	12.7	15.88	11.5	33.32	1/2-20	61.92	38.1	78.58	23.8	12	27.5	0.108
	0.5000	0.625	0.453	1.312		2.438	1.500	3.093	0.937			
CM10	15.875	19.05	12.29	38.1	5/8-18	66.68	41.28	85.73	28.575	16	29.9	0.163
	0.6250	0.750	0.484	1.500		2.625	1.625	3.375	1.125			
CM12	19.05	22.23	15.06	44.45	3/4-16	73.02	44.45	95.25	33.338	14	44.2	0.258
	0.7500	0.875	0.593	1.750		2.875	1.750	3.750	1.312			
CM14	22.225	22.23	15.06	50.8	7/8-14	85.73	47.63	111.1	33.338	14	74.7	0.408
	0.8750	0.875	0.593	2.000		3.375	1.875	4.375	1.312			
CM16	25.4	34.93	25.4	69.85	5/4-12	104.78	53.98	139.7	47.625	14	129.1	0.964
	1.0000	1.375	1.000	2.750		4.125	2.125	5.500	1.875			

Note: For grease fittings add "Z" to suffix example: CM6Z

Can supply rod ends with different pitch or accuracy of thread.

For left-hand thread, suffix"L" is added to bearing numbers. eg.: CML12 3/4-16L

CF..T

Ball: Gcr15 Steel, heat treated, HRC56min;
precision ground, polished hard
chromium plated

Body: Carbon steel zinc plated,chromate treated

Race: PTFE composite or PTFE fabric

Sliding contact surfaces: Steel/PTFE

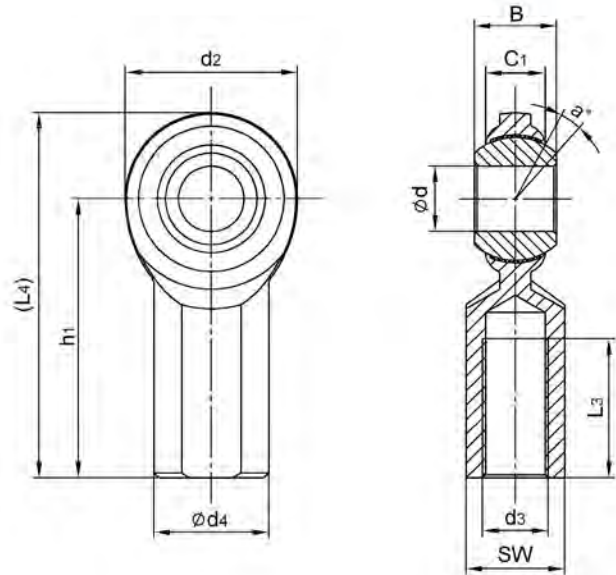

Bearing No.	Dimensions(mm/inches)										Ball dia	a° mis. angle	Load ratings (KN)	weight ≈ kg
	d ^{+0.038 -0.012}	B	C ₁	d ₂	d ₃ UNF-2B	h ₁	L ₃	(L ₄)	d ₄	SW				
CF3T	4.826	7.92	5.94	15.88	10-32	26.97	11.11	34.91	10.31	7.92	11.11	13	5.8	0.018
	0.1900	0.312	0.234	0.625		1.062	0.437	1.375	0.406	0.312	0.437			
CF4T	6.35	9.53	6.35	19.05	1/4-28	33.32	14.28	42.85	11.89	9.52	12.7	18	8.2	0.022
	0.2500	0.375	0.250	0.750		1.312	0.562	1.687	0.468	0.375	0.500			
CF5T	7.938	11.10	7.92	22.23	5/16-24	34.92	15.88	46.03	12.7	11.1	15.88	14	10.2	0.036
	0.3125	0.437	0.312	0.875		1.375	0.625	1.812	0.500	0.437	0.625			
CF6T	9.525	12.7	9.11	25.4	3/8-24	41.28	19.05	53.98	17.45	14.27	18.26	14	14	0.059
	0.3750	0.500	0.359	1.000		1.625	0.750	2.125	0.687	0.562	0.719			
CF7T	11.112	14.27	10.31	28.58	7/16-20	46.02	22.22	60.3	19.05	15.88	20.62	13	17.6	0.081
	0.4375	0.562	0.406	1.125		1.812	0.875	2.375	0.750	0.625	0.812			
CF8T	12.7	15.88	11.5	33.32	1/2-20	53.98	25.4	70.64	22.22	19.05	23.8	12	23.7	0.131
	0.500	0.625	0.453	1.312		2.125	1.000	2.781	0.875	0.750	0.937			
CF10T	15.875	19.05	12.29	38.1	5/8-18	63.5	31.75	82.55	25.4	22.22	28.58	16	25.7	0.195
	0.6250	0.750	0.484	1.500		2.5	1.250	3.250	1.000	0.875	1.125			
CF12T	19.05	22.23	15.06	44.45	3/4-16	73.02	38.1	95.25	28.58	25.4	33.33	14	42.4	0.294
	0.7500	0.875	0.593	1.750		2.875	1.500	3.75	1.125	1.000	1.312			

Can supply rod ends with different pitch or accuracy of thread.

For left-hand thread, suffix "L" is added to bearing numbers. eg.: CFL12T 3/4-16L

CM..T

Ball: Gcr15 Steel, heat treated, HRC56min;
precision ground polished,hard chromium plated

Body: Carbon steel zinc plated,chromate treated

Race: PTFE composite or PTFE fabric

Sliding contact surfaces: Steel/PTFE

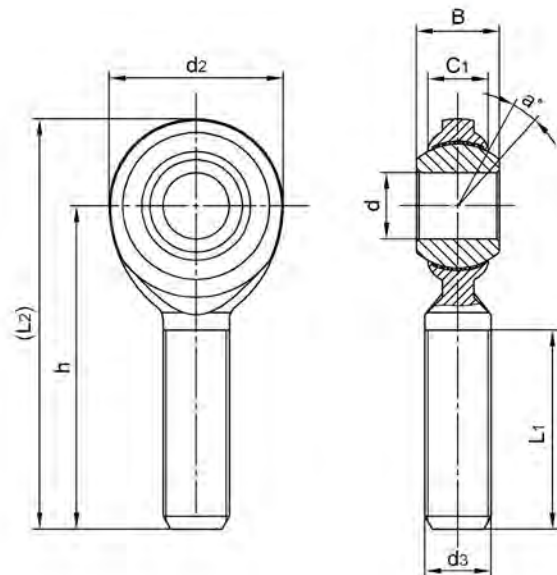

Bearing No.	Dimensions(mm/inches)								Ball dia	a° mis. angle	Load ratings (KN)	weight ≈ kg
	d ^{+0.038} / _{-0.012}	B	C ₁	d ₂	d ₃ UNF-2A	h	L ₁	(L ₂)				
CM3T	4.826	7.92	5.94	15.88	10-32	31.75	19.05	39.69	11.112	13	4.4	0.013
	0.1900	0.312	0.234	0.625		1.250	0.750	1.562	0.437			
CM4T	6.35	9.53	6.35	19.05	1/4-28	39.67	25.4	49.2	12.7	18	8.2	0.018
	0.2500	0.375	0.250	0.750		1.562	1.000	1.937	0.500			
CM5T	7.938	11.10	7.92	22.23	5/16-24	47.63	31.75	58.75	15.875	14	12.7	0.031
	0.3125	0.437	0.312	0.875		1.875	1.250	2.312	0.625			
CM6T	9.525	12.7	9.11	25.4	3/8-24	49.22	31.75	61.92	18.263	14	14	0.049
	0.3750	0.500	0.359	1.000		1.938	1.250	2.437	0.719			
CM7T	11.112	14.27	10.31	28.58	7/16-20	53.98	34.93	68.27	20.625	13	17.6	0.068
	0.4375	0.562	0.406	1.125		2.125	1.375	2.678	0.812			
CM8T	12.7	15.88	11.5	33.32	1/2-20	61.92	38.1	78.58	23.8	12	23.7	0.108
	0.5000	0.625	0.453	1.312		2.438	1.500	3.093	0.937			
CM10T	15.875	19.05	12.29	38.1	5/8-18	66.68	41.28	85.73	28.575	16	25.7	0.163
	0.6250	0.750	0.484	1.500		2.625	1.625	3.375	1.125			
CM12T	19.05	22.23	15.06	44.45	3/4-16	73.02	44.45	95.25	33.338	14	42.4	0.258
	0.7500	0.875	0.593	1.750		2.875	1.750	3.750	1.312			
CM14T	22.225	22.23	15.06	50.8	7/8-14	85.73	47.63	111.1	33.338	14	70.8	0.408
	0.8750	0.875	0.593	2.000		3.375	1.875	4.375	1.312			

Can supply rod ends with different pitch or accuracy of thread.

For left-hand thread, suffix"L" is added to bearing numbers. eg.: CML12T 3/4-16L

CF..TY

Ball: Gcr15 Steel, heat treated, HRC56min;
precision ground, polished hard
chromium plated

Body: Carbon steel zinc plated,chromate treated

Liner: PTFE composite or PTFE fabric

Stud: Low carbon steel, zinc plated

Sliding contact surfaces: Steel/PTFE Composite
or Steel/PTFE fabric

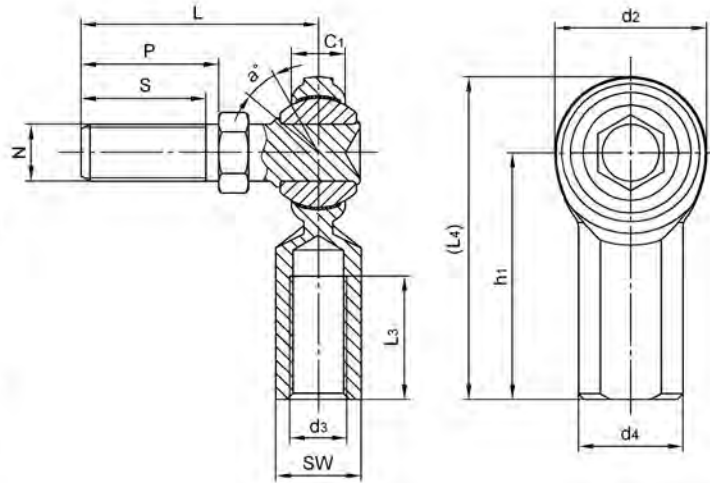

Bearing No	Dimensions(mm/inches)												Ball dia	a° mis. angle	Load ratings (KN)	weight ≈ kg
	d2	C1	d3 UWF-2B	d4	SW	h1	L3	(L4)	N UWF-2A	S	P	L				
CF3TY	15.88	5.94	10-32	10.31	7.92	26.97	11.1	34.91	10-32	11.1	12.7	25.8	11.11	22	4.4	0.022
	0.625	0.234		0.406	0.312	1.062	0.437	1.375		0.437	0.500	1.016	7/16			
CF4TY	19.05	6.35	1/4-28	11.89	9.52	33.32	14.27	42.85	1/4-28	12.7	14.27	26.18	12.7	20	8.2	0.027
	0.750	0.250		0.468	0.375	1.312	0.562	1.687		0.500	0.562	1.031	1/2			
CF5TY	22.23	7.92	5/16-24	12.7	11.1	34.92	15.88	46.03	5/16-24	15.06	17.45	30.96	15.88	21	10.2	0.048
	0.875	0.312		0.500	0.437	1.375	0.625	1.812		0.593	0.687	1.219	5/8			
CF6TY	25.4	9.11	3/8-24	17.45	14.27	41.28	19.05	53.98	3/8-24	20.62	23	39.67	18.26	23	14	0.077
	1.000	0.359		0.687	0.562	1.625	0.750	2.125		0.812	0.906	1.562	23/32			
CF7TY	28.58	10.31	7/16-20	19.05	15.88	46.02	22.22	60.3	7/16-20	23.8	26.97	44.45	20.62	22	17.6	0.122
	1.125	0.406		0.750	0.625	1.812	0.875	2.375		0.937	1.062	1.750	13/16			
CF8TY	33.33	11.5	1/2-20	22.22	19.05	53.98	25.4	70.64	1/2-20	25.4	28.58	50.8	23.8	24	23.7	0.181
	1.312	0.453		0.875	0.750	2.125	1.000	2.781		1.000	1.125	2.000	15/16			
CF10TY	38.1	12.3	5/8-18	25.4	22.22	63.5	31.75	82.55	5/8-18	34.93	38.1	63.5	28.58	26	25.7	0.308
	1.500	0.484		1.000	0.875	2.5	1.250	3.250		1.375	1.500	2.500	9/8			
CF12TY	44.45	15.06	3/4-16	28.58	25.4	73.03	38.1	95.25	3/4-16	41.28	46.02	76.2	33.33	23	42.4	0.503
	1.750	0.593		1.125	1.000	2.875	1.500	3.75		1.625	1.812	3.000	21/16			

Can supply rod ends with different pitch or accuracy of thread.

For left-hand thread, suffix"L" is added to bearing numbers. eg.: CFL6TY 3/8-24L

CM..TY

Ball: Gcr15 Steel, heat treated, HRC56min;
precision ground, polished, hard
chromium plated

Body: Carbon steel zinc plated, chromate treated

Liner: PTFE composite or PTFE fabric

Stud: Low carbon steel, zinc plated

Sliding contact surfaces: Steel/PTFE Composite
or Steel/PTFE fabric

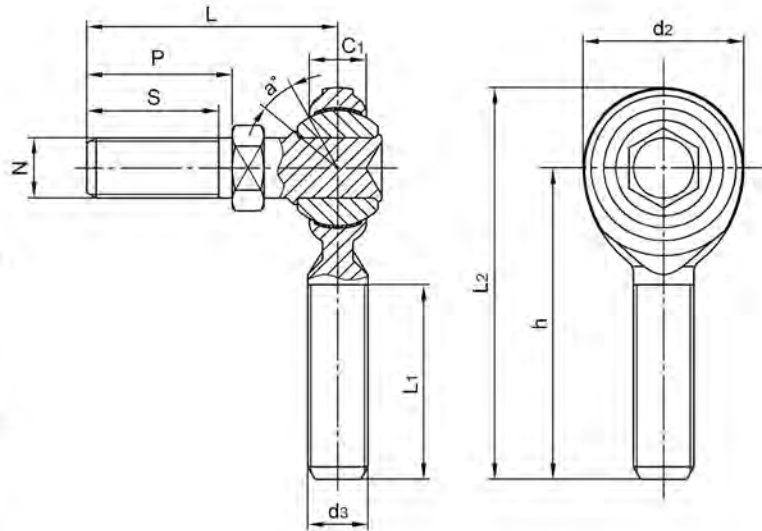

Bearing No.	Dimensions(mm/inches)										Ball dia	a° mis. angle	Load ratings (KN)	weight ≈ kg
	d2	C1	d3 UNF-2A	h	L1	(L4)	N UNF-2A	S	P	L				
CM3TY	15.88	5.94	10-32	31.75	19.05	39.69	10-32	11.1	12.7	25.8	11.11	22	4.4	0.018
	0.625	0.234		1.250	0.750	1.562		0.437	0.500	1.016	7/16			
CM4TY	19.05	6.35	1/4-28	39.67	25.4	49.2	1/4-28	12.7	14.27	26.18	12.7	20	8.2	0.022
	0.750	0.250		1.562	1.000	1.937		0.500	0.562	1.031	1/2			
CM5TY	22.23	7.92	5/16-24	47.63	31.75	58.75	5/16-24	15.06	17.45	30.96	15.88	21	10.2	0.045
	0.875	0.312		1.875	1.250	2.312		0.593	0.687	1.219	5/8			
CM6TY	25.4	9.11	3/8-24	49.23	31.75	61.92	3/8-24	20.62	23	39.67	18.26	23	14	0.068
	1.000	0.359		1.938	1.250	2.437		0.812	0.906	1.562	23/32			
CM7TY	28.58	10.31	7/16-20	53.98	34.93	68.27	7/16-20	23.8	26.97	44.45	20.62	22	17.6	0.108
	1.125	0.406		2.125	1.375	2.678		0.937	1.062	1.750	13/16			
CM8TY	33.33	11.5	1/2-20	61.93	38.1	78.58	1/2-20	25.4	28.58	50.8	23.8	24	23.7	0.158
	1.312	0.453		2.438	1.500	3.093		1.000	1.125	2.000	15/16			
CM10TY	38.1	12.3	5/8-18	66.68	41.28	85.73	5/8-18	34.93	38.1	63.5	28.57	26	25.7	0.276
	1.500	0.484		2.625	1.625	3.375		1.375	1.500	2.500	9/8			
CM12TY	44.45	15.06	3/4-16	73.03	44.45	95.25	3/4-16	41.28	46.02	76.2	33.33	23	42.4	0.467
	1.750	0.593		2.875	1.750	3.750		1.625	1.812	3.000	21/16			

Can supply rod ends with different pitch or accuracy of thread.

For left-hand thread, suffix"L" is added to bearing numbers. eg.: CML6TY 3/8-24L

F..

Ball: Gcr15 Steel, heat treated, HRC56min;
precision ground, polished, hard
chromium plated

Body: Carbon steel zinc plated,chromate treated

Race: Brass

Sliding contact surfaces: Steel/Brass

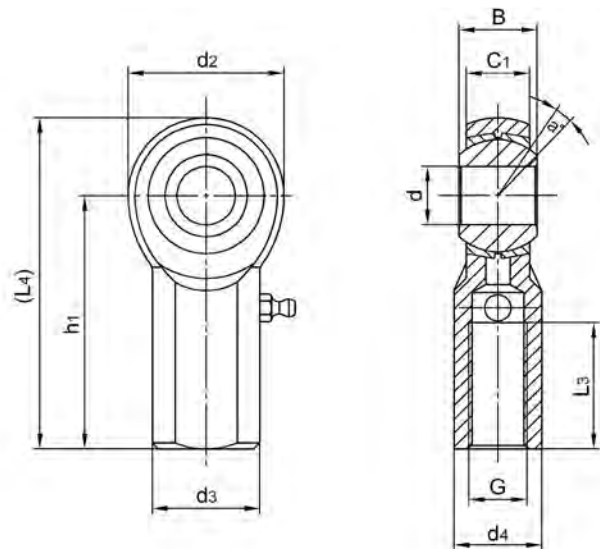

Bearing No.	Dimensions(mm/inches)										Ball dia	a° mis. angle	Load ratings (KN)	weight ≈ kg
	d ^{+0.038 -0.012}	B	C ₁	d ₂	d ₃ UNF-2B	h ₁	L ₃	(L ₄)	d ₄	SW				
F3	4.826	7.92	6.35	15.88	10-32	26.97	11.11	34.91	10.31	7.92	11.11	10	7.6	0.018
	0.1900	0.312	0.250	0.625		1.062	0.437	1.375	0.406	0.312	0.437			
F4	6.35	9.53	7.14	19.05	1/4-28	33.32	14.28	42.85	11.89	9.52	12.7	13	11.3	0.027
	0.2500	0.375	0.281	0.750		1.312	0.562	1.687	0.468	0.375	0.500			
F5	7.938	11.10	8.74	22.23	5/16-24	34.92	15.88	46.03	12.7	11.1	15.88	10	14.5	0.04
	0.3125	0.437	0.344	0.875		1.375	0.625	1.812	0.500	0.437	0.625			
F6	9.525	12.7	10.31	25.4	3/8-24	41.28	19.05	53.98	17.45	14.27	18.26	9	18.5	0.068
	0.3750	0.500	0.406	1.000		1.625	0.750	2.125	0.687	0.562	0.719			
F7	11.112	14.27	11.1	28.58	7/16-20	46.02	22.22	60.3	19.05	15.88	20.62	11	22.3	0.09
	0.4375	0.562	0.437	1.125		1.812	0.875	2.375	0.750	0.625	0.812			
F8	12.7	15.88	12.7	33.32	1/2-20	53.98	25.4	70.64	22.22	19.05	23.8	9	32	0.149
	0.5000	0.625	0.500	1.312		2.125	1.000	2.781	0.875	0.750	0.937			
F10	15.875	19.05	14.27	38.1	5/8-18	63.5	31.75	82.55	25.4	22.22	28.58	11	35.5	0.217
	0.6250	0.750	0.562	1.500		2.5	1.250	3.250	1.000	0.875	1.125			
F12	19.05	22.23	17.45	44.45	3/4-16	73.02	38.1	95.25	28.58	25.4	33.33	10	50.2	0.326
	0.7500	0.875	0.678	1.750		2.875	1.500	3.75	1.125	1.000	1.312			
F16	25.4	34.93	25.4	69.85	5/4-12	104.78	53.98	139.7	41.28	38.1	47.62	14	164.2	0.963
	1.0000	1.375	1.000	2.750		4.125	2.125	5.5	1.625	1.500	1.875			

Note: For grease fittings add "Z" to suffix example: F6Z

Can supply rod ends with different pitch or accuracy of thread.

For left-hand thread, suffix"L" is added to bearing numbers. eg.: FL12 3/4-16L



M..

- Ball: Gcr15 Steel, heat treated, HRC56min;
precision ground, polished hard
chromium plated
- Body: Carbon steel, zinc plated,chromate treated
- Race: Brass
- Sliding contact surfaces: Steel/Brass

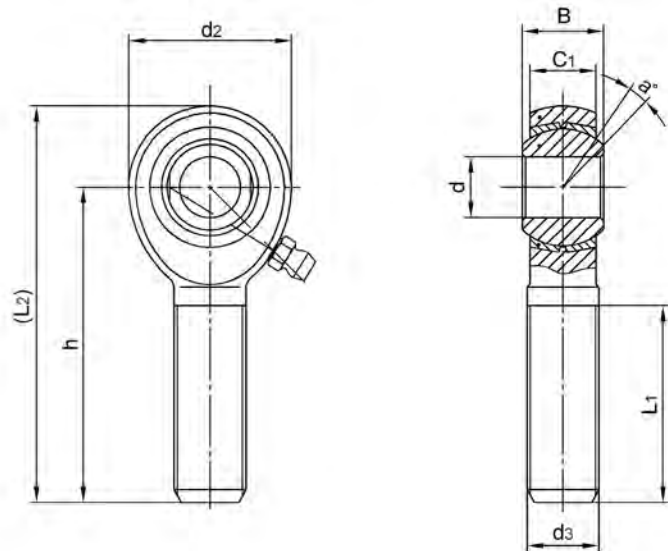

Bearing No.	Dimensions(mm/inches)								Ball dia	a° mis. angle	Load ratings (KN)	weight ≈ kg
	d ^{+0.036} _{-0.012}	B	C ₁	d ₂	d ₃ _{UNF-2A}	h	L ₁	(L ₂)				
M3	4.826	7.92	6.35	15.88	10-32	31.75	19.05	39.69	11.11	10	4.4	0.013
	0.1900	0.312	0.250	0.625		1.250	0.750	1.562	0.437			
M4	6.35	9.53	7.14	19.05	1/4-28	39.67	25.4	49.2	12.7	13	8.2	0.018
	0.2500	0.375	0.281	0.750		1.562	1.000	1.937	0.500			
M5	7.938	11.10	8.74	22.23	5/16-24	47.63	31.75	58.75	15.88	10	13.1	0.031
	0.3125	0.437	0.344	0.875		1.875	1.250	2.312	0.625			
M6	9.525	12.7	10.31	25.4	3/8-24	49.22	31.75	61.92	18.26	9	14.6	0.049
	0.3750	0.500	0.406	1.000		1.938	1.250	2.437	0.719			
M7	11.112	14.27	11.1	28.58	7/16-20	53.98	34.93	68.27	20.62	11	19.5	0.072
	0.4375	0.562	0.437	1.125		2.125	1.375	2.678	0.812			
M8	12.7	15.88	12.7	33.32	1/2-20	61.92	38.1	78.58	23.8	9	29.4	0.113
	0.5000	0.625	0.500	1.312		2.438	1.500	3.093	0.937			
M10	15.875	19.05	14.27	38.1	5/8-18	66.68	41.28	85.73	28.58	11	35.5	0.172
	0.6250	0.750	0.562	1.500		2.625	1.625	3.375	1.125			
M12	19.05	22.23	17.45	44.45	3/4-16	73.02	44.45	95.25	33.33	10	50.2	0.272
	0.7500	0.875	0.687	1.750		2.875	1.750	3.750	1.312			
M14	22.225	22.23	17.45	50.8	7/8-14	85.73	47.63	111.1	33.33	10	85	0.408
	0.8750	0.875	0.687	2.000		3.375	1.875	4.375	1.312			
M16	25.4	34.93	25.4	69.85	5/4-12	104.78	53.98	139.7	47.63	14	152.5	1.091
	1.0000	1.375	1.000	2.750		4.125	2.125	5.500	1.875			

Note: For grease fittings add " Z" to suffix example: M6Z

Can supply rod ends with different pitch or accuracy of thread.

For left-hand thread, suffix"L" is added to bearing numbers. eg.: ML12 3/4-16L

JF..

Ball: Gcr15 Steel, heat treated, HRC56min;
precision ground, polished hard
chromium plated

Body: Carbon steel, zinc plated, chromate treated

Race: Steel alloy, zinc plated, chromate treated

Sliding contact surfaces: Steel/Steel or

Steel/PTFE Composite

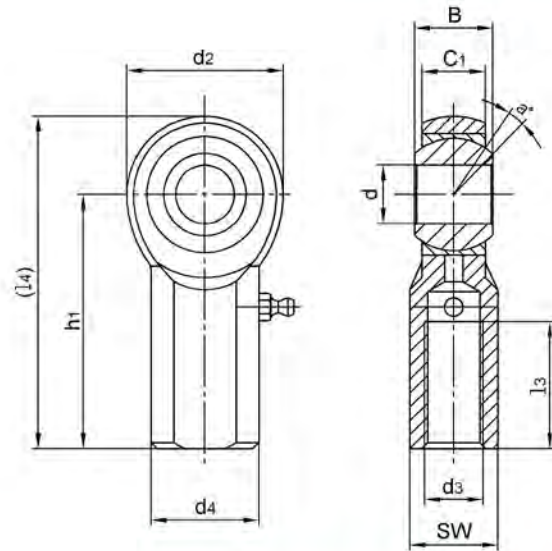

Bearing No.	Dimensions(mm/inches)										Ball dia	a° mis. angle	Load ratings (KN)	weight ≈ kg
	d ^{+0.038 -0.012}	B	C1	d2	d3 UNF-2B	h1	l3	(l4)	d4	SW				
JF3	4.826	7.92	6.35	15.88	10-32	26.97	11.11	34.91	10.31	7.92	11.11	10	5.4	0.018
	0.1900	0.312	0.250	0.625		1.062	0.437	1.375	0.406	0.312	0.437			
JF4	6.35	9.53	7.14	19.05	1/4-28	33.32	14.28	42.85	11.89	9.52	12.7	13	9.0	0.027
	0.2500	0.375	0.281	0.750		1.312	0.562	1.687	0.468	0.375	0.500			
JF5	7.938	11.10	8.74	22.23	5/16-24	34.92	15.88	46.03	12.7	11.1	15.88	10	11.1	0.04
	0.3125	0.437	0.344	0.875		1.375	0.625	1.812	0.500	0.437	0.625			
JF6	9.525	12.7	10.31	25.4	3/8-24	41.28	19.05	53.98	17.45	14.27	18.26	9	13.3	0.068
	0.3750	0.500	0.406	1.000		1.625	0.750	2.125	0.687	0.562	0.719			
JF7	11.11	14.27	11.1	28.58	7/16-20	46.02	22.22	60.3	19.05	15.88	20.62	11	18.5	0.09
	0.4375	0.562	0.437	1.125		1.812	0.875	2.375	0.750	0.625	0.812			
JF8	12.7	15.88	12.7	33.32	1/2-20	53.98	25.4	70.64	22.22	19.05	23.8	9	29.1	0.149
	0.500	0.625	0.500	1.312		2.125	1.000	2.781	0.875	0.750	0.937			
JF10	15.875	19.05	14.27	38.1	5/8-18	63.5	31.75	82.55	25.4	22.22	28.58	11	31.2	0.217
	0.6250	0.750	0.562	1.500		2.5	1.250	3.250	1.000	0.875	1.125			
JF12	19.05	22.23	17.45	44.45	3/4-16	73.03	38.1	95.25	28.58	25.4	33.33	10	44.8	0.326
	0.7500	0.875	0.687	1.750		2.875	1.500	3.75	1.125	1.000	1.312			
JF16	25.4	34.93	25.4	69.85	5/4-12	104.78	53.98	139.7	41.28	38.1	47.62	14		0.963
JF16-1**	1.0000	1.375	1.000	2.750	1-14	4.125	2.125	5.5	1.625	1.500	1.875		155.4	1.093
JF16-2**					1-12								1.093	

Notes: For grease fittings add "Z" to suffix. Example: JF6Z
For studs add "Y" to suffix. Example: JF5Y
For teflon liner add "T" to suffix. Example: JF12T

Can supply rod ends with different pitch or accuracy of thread.

For left-hand thread, suffix "L" is added to bearing numbers. eg.: JFL12T 3/4-16L

JM..

Ball: Gcr15 Steel, heat treated, HRC56min;
 precision ground, polished, hard chromium plated
 Body: Carbon steel zinc plated,chromate treated
 Race: Steel alloy, zinc plated, chromate treated
 Sliding contact surfaces: Steel/Steel or
 Steel/PTFE composite

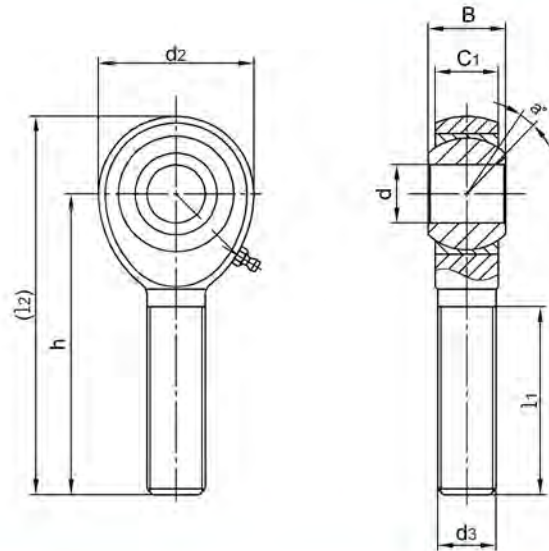

Bearing No.	Dimensions(mm/inches)								Ball dia	a° mis. angle	Load ratings (KN)	weight ≈ kg
	d ^{+0.038} _{-0.012}	B	C ₁	d ₂	d ₃ UNF-2A	h	l ₁	(l ₂)				
JM3	4.826	7.92	6.35	15.88	10-32	31.75	19.05	39.69	11.11	10	4.4	0.013
	0.1900	0.312	0.250	0.625		1.250	0.750	1.562	0.437			
JM4	6.35	9.53	7.14	19.05	1/4-28	39.67	25.4	49.2	12.7	13	8.2	0.018
	0.2500	0.375	0.281	0.750		1.562	1.000	1.937	0.500			
JM5	7.938	11.1	8.74	22.23	5/16-24	47.63	31.75	58.75	15.88	10	11.1	0.031
	0.3125	0.437	0.344	0.875		1.875	1.250	2.312	0.625			
JM6	9.525	12.7	10.31	25.4	3/8-24	49.22	31.75	61.92	18.26	9	13.3	0.049
	0.3750	0.500	0.406	1.000		1.938	1.250	2.437	0.719			
JM7	11.112	14.27	11.1	28.58	7/16-20	53.98	34.93	68.27	20.62	11	18.5	0.072
	0.4375	0.562	0.437	1.125		2.125	1.375	2.678	0.812			
JM8	12.7	15.88	12.7	33.32	1/2-20	61.92	38.1	78.58	23.8	9	29.1	0.113
	0.5000	0.625	0.500	1.312		2.438	1.500	3.093	0.937			
JM10	15.875	19.05	14.27	38.1	5/8-18	66.68	41.28	85.73	28.58	11	31.2	0.172
	0.6250	0.750	0.562	1.500		2.625	1.625	3.375	0.937			
JM12	19.05	22.23	17.45	44.45	3/4-16	73.02	44.45	95.25	28.58	10	44.8	0.272
	0.7500	0.875	0.687	1.750		2.875	1.750	3.750	1.125			
JM14	25.4	22.23	17.45	50.8	7/8-14	85.73	47.63	111.1	33.33	10	85	0.408
	0.8750	0.875	0.687	2.000		3.375	1.875	4.375	1.312			
JM16	25.4	34.93	25.4	69.85	5/4-12	104.78	53.98	139.7	47.63	14	155.4	1.091
JM16-1**	1.0000	1.375	1.000	2.750	1-14	4.125	2.125	5.500	1.875			0.964
JM16-2**					12							0.964

Note: For grease fittings add "Z" to suffix. Example: JM6Z
 For studs add "Y" to suffix. Example: JM5Y
 For teflon liner add "T" to suffix. Example: JM12T

Can supply rod ends with different pitch or accuracy of thread.

For left-hand thread, suffix"L" is added to bearing numbers. eg.: JML12T 3/4-16L

SPHSB..EC

- Ball: 440C Stainless steel, heat treated
HRC56 min, precision ground, polished
- Body: 304 Stainless steel
- Race: PTFE composite
- Sliding contact surfaces: Steel/PTFE composite

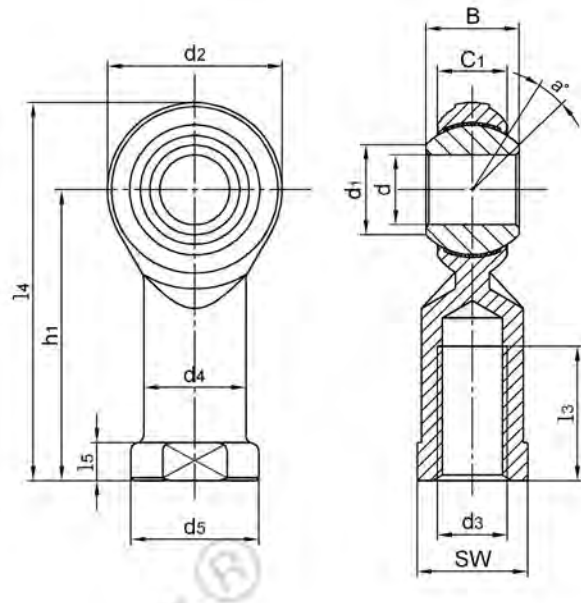

Bearing No.	Dimensions(mm)														Ball dia	a° mis. angle	Load ratings		weight ≈ kg
	d ^{+0.038 -0.012}	B	C ₁	d ₁	d ₂	d ₃ UNF-2B	h ₁	l ₃	(l ₄)	L ₅	d ₄	d ₅	SW	Dynamic C _t			Static Cor		
SPHSB3EC	4.826	7.92	6.35	7.77	15.88	10-32	26.97	12.7	34.91	4.75	7.92	10.31	7.92	11.11	10	3.3	6.6	0.015	
SPHSB4EC	6.35	9.53	7.14	9.02	19.05	1/4-28	33.32	17.45	42.85	4.75	9.52	11.89	9.52	12.7	13	4.8	11	0.025	
SPHSB5EC	7.938	11.10	8.74	11.35	22.23	5/16-24	34.92	17.45	46.03	4.75	11.1	12.7	11.1	15.87	10	5.9	12	0.036	
SPHSB6EC	9.525	12.7	10.31	13.13	25.4	3/8-24	41.28	20.62	53.98	6.35	14.27	17.45	14.27	18.26	9	8.2	18.2	0.061	
SPHSB7EC	11.11	14.27	11.1	14.88	28.58	7/16-20	46.02	23.8	60.3	6.35	15.88	19.05	15.88	20.62	11	10	21.5	0.081	
SPHSB8EC	12.7	15.88	12.7	17.73	33.32	1/2-20	53.98	26.97	70.64	6.35	19.05	22.22	19.05	23.8	9	15	30.6	0.133	
SPHSB10EC	15.88	19.05	14.27	21.31	38.1	5/8-18	63.5	34.92	82.55	7.92	22.22	25.4	22.22	28.57	11	18	34.1	0.190	
SPHSB12EC	19.05	22.23	17.45	24.84	44.45	3/4-16	73.03	39.67	95.25	7.92	25.4	28.58	25.4	33.33	10	27	47.9	0.285	

Can supply rod ends with different pitch or accuracy of thread.

For left-hand thread, suffix "L" is added to bearing numbers. eg.: SPHSB12ECL 3/4-16L

SPOSB..EC

Ball: 440C Stainless steel, heat treated, HRC56 min,

Body: 304 Stainless steel

Race: PTFE composite

Sliding contact surfaces: Steel/PTFE composite

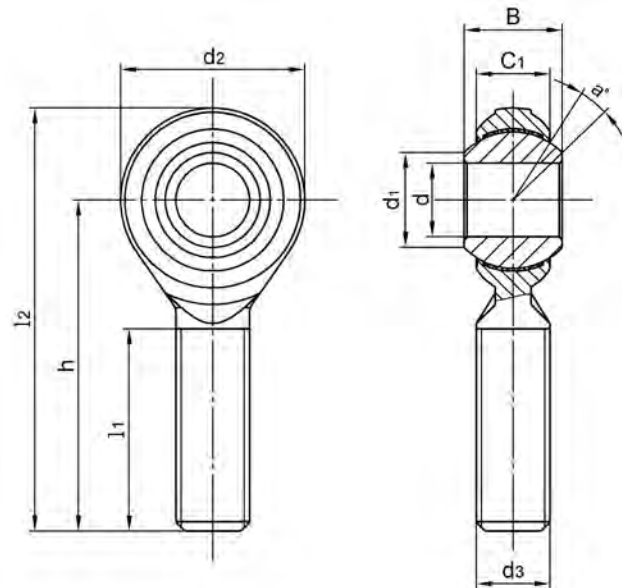

Bearing No.	Dimensions(mm)									Ball dia	a° mis. angle	Load ratings KN		weight ≈ kg
	d ^{+0.038} _{-0.012}	B	C ₁	d ₁	d ₂	d ₃ _{UNF-2A}	h	l ₁	l ₂			Dynamic	Static	
SPOSB3EC	4.826	7.92	6.35	7.77	15.88	10-32	31.75	19.05	39.69	11.11	10	2.8	4.4	0.013
SPOSB4EC	6.35	9.53	7.14	9.02	19.05	1/4-28	39.67	25.4	49.2	12.7	13	4.8	8.2	0.022
SPOSB5EC	7.938	11.10	8.74	11.35	22.23	5/16-24	47.63	31.75	58.75	15.87	10	5.9	13.1	0.037
SPOSB6EC	9.525	12.7	10.31	13.13	25.4	3/8-24	49.22	31.75	61.92	18.26	9	8.2	18.2	0.055
SPOSB7EC	11.11	14.27	11.1	14.88	28.58	7/16-20	53.98	34.93	68.28	20.62	11	10	21.5	0.078
SPOSB8EC	12.7	15.88	12.7	17.73	33.32	1/2-20	61.92	38.1	78.59	23.8	9	15	30.6	0.120
SPOSB10EC	15.88	19.05	14.27	21.31	38.1	5/8-18	66.68	41.28	85.73	28.57	11	18	34.1	0.180
SPOSB12EC	19.05	22.23	17.45	24.84	44.45	3/4-16	73.02	44.45	95.25	33.33	10	27	47.9	0.290

Can supply rod ends with different pitch or accuracy of thread.

For left-hand thread, suffix "L" is added to bearing numbers. eg.: SPOSB12ECL 3/4-16L



SCF..T(SPHSB..EC)

Ball: 440C Stainless steel, heat treated, HRC 56min
precision ground, polished

Body: 304 Stainless steel

Race: PTFE composite or PTFE fabric

Sliding contact surfaces: Steel/PTFE

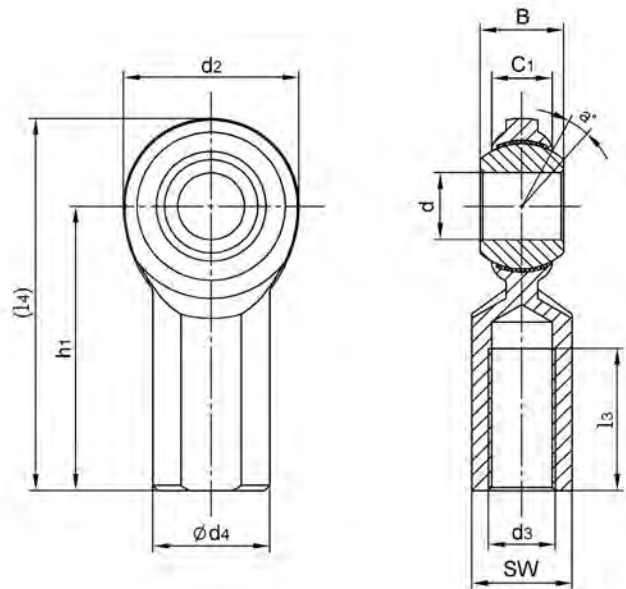

Bearing No.	Dimensions(mm/inches)										Ball dia	α° mis. angle	Load ratings (KN)	weight ≈ kg
	d ^{+0.03} _{-0.01}	B	C ₁	d ₂	d ₃ UNF-2B	h ₁	l ₃	(L ₄)	d ₄	SW				
SCF3T	4.826	7.92	5.94	15.88	10-32	26.97	11.11	34.91	10.31	7.92	11.11	13	5.8	0.018
	0.1900	0.312	0.234	0.625		1.062	0.437	1.375	0.406	0.312	0.437			
SCF4T	6.35	9.53	6.35	19.05	1/4-28	33.32	14.28	42.85	11.89	9.52	12.7	18	8.2	0.022
	0.2500	0.375	0.250	0.750		1.312	0.562	1.687	0.468	0.375	0.500			
SCF5T	7.938	11.10	7.92	22.23	5/16-24	34.92	15.88	46.03	12.7	11.1	15.88	14	10.2	0.036
	0.3125	0.437	0.312	0.875		1.375	0.625	1.812	0.500	0.437	0.625			
SCF6T	9.525	12.7	9.11	25.4	3/8-24	41.28	19.05	53.98	17.45	14.27	18.26	14	14	0.059
	0.3750	0.500	0.359	1.000		1.625	0.750	2.125	0.687	0.562	0.719			
SCF7T	11.112	14.27	10.31	28.58	7/16-20	46.02	22.22	60.3	19.05	15.88	20.62	13	17.6	0.081
	0.4375	0.562	0.406	1.125		1.812	0.875	2.375	0.750	0.625	0.812			
SCF8T	12.7	15.88	11.5	33.32	1/2-20	53.98	25.4	70.64	22.22	19.05	23.8	12	23.7	0.131
	0.5000	0.625	0.453	1.312		2.125	1.000	2.781	0.875	0.750	0.937			
SCF10T	15.875	19.05	12.29	38.1	5/8-18	63.5	31.75	82.55	25.4	22.22	28.58	16	25.7	0.195
	0.6250	0.750	0.484	1.500		2.5	1.250	3.250	1.000	0.875	1.125			
SCF12T	19.05	22.23	15.06	44.45	3/4-16	73.03	38.1	95.25	28.58	25.4	33.33	14	42.4	0.294
	0.7500	0.875	0.593	1.750		2.875	1.500	3.75	1.125	1.000	1.312			

Can supply rod ends with different pitch or accuracy of thread.

For left-hand thread, suffix "L" is added to bearing numbers. eg.: SCFL12T 3/4-16L

SCM..T(SPOSB..EC)

Ball: 440C Stainless steel, heat treated, HRC 56min
precision ground, polished

Body: 304 Stainless steel

Race: PTFE composite or PTFE fabric

Sliding contact surfaces: Steel/PTFE

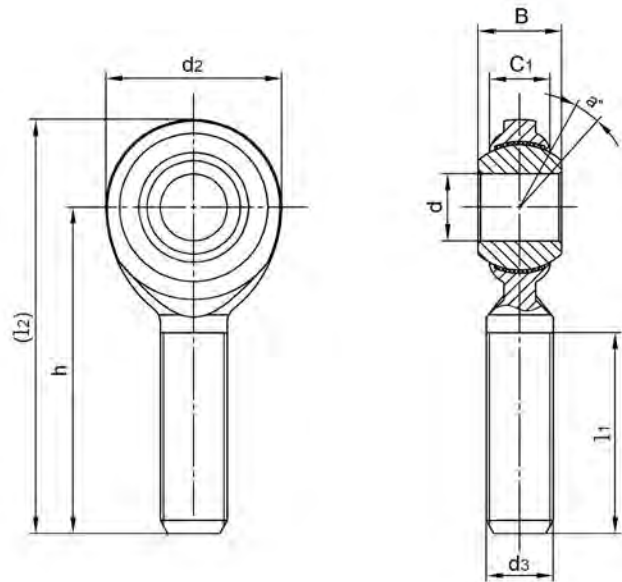

Bearing No.	Dimensions(mm/inches)								Ball dia	a° mis. angle	Load ratings (KN)	weight ≈ kg
	d ^{+0.03} / _{-0.01}	B	C ₁	d ₂	d ₃ UNF-2A	h	l ₁	(l ₂)				
SCM3T	4.826	7.92	5.94	15.88	10-32	31.75	19.05	39.69	11.112	13	4.4	0.013
	0.1900	0.312	0.234	0.625		1.250	0.750	1.562	0.437			
SCM4T	6.35	9.53	6.35	19.05	1/4-28	39.67	25.4	49.2	12.7	18	8.2	0.018
	0.2500	0.375	0.250	0.750		1.562	1.000	1.937	0.500			
SCM5T	7.938	11.10	7.92	22.23	5/16-24	47.63	31.75	58.75	15.875	14	12.7	0.031
	0.3125	0.437	0.312	0.875		1.875	1.250	2.312	0.625			
SCM6T	9.525	12.7	9.11	25.4	3/8-24	49.22	31.75	61.92	18.263	14	14	0.049
	0.3750	0.500	0.359	1.000		1.938	1.250	2.437	0.719			
SCM7T	11.11	14.27	10.31	28.58	7/16-20	53.98	34.93	68.27	20.625	13	17.6	0.068
	0.4375	0.562	0.406	1.125		2.125	1.375	2.678	0.812			
SCM8T	12.7	15.88	11.5	33.32	1/2-20	61.92	38.1	78.58	23.8	12	23.7	0.108
	0.500	0.625	0.453	1.312		2.438	1.500	3.093	0.937			
SCM10T	15.875	19.05	12.29	38.1	5/8-18	66.68	41.28	85.73	28.575	16	25.7	0.163
	0.6250	0.750	0.484	1.500		2.625	1.625	3.375	1.125			
SCM12T	19.05	22.23	15.06	44.45	3/4-16	73.02	44.45	95.25	33.338	14	42.4	0.258
	0.7500	0.875	0.593	1.750		2.875	1.750	3.750	1.312			

Can supply rod ends with different pitch or accuracy of thread.

For left-hand thread, suffix "L" is added to bearing numbers. eg.: SCML12T 3/4-16L

CMX.. CMX..T

Ball: Gcr15 Steel, heat treated, HRC56min;
precision ground, polished hard
chromium plated

Body: Alloy steel, heat treated, Black oxide coated
CMX..

Sliding contact surfaces: Steel/Steel

CMX..T

Sliding contact surfaces: Steel/PTFE Composite or fabric

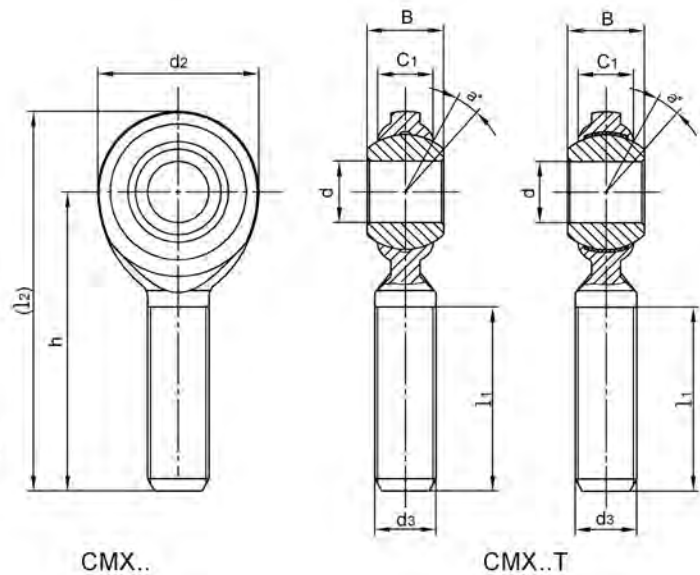

Bearing No.	Dimensions(mm/inches)								Ball dia	a° mis. angle	Load ratings (KN)	weight ≈ kg
	d	B	C1	d2	d3 UNF-2A	h	l1	(l2)				
CMX8	12.7	15.88	11.5	33.32	1/2-20	61.92	38.1	78.58	23.8	12	75.6	0.108
CMX8T	0.500	0.625	0.453	1.312		2.438	1.500	3.093	0.937			
CMX10-8	12.7	19.05	12.29	38.1	5/8-18	66.68	41.28	85.73	28.57	16	80	0.136
CMX10-8T	0.5000	0.750	0.484	1.500		2.625	1.625	3.375	1.125			
CMX10	15.88	19.05	12.29	38.1	5/8-18	66.68	41.28	85.73	28.57	16	80	0.163
CMX10T	0.6250	0.750	0.484	1.500		2.625	1.625	3.375	1.125			
CMX12-8	12.7	22.23	15.06	44.45	3/4-16	73.02	44.45	95.25	33.33	14	111.2	0.258
CMX12-8T	0.5000	0.875	0.593	1.750		2.875	1.750	3.750	1.312			
CMX12-10	15.875	22.23	15.06	44.45	3/4-16	73.02	44.45	95.25	33.33	14	111.2	0.258
CMX12-10T	0.6250	0.875	0.593	1.750		2.875	1.750	3.750	1.312			
CMX12	19.05	22.23	15.06	44.45	3/4-16	73.02	44.45	95.25	33.33	14	111.2	0.258
CMX12T	0.7500	0.875	0.593	1.750		2.875	1.750	3.750	1.312			

Can supply rod ends with different pitch or accuracy of thread.

For left-hand thread, suffix"L" is added to bearing numbers. eg.: CMXL12T 3/4-16L

**JFX
JFX..T**

Ball: Gcr15 Steel, heat treated, HRC56min;
precision ground, polished, hard
chromium plated

Body: Steel alloy, heat treated, zinc plated, chromate treated

Race: Steel alloy, heat treated, zinc plated, chromate treated

Sliding contact surfaces: Steel/Steel or Steel/PTFE Composite

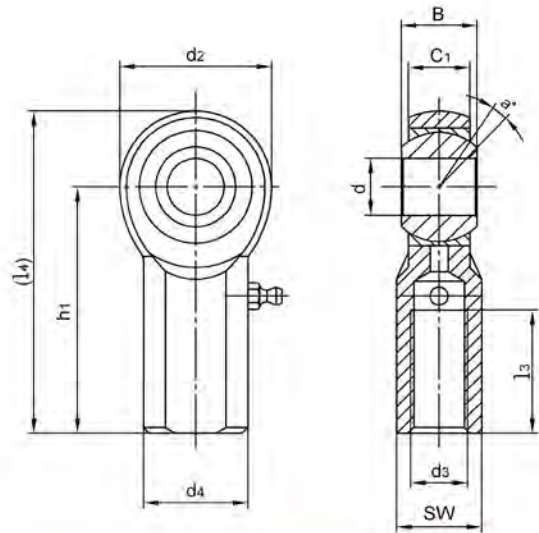

Bearing No.	Dimensions(mm/inches)										Ball dia	α° mis. angle	Load ratings (KN)	weight ≈ kg
	d ^{+0.038 -0.012}	B	C ₁	d ₂	d ₃ UNF-2B	h ₁	l ₃	(L ₄)	d ₄	SW				
JFX3	4.826	7.92	6.35	15.88	10-32	26.97	11.11	34.91	10.31	7.92	11.11	10	16.6	0.018
	0.1900	0.312	0.250	0.625		1.062	0.437	1.375	0.406	0.312	0.437			
JFX4	6.35	9.53	7.14	19.05	1/4-28	33.32	14.28	42.85	11.89	9.52	12.7	13	27.5	0.027
	0.2500	0.375	0.281	0.750		1.312	0.562	1.687	0.468	0.375	0.500			
JFX5	7.938	11.10	8.74	22.23	5/16-24	34.92	15.88	46.03	12.7	11.1	15.88	10	33.9	0.040
	0.3125	0.437	0.344	0.875		1.375	0.625	1.812	0.500	0.437	0.625			
JFX6	9.525	12.7	10.31	25.4	3/8-24	41.28	19.05	53.98	17.45	14.27	18.26	9	42.4	0.068
	0.3750	0.500	0.406	1.000		1.625	0.750	2.125	0.687	0.562	0.719			
JFX7	11.112	14.27	11.1	28.58	7/16-20	46.02	22.22	60.3	19.05	15.88	20.62	11	45.7	0.090
	0.4375	0.562	0.437	1.125		1.812	0.875	2.375	0.750	0.625	0.812			
JFX8	12.7	15.88	12.7	33.32	1/2-20	53.98	25.4	70.64	22.22	19.05	23.8	9	68.2	0.149
	0.5000	0.625	0.500	1.312		2.125	1.000	2.781	0.875	0.750	0.937			
JFX10	15.875	19.05	14.27	38.1	5/8-18	63.5	31.75	82.55	25.4	22.22	28.58	11	79.8	0.217
	0.6250	0.750	0.562	1.500		2.5	1.250	3.250	1.000	0.875	1.125			
JFX12	19.05	22.23	17.45	44.45	3/4-16	73.03	38.1	95.25	28.58	25.4	33.33	10	124.9	0.326
	0.7500	0.875	0.687	1.750		2.875	1.500	3.75	1.125	1.000	1.312			
JFX16	25.4	34.93	25.4	69.85	5/4-12	104.78	53.98	139.7	41.28	38.1	47.62	14	338.9	0.963
	1.0000	1.375	1.000	2.750		4.125	2.125	5.5	1.625	1.500	1.875			
JFX16-1**	25.4	34.93	25.4	69.85	1-14	104.78	53.98	139.7	41.28	38.1	47.62	14	338.9	1.093
	1.0000	1.375	1.000	2.750		4.125	2.125	5.5	1.625	1.500	1.875			

Notes: For grease fittings add "Z" to suffix. Example: JFX6Z
For studs add "Y" to suffix. Example: JFX5Y
For teflon liner add "T" to suffix. Example: JFX12T

Can supply rod ends with different pitch or accuracy of thread.

For left-hand thread, suffix "L" is added to bearing numbers. eg.: JFXL12T 3/4-16L

JMX.. JMX..T

Ball: Gcr15 Steel, heat treated, HRC56min;
precision ground, polished, hard
chromium plated

Body: Steel alloy, heat treated, zinc
plated, chromate treated

Race: Steel alloy, heat treated, zinc
plated, chromate treated

Sliding contact surfaces: Steel/Steel or
Steel/PTFE Composite

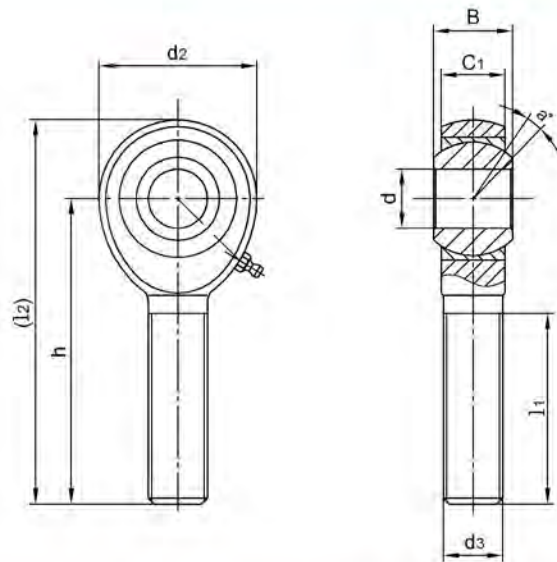

Bearing No.	Dimensions(mm/inches)								Ball dia	a° mis. angle	Load ratings (KN)	weight ≈ kg
	d ^{+0.038} / _{-0.012}	B	C1	d2	d3 UNF-2A	h	l1	(l2)				
JMX3	4.826	7.92	6.35	15.88	10-32	31.75	19.05	39.69	11.11	13	12.6	0.013
	0.1900	0.312	0.250	0.625		1.250	0.750	1.562	0.437			
JMX4	6.35	9.53	7.14	19.05	1/4-28	39.67	25.4	49.2	12.7	16	23.4	0.018
	0.2500	0.375	0.281	0.750		1.562	1.000	1.937	0.500			
JMX5	7.938	11.10	8.74	22.23	5/16-24	47.63	31.75	58.75	15.88	14	33.9	0.031
	0.3125	0.437	0.344	0.875		1.875	1.250	2.312	0.625			
JMX6	9.525	12.7	10.31	25.4	3/8-24	49.22	31.75	61.92	18.26	12	42.4	0.049
	0.3750	0.500	0.406	1.000		1.938	1.250	2.437	0.719			
JMX7	11.112	14.27	11.1	28.58	7/16-20	53.98	34.93	68.27	20.62	14	45.7	0.072
	0.4375	0.562	0.437	1.125		2.125	1.375	2.678	0.812			
JMX8	12.7	15.88	12.7	33.32	1/2-20	61.92	38.1	78.58	23.8	12	72.2	0.113
	0.5000	0.625	0.500	1.312		2.438	1.500	3.093	0.937			
JMX10	15.875	19.05	14.27	38.1	5/8-18	66.68	41.28	85.73	28.58	16	79.8	0.172
	0.6250	0.750	0.562	1.500		2.625	1.625	3.375	1.125			
JMX12	19.05	22.23	17.45	44.45	3/4-16	73.02	44.45	95.25	33.33	14	124.9	0.272
	0.7500	0.875	0.678	1.750		2.875	1.750	3.750	1.312			
JMX14	22.225	22.23	17.45	50.8	7/8-14	85.73	47.63	111.1	33.33	10	247.7	0.408
	0.8750	0.875	0.687	2.000		3.375	1.875	4.375	1.312			
JMX16	25.4	34.93	25.4	69.85	5/4-12	104.78	53.98	139.7	47.62	14	476.7	1.241
	1.0000	1.375	1.0000	2.750		4.125	2.125	5.500	1.875			
JMX16-1**	25.4	34.93	25.4	69.85	1-14	104.78	53.98	139.7	47.62	14	476.7	1.117
	1.0000	1.375	1.0000	2.750		4.125	2.125	5.500	1.875			

Notes: For grease fittings add "Z" to suffix. Example: JMX6Z
For studs add "Y" to suffix. Example: JMX5Y
For teflon liner add "T" to suffix. Example: JMX12T

Can supply rod ends with different pitch or accuracy of thread.

For left-hand thread, suffix "L" is added to bearing numbers. eg.: JMXL12T 3/4-16L

RJM..

Ball: Gcr15 Steel, heat treated, HRC56min;
 precision ground, polished, hard
 chromium plated
 Body: Carbon steel, decorative chrome plated
 Race: Steel alloy, heat treated, zinc plated, chromate treated
 Sliding contact surfaces: Steel/Steel

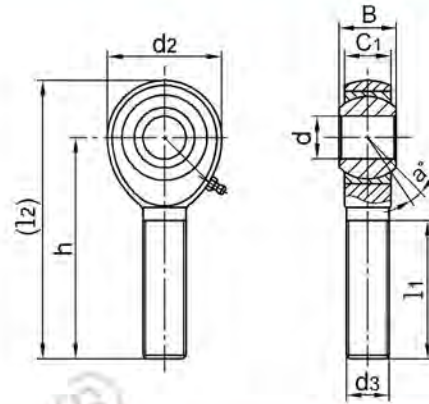

Bearing No.	Dimensions(mm/inches)									Ball dia	a° mis. angle	Load ratings (KN)	weight ≈ kg
	d ^{+0.038} / _{-0.012}	B	C ₁	d ₂	d ₃ UNF-2A	h	l ₁	(l ₂)					
RJM4	6.35	9.53	7.14	19.05	1/4-28	39.67	25.4	49.2	12.7	13	8.2	0.018	
	0.2500	0.375	0.281	0.750		1.562	1.000	1.937	0.500				
RJM5	7.938	11.10	8.74	22.23	5/16-24	47.63	31.75	58.75	15.88	10	11.1	0.031	
	0.3125	0.437	0.344	0.875		1.875	1.120	2.312	0.625				
RJM6	9.525	12.7	10.31	25.4	3/8-24	49.22	31.75	61.92	18.26	9	13.3	0.049	
	0.3750	0.500	0.406	1.000		1.938	1.250	2.437	0.719				

RJF..

Ball: Gcr15 Steel, heat treated, HRC56min;
 precision ground, polished,hard
 chromium plated
 Body: Carbon steel,decorative chrome plated
 Race: Steel alloy, heat treated, zinc plated, chromate treated
 Sliding contact surfaces: Steel/Steel

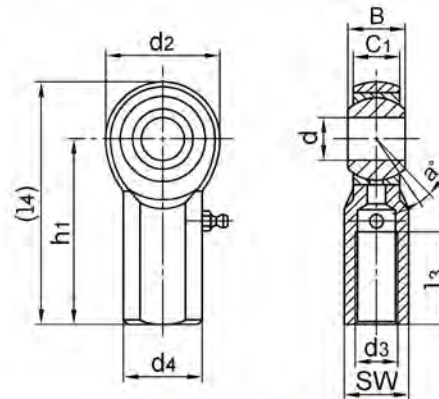

Bearing No.	Dimensions(mm/inches)										Ball dia	a° mis. angle	Load ratings (KN)	weight ≈ kg
	d ^{+0.038} / _{-0.012}	B	C ₁	d ₂	d ₃ UNF-2B	h ₁	l ₃	(l ₄)	d ₄	SW				
RJF4	6.35	9.53	7.14	19.05	1/4-28	33.32	14.85	42.85	11.89	9.53	12.7	13	9.0	0.027
	0.2500	0.375	0.281	0.750		1.312	0.562	1.687	0.468	0.375	0.500			
RJF5	7.938	11.10	8.74	22.23	5/16-24	34.92	15.88	46.03	12.7	11.1	15.88	10	11.1	0.040
	0.3125	0.437	0.344	0.875		1.312	0.625	1.812	0.500	0.437	0.625			
RJF6	9.525	12.7	10.31	25.4	3/8-24	41.28	19.05	53.98	17.45	14.27	18.26	9	13.3	0.068
	0.3750	0.500	0.406	1.000		1.625	0.750	2.125	0.687	0.562	0.719			

Can supply rod ends with different pitch or accuracy of thread.
 For left-hand thread, suffix"L" is added to bearing numbers. eg.: RJML6 3/4-24L; RJFL6 3/8-24L

RJMX..T

Ball: Gcr15 Steel, heat treated, HRC56min;
precision ground, polished, hard
chromium plated

Body: Steel alloy, heat treated, bright electroless
nickel or hard chrome plated

Race: Steel alloy, heat treated, zinc
plated, chromate treated

Liner: PTFE Composite or PTFE fabric

Sliding contact surfaces: Steel/PTFE Composite

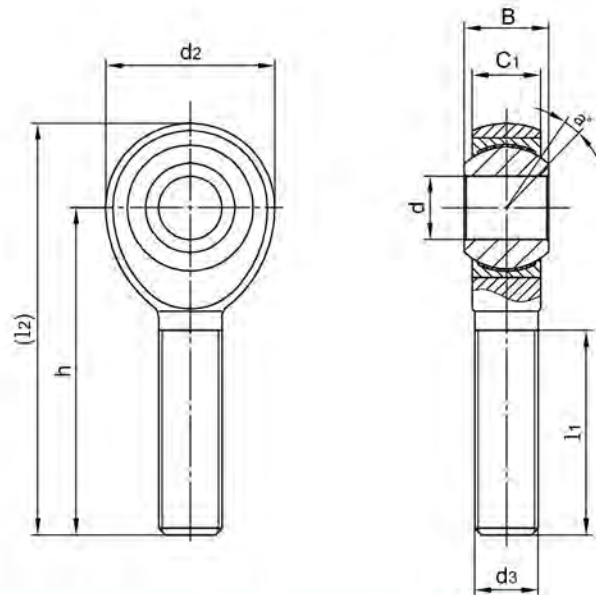

Bearing No.	Dimensions(mm/inches)								Ball dia	a° mis. angle	Load ratings (KN)	weight ≈ kg
	d ^{+0.038 -0.012}	B	C1	d2	d3 UNF-2A	h	l1	(l2)				
RJMX6T	9.525	12.7	10.31	25.4	3/8-24	49.22	31.75	61.92	18.26	12	42.4	0.035
	0.3750	0.500	0.406	1.000		1.938	1.250	2.437	0.719			
RJMX7T	11.112	14.27	11.1	28.58	7/16-20	53.98	34.93	68.27	20.62	14	45.7	0.041
	0.4375	0.562	0.437	1.125		2.125	1.375	2.678	0.812			
RJMX8T	12.7	15.88	12.7	33.32	1/2-20	61.92	38.1	78.58	23.8	12	72.2	0.063
	0.5000	0.625	0.500	1.312		2.438	1.500	3.093	0.937			
RJMX10T	15.875	19.05	14.27	38.1	5/8-18	66.68	41.28	85.73	28.58	16	79.8	0.108
	0.6250	0.750	0.562	1.500		2.625	1.625	3.375	1.125			
RJMX12T	19.05	22.23	17.45	44.45	3/4-16	73.02	44.45	95.25	33.33	14	124.9	0.136
	0.7500	0.875	0.687	1.750		2.875	1.750	3.750	1.312			

Can supply rod ends with different pitch or accuracy of thread.

For left-hand thread, suffix "L" is added to bearing numbers. eg.: RJMXL6T 3/8-24L

RRSMX..T

Ball: Gcr15 Steel, heat treated, HRC56min,
precision ground, polished, hard
chromium plated

Body: Steel alloy, heat treated, bright electroless
nickel or hard chrome plated

Race: Steel alloy, heat treated,
zinc plated, chromate treated

Liner: PTFE composite or PTFE fabric

Sliding contact surfaces: Steel/PTFE liner

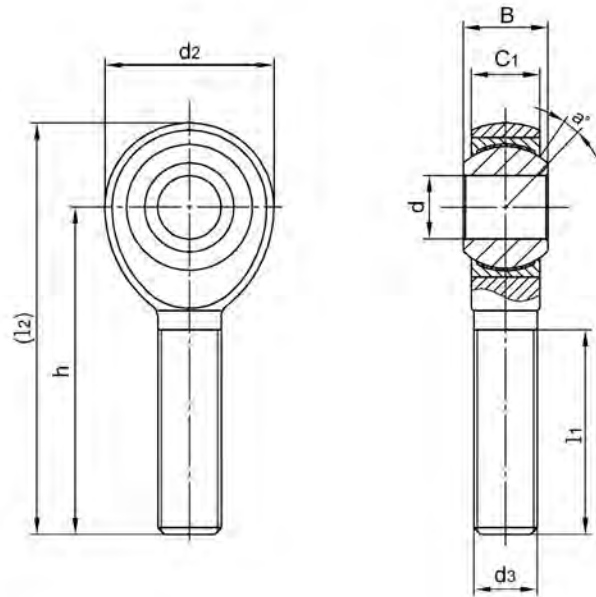

Bearing No.	Dimensions(mm/inches)								Ball dia	a° mis. angle	Load ratings (KN)	weight ≈ kg
	d ^{+0.038 -0.012}	B	C ₁	d ₂	d ₃ UNF-2A	h	l ₁	(l ₂)				
RRSMX6T	9.525	12.7	10.31	28.58	7/16-20	53.98	34.93	68.27	18.26	12	78.3	0.072
	0.3750	0.500	0.406	1.125		2.125	1.375	2.687	0.719			
RRSMX7T	11.112	14.27	11.1	33.32	1/2-20	61.92	38.1	78.58	20.62	14	104.3	0.112
	0.4375	0.562	0.437	1.312		2.438	1.500	3.093	0.812			
RRSMX8T	12.7	15.88	12.7	38.1	5/8-18	66.68	41.28	85.73	23.8	12	139.7	0.173
	0.5000	0.625	0.5000	1.500		2.625	1.625	3.375	0.937			
RRSMX10T	15.875	19.05	14.27	44.45	3/4-16	73.03	44.45	95.25	28.58	16	180.5	0.273
	0.6250	0.750	0.562	1.750		2.875	1.750	3.75	1.125			

Can supply rod ends with different pitch or accuracy of thread.

For left-hand thread, suffix "L" is added to bearing numbers. eg.: RRSMXL6T 7/16-20L

SJF..T

Ball: 440C Stainless steel, heat treated, HRC56 min,

precision ground, polished

Body: 17-4Ph Stainless steel, heat treated

Race: 17-4Ph Stainless steel, heat treated

Sliding contact surfaces: Steel/PTFE composite

or Steel/PTFE fabric

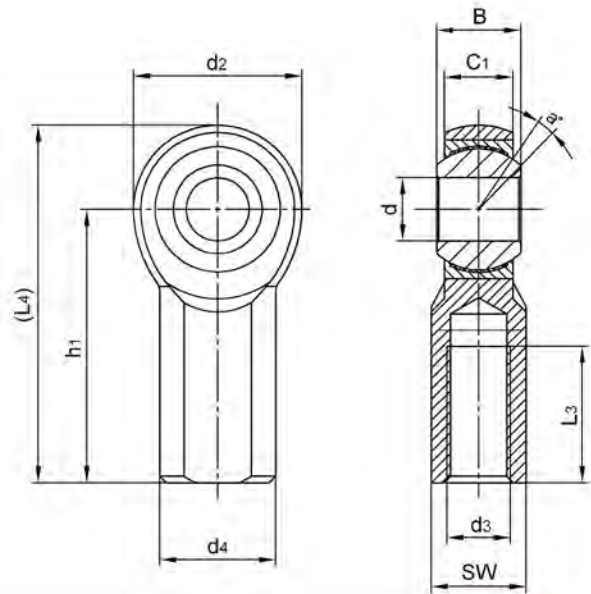

Bearing No.	Dimensions(mm/inches)										Ball dia	a° mis. angle	Load ratings (KN)	weight ≈ kg
	d ^{+0.038 -0.012}	B	C ₁	d ₂	d ₃ UNF-2B	h ₁	l ₁	(l ₂)	d ₄	SW				
SJF4T	6.35	9.53	7.14	20.47	1/4-28	33.32	15.88	43.55	11.89	9.52	13.48	16	21.3	0.026
	0.2500	0.375	0.281	0.806		1.312	0.625	1.714	0.468	0.375	0.531			
SJF5T	7.938	11.11	8.74	22.86	5/16-24	34.93	17.45	46.35	12.7	11.1	15.06	14	26.3	0.041
	0.3125	0.437	0.344	0.900		1.375	0.687	1.825	0.500	0.437	0.593			
SJF6T	9.525	12.7	10.31	26.03	3/8-24	41.28	22.22	54.29	17.45	14.27	17.45	12	32.7	0.068
	0.3750	0.500	0.406	1.025		1.625	0.875	2.13	0.687	0.562	0.687			
SJF7T	11.112	14.27	11.1	29.21	7/16-20	46.02	25.4	60.6	19.05	15.88	19.83	14	35.2	0.089
	0.4375	0.562	0.437	1.150		1.812	1.000	2.38	0.750	0.625	0.781			
SJF8T	12.7	15.88	12.7	33.96	1/2-20	53.98	28.58	70.96	22.22	19.05	22.22	12	55.7	0.149
	0.5000	0.625	0.500	1.337		2.125	1.125	2.97	0.875	0.750	0.875			
SJF10T	15.875	19.05	17.27	38.74	5/8-18	63.5	34.93	82.87	25.4	22.22	26.97	16	61.6	0.216
	0.6250	0.750	0.562	1.525		2.500	1.375	3.262	1.000	0.875	1.062			
SJF12T	19.05	22.23	17.45	45.09	3/4-16	73.03	41.28	95.57	28.58	25.4	31.75	14	96.3	0.327
	0.7500	0.875	0.687	1.775		2.875	1.625	3.762	1.125	1.000	1.250			

Can supply rod ends with different pitch or accuracy of thread.

For left-hand thread, suffix"L" is added to bearing numbers. eg.: SJFL6T 3/8-24L

SJM..T

Ball: 440C Stainless steel, heat treated HRC56 min,
precision ground, polished

Body: 17-4Ph Stainless steel, heat treated

Race: 17-4Ph Stainless steel, heat treated

Liner: PTFE composite or PTFE fabric

Sliding contact surfaces: Steel/PTFE composite
or Steel/PTFE fabric

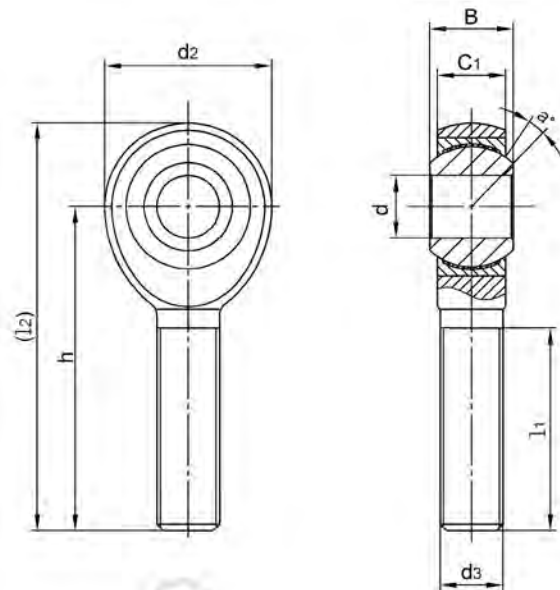

Bearing No.	Dimensions(inches)								Ball dia	α° mis. angle	Load ratings (ibs)	weight ≈ kg
	d ^{+0.0001/-0.0005}	B ^{+0.000/-0.002}	C1 ^{+0.005/-0.005}	d2 ^{+0.010/-0.010}	d3	h ^{+0.010/-0.010}	l1 ^{+0.031/-0.031}	l2				
SJM4T	0.2500	0.437	0.337	0.806	1/4-28	1.562	0.968	1.964	0.531	16	4874	0.032
SJM5T	0.3125	0.437	0.327	0.900	5/16-24	1.875	1.187	2.325	0.593	14	7196	0.039
SJM6T	0.3750	0.500	0.416	1.025	3/8-24	1.938	1.187	2.450	0.687	12	8580	0.061
SJM7T	0.4375	0.562	0.452	1.150	7/16-20	2.125	1.281	2.700	0.781	14	12000	0.083
SJM8T	0.5000	0.625	0.515	1.337	1/2-20	2.438	1.468	3.106	0.875	12	19520	0.126
SJM10T	0.6250	0.750	0.577	1.525	5/8-18	2.625	1.562	3.387	1.062	16	21920	0.192
SJM12T	0.7500	0.875	0.640	1.775	3/4-16	2.875	1.687	3.762	1.250	14	29310	0.289

Can supply rod ends with different pitch or accuracy of thread.

For left-hand thread, suffix "L" is added to bearing numbers. eg.: SJML6T 3/8-24L

SRSMX..T

Ball: 440C Stainless steel, heat treated, HRC56 min,
precision ground, polished

Body: 17-4Ph Stainless steel, heat treated

Race: 17-4Ph Stainless steel, heat treated

Liner: PTFE composite or PTFE fabric

Sliding contact surfaces: Steel/PTFE composite
or Steel/PTFE fabric

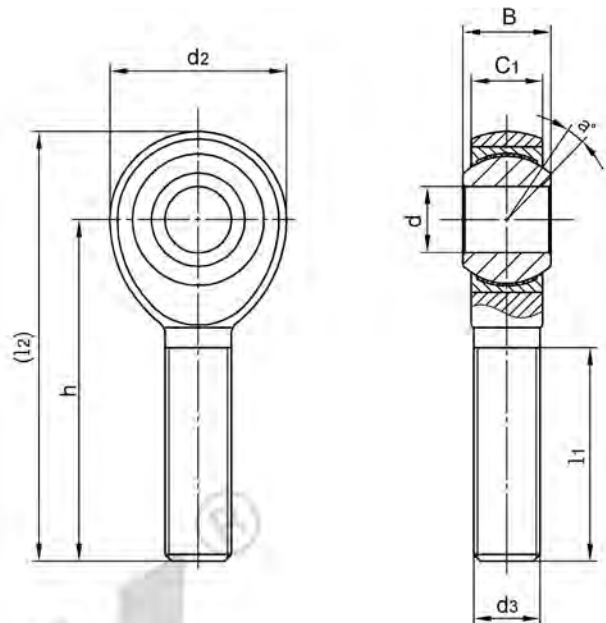

SRSM-T:STAINLESS STEEL EXTRA HEAVY DUTY SHANK

Bearing No.	Dimensions(inches)								Ball dia	a° mis. angle	Load ratings (KN)	weight ≈ kg
	d ^{+0.0000/-0.0005}	B ^{+0.000/-0.002}	C1 ^{+0.005/-0.005}	d2 ^{+0.010/-0.010}	d3 _{UNF-3A}	h ^{+0.010/-0.010}	l1 ^{+0.031/-0.031}	(l2)				
SRSMX6T	0.3750	0.500	0.416	1.150	7/16-20	2.125	1.375	2.450	0.687	11	17610	0.072
SRSMX7T	0.4375	0.562	0.452	1.150	1/2-20	2.125	1.75	2.700	0.781	13	23470	0.112
SRSMX8T	0.500	0.625	0.515	1.337	5/8-18	2.438	1.625	3.106	0.875	12	33172	0.173
SRSMX10T	0.6250	0.750	0.577	1.525	3/4-16	2.625	1.75	3.387	1.062	14	40507	0.273

Can supply rod ends with different pitch or accuracy of thread.

For left-hand thread, suffix"L" is added to bearing numbers. eg.: SRSMXL6T 7/16-20L

HJMX..T

Ball: Gcr15 Steel, heat treated, HRC56min;
 precision ground, polished, hard
 chromium plated

Body: 4340 steel, heat treated,
 zinc plated, chromate treated

Race: Steel alloy, zinc plated, chromate treated

Liner: PTFE composite or PTFE fabric

Sliding contact surfaces: Steel/PTFE Composite
 or Steel/PTFE fabric

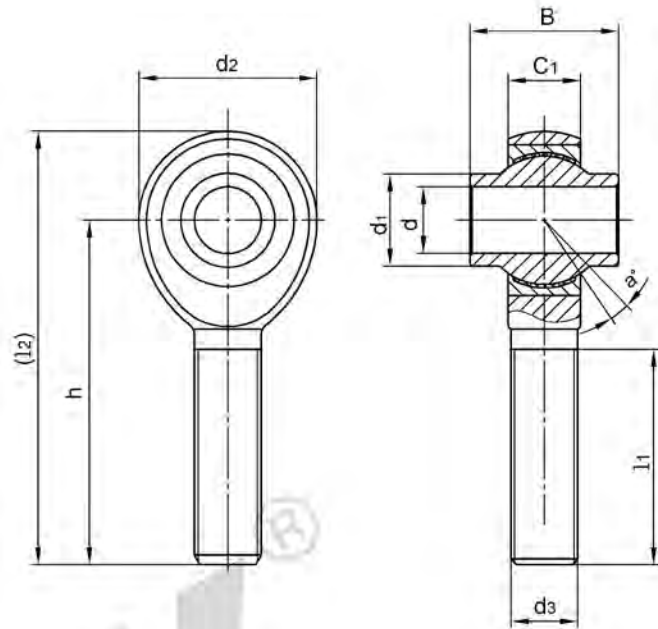

Bearing No.	Dimensions(inches)									Ball dia	a° mis. angle	Load ratings (KN)	weight ≈ kg
	d ^{+0.0000} _{-0.0005}	B ^{+0.000} _{-0.002}	C1 ^{+0.005} _{-0.005}	d2 ^{+0.010} _{-0.010}	d3 _{UNF-3A}	h ^{+0.015} _{-0.015}	l1 ^{+0.031} _{-0.031}	(l2)	d1				
HJMX6T	0.3750	0.813	0.355	1.150	3/8-24	2.125	1.281	2.70	0.512	0.781	21	50.6	0.054
HJMX7T	0.4375	0.875	0.355	1.337	7/16-20	2.438	1.468	3.10	0.618	0.875	21	69.9	0.104
HJMX8T	0.5000	0.937	0.411	1.525	1/2-20	2.625	1.562	3.38	0.730	1.000	18	105.4	0.149
HJMX10T	0.6250	1.200	0.577	1.775	5/8-18	2.875	1.678	3.72	0.856	1.250	19	125	0.258
HJMX12T	0.7500	1.280	0.630	2.025	3/4-16	3.375	2.000	4.38	0.970	1.375	17	172.2	0.371

Can supply rod ends with different pitch or accuracy of thread.

For left-hand thread, suffix"L" is added to bearing numbers. eg.: HJMXL6T 3/8-24L

HRSMX..T

Ball: Gcr15 Steel, heat treated, HRC56min;
precision ground polished, hard
chromium plated

Body: 4340 steel, heat treated,
zinc plated, chromate treated

Race: Steel alloy, zinc plated, chromate treated

Liner: PTFE composite or PTFE fabric

Sliding contact surfaces: Steel/PTFE Composite
or Steel/PTFE fabric

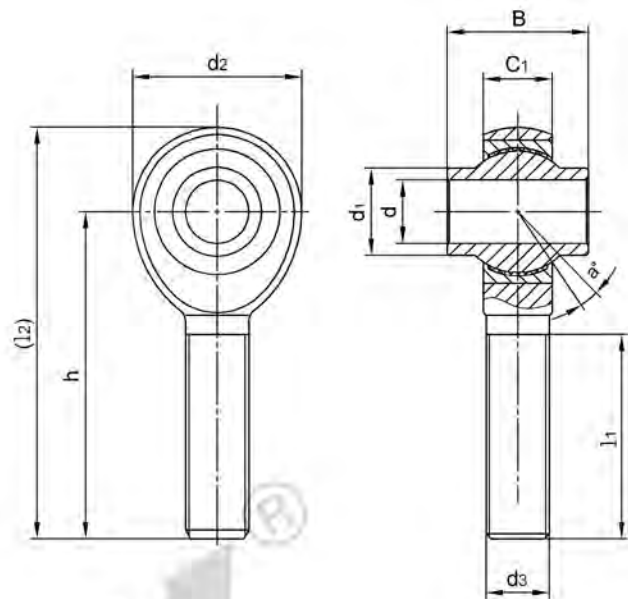

Bearing No.	Dimensions(inches)									Ball dia	a° mis. angle	Load ratings (KN)	weight ≈ kg
	d ^{+0.008} / _{-0.012}	B	C ₁	d ₂	d ₃ _{UNF-2A}	h	l ₁	(l ₂)	d ₁				
HRSMX6T	0.3750	0.813	0.355	1.150	3/8-24	2.125	1.281	2.70	0.512	0.781	21	52.4	0.054
HRSMX7T	0.4375	0.875	0.355	1.337	7/16-20	2.438	1.468	3.10	0.618	0.875	21	76	0.104
HRSMX8T	0.5000	0.937	0.411	1.525	1/2-20	2.625	1.562	3.38	0.730	1.000	18	105.4	0.149
HRSMX10T	0.6250	1.200	0.577	1.775	5/8-18	2.875	1.678	3.72	0.856	1.250	19	142.7	0.258
HRSMX12T	0.7500	1.280	0.630	2.025	3/4-16	3.375	2.000	4.38	0.970	1.375	17	172.2	0.371

Can supply rod ends with different pitch or accuracy of thread.

For left-hand thread, suffix"L" is added to bearing numbers. eg.: HRSMXL6T 3/8-24L



RSM.. RSM..T

Ball: Gcr15 Steel, heat treated, HRC56min;
precision ground, polished hard
chromium plated

Body: carbon steel Zinc plated,chromate treated

Race: Steel alloy, heat treated
zinc plated, chromate treated

Sliding contact surfaces: Steel/Steel or Steel/PTFE composite

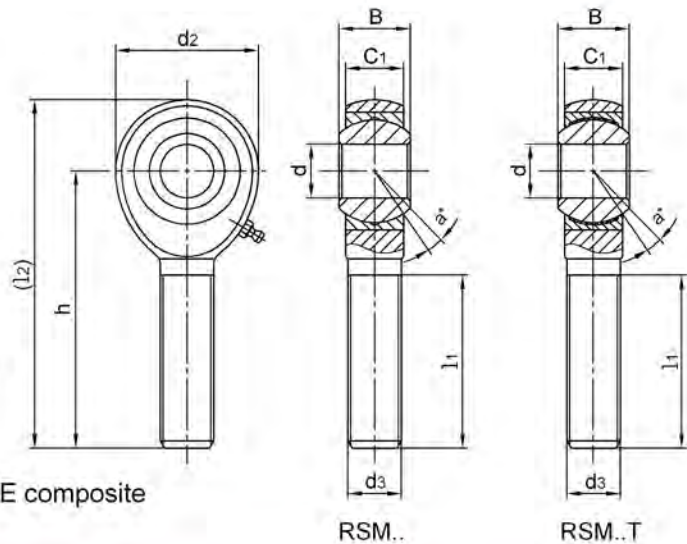

Bearing No.	Dimensions(mm/inches)								Ball dia	a° mis. angle	Load ratings (KN)	weight ~ kg
	d ^{+0.038 -0.012}	B	C1	d2	d3 UNF-2A	h	l1	(l2)				
RSM3	4.826	7.92	6.35	19.05	1/4-28	39.67	25.4	49.2	11.11	10	4.4	0.019
RSM3T	0.1900	0.312	0.250	0.750		1.562	1.000	1.938	0.437			
RSM4	6.35	9.53	7.14	22.23	5/16-24	47.63	31.75	58.75	12.7	13	8.2	0.032
RSM4T	0.2500	0.375	0.281	0.875		1.875	1.250	2.312	0.500			
RSM5	7.938	11.10	8.74	25.4	3/8-24	49.22	31.75	61.92	15.88	12	11.1	0.050
RSM5T	0.3125	0.437	0.344	1.000		1.938	1.250	2.437	0.625			
RSM6Z	9.525	12.7	10.31	28.58	7/16-20	53.98	34.93	68.27	18.26	10	13.3	0.072
RSM6T	0.3750	0.500	0.406	1.125		2.125	1.375	2.688	0.719			
RSM7Z	11.112	14.27	11.1	33.32	1/2-20	61.92	38.1	78.58	20.62	12	18.5	0.113
RSM7T	0.4375	0.562	0.437	1.312		2.438	1.500	3.093	0.812			
RSM8Z	12.7	15.88	12.7	38.1	5/8-18	66.68	41.25	85.73	23.8	10	29.1	0.173
RSM8T	0.5000	0.625	0.500	1.500		2.625	1.625	3.375	0.937			
RSM10Z	15.875	19.05	14.27	44.45	3/4-16	73.02	44.45	95.25	28.58	13	31.2	0.273
RSM10T	0.6250	0.750	0.562	1.750		2.875	1.750	3.750	1.125			

Notes:

For grease fittings add " Z" to suffix,example: RSM6Z

For teflon liner add " T" to suffix,example: RSM10T

Can supply rod ends with different pitch or accuracy of thread.

For left-hand thread, suffix"L" is added to bearing numbers. eg.: RSML6 7/16-20L

For RSM3,RSM4,RSM5,zerk grease fitting is not available.

**RSMX..
RSMX..T**

Ball: Gcr15 Steel, heat treated, HRC56min;
 precision ground, polished, hard chromium plated
 Body: Steel alloy, heat treated, zinc plated,
 chromate treated
 Race: Steel alloy, heat treated, zinc plated, chromate treated
 Liner: PTFE Composite
 Sliding contact surfaces: Steel/Steel or Steel/PTFE composite

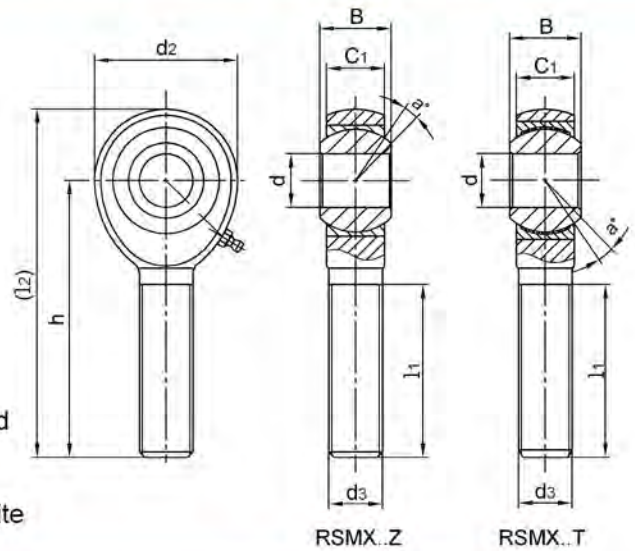

Bearing No.	Dimensions(mm/inches)								Ball dia	a° mis. angle	Load ratings (KN)	weight ≈ kg
	d ^{+0.005 -0.013}	B	C ₁	d ₂	d ₃ UNF-2A	h	l ₁	(l ₂)				
RSMX3	4.826	7.92	6.35	19.05	1/4-28	39.67	25.4	49.2	11.11	10	23.4	0.019
RSMX3T	0.1900	0.312	0.250	0.750		1.562	1.000	1.937	0.437			
RSMX4	6.35	9.53	7.14	22.23	5/16-24	47.63	31.75	58.75	12.7	13	37.6	0.032
RSMX4T	0.2500	0.375	0.281	0.875		1.875	1.250	2.312	0.500			
RSMX5	7.938	11.10	8.74	25.4	3/8-24	49.22	31.75	61.92	15.88	10	57.8	0.050
RSMX5T	0.3125	0.437	0.344	1.000		1.938	1.250	2.437	0.625			
RSMX6Z	9.525	12.7	10.31	28.58	7/16-20	53.98	34.93	68.27	18.26	9	78.3	0.072
RSMX6T	0.3750	0.500	0.406	1.125		2.125	1.375	2.687	0.719			
RSMX7Z	11.112	14.27	11.1	33.32	1/2-20	61.92	38.1	78.58	20.62	11	104.3	0.112
RSMX7T	0.4375	0.562	0.437	1.312		2.438	1.500	3.093	0.812			
RSMX8Z	12.7	15.88	12.7	38.1	5/8-18	66.68	41.28	85.73	23.8	9	139.7	0.173
RSMX8T	0.5000	0.625	0.500	1.500		2.625	1.625	3.375	0.937			
RSMX10Z	15.875	19.05	14.27	44.45	3/4-16	73.03	44.45	95.25	28.58	11	180.5	0.273
RSMX10T	0.6250	0.750	0.562	1.75		2.875	1.750	3.75	1.125			
RSMX12Z	19.05	22.23	17.45	50.8	3/8-14	85.73	47.63	111.1	33.33	10	247.7	0.416
RSMX12T	0.7500	0.875	0.687	2.000		3.375	1.875	4.375	1.312			
RSMX14Z	22.225	22.23	19.43	58.72	1-14	96.52	60.33	125.88	33.33	5	280.6	0.590
RSMX14T	0.8750	0.8750	0.765	2.312		3.8	2.375	4.955	1.312			

Notes:
 For grease fittings add " Z" to suffix , example: RSMX6Z
 For teflon liner add " T" to suffix , example: RSMX12T
 Can supply rod ends with different pitch or accuracy of thread.
 For RSMX3,RSMX4,RSMX5,zerk grease fitting is not available.

NXF..

Ball: Gcr15 Steel, heat treated, HRC56min;

precision ground, polished,hard

chromium plated

Body: Alloy steel heat treated; zinc plated;

Race: Nylon polymer with PTFE additive

Sliding contact surfaces: Steel/Nylon

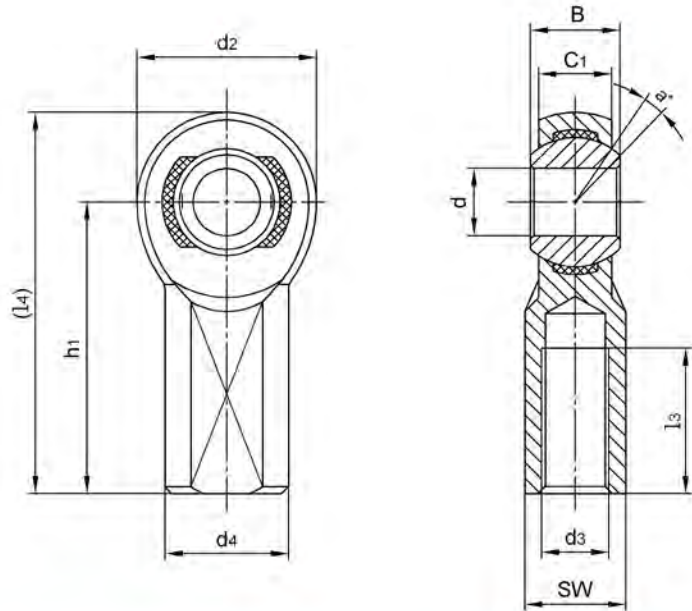

Bearing No.	Dimensions(mm/inches)										Ball dia	a° mis. angle	Load ratings (KN)	weight ≈ kg
	d ^{+0.036 -0.012}	B	C ₁	d ₂	d ₃ UNF-2B	h ₁	l ₃	(l ₄)	d ₄	SW				
NXF3	4.826	7.92	6.35	15.88	10-32	26.97	11.11	34.91	10.31	7.92	11.11	10	16.6	0.018
	0.1900	0.312	0.250	0.625		1.062	0.437	1.375	0.406	0.312	0.437			
NXF4	6.35	9.53	7.14	19.05	1/4-28	33.32	14.27	42.85	11.89	9.52	12.7	13	27.5	0.027
	0.2500	0.375	0.281	0.750		1.312	0.562	1.687	0.468	0.375	0.500			
NXF5	7.938	11.10	8.74	22.23	5/16-24	34.92	15.88	46.03	12.7	11.1	15.88	10	33.9	0.040
	0.3125	0.437	0.344	0.875		1.375	0.625	1.812	0.500	0.437	0.625			
NXF6	9.525	12.7	10.31	25.4	3/8-24	41.28	19.05	53.98	17.45	14.27	18.26	9	42.4	0.063
	0.3750	0.500	0.406	1.000		1.625	0.75	2.125	0.687	0.562	0.719			
NXF7	11.11	14.27	11.1	28.58	7/16-20	46.02	22.22	60.31	19.05	15.88	20.62	11	45.7	0.086
	0.4375	0.562	0.437	1.125		1.812	0.875	2.375	0.750	0.625	0.812			
NXF8	12.7	15.88	12.7	33.32	1/2-20	53.98	25.4	70.64	22.22	19.05	23.8	9	72.2	0.140
	0.5000	0.625	0.500	1.312		2.125	1.000	2.781	0.875	0.750	0.937			
NXF10	15.875	19.05	14.27	38.1	5/8-18	63.5	31.75	82.55	25.4	22.23	28.58	11	79.8	0.204
	0.6250	0.750	0.562	1.500		2.5	1.250	3.250	1.000	0.875	1.125			
NXF12	19.05	22.23	17.45	44.45	3/4-16	73.02	38.1	95.25	28.58	25.4	33.33	10	124.9	0.313
	0.7500	0.875	0.687	1.750		2.875	1.500	3.750	1.125	1.000	1.312			

Can supply rod ends with different pitch or accuracy of thread.

For left-hand thread, suffix "L" is added to bearing numbers. eg.: NXFL12 3/4-16L



NXM..

Ball: Gcr15 Steel, heat treated, HRC56min;
 precision ground, polished, hard
 chromium plated

Body: Alloy steel heat treated; zinc plated;

Race: Nylon polymer with PTFE additive

Sliding contact surfaces: Steel/Nylon

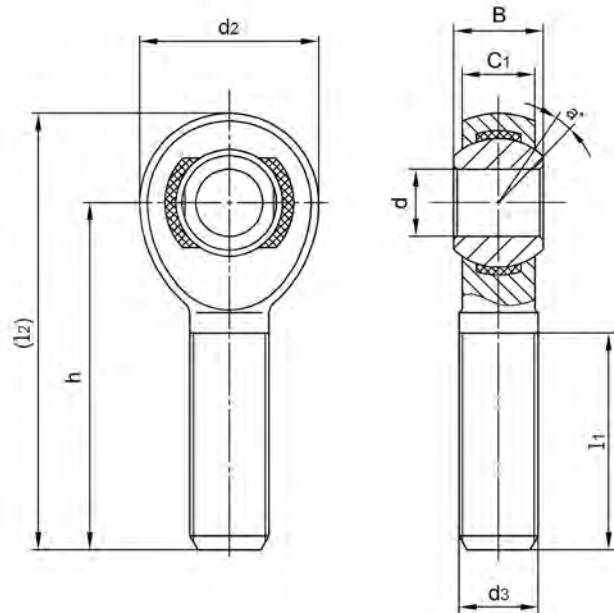

Bearing No.	Dimensions(mm/inches)								Ball dia	a° mis. angle	Load ratings (KN)	weight ≈ g
	d ^{+0.038} / _{-0.012}	B	C ₁	d ₂	d ₃ UNF-2A	h	l ₁	(l ₂)				
NXM3	4.826	7.92	6.35	15.88	10-32	31.75	19.05	39.69	11.11	10	12.6	0.013
	0.1900	0.312	0.250	0.625		1.250	0.750	1.562	0.437			
NXM4	6.35	9.53	7.14	19.05	1/4-28	39.67	25.4	49.2	12.7	13	23.3	0.018
	0.2500	0.375	0.281	0.750		1.562	1.000	1.937	0.500			
NXM5	7.938	11.10	8.74	22.23	5/16-24	47.63	31.75	58.75	15.88	10	33.9	0.031
	0.3125	0.437	0.344	0.875		1.875	1.250	2.312	0.625			
NXM6	9.525	12.7	10.31	25.4	3/8-24	49.22	31.75	61.92	18.26	9	42.4	0.049
	0.3750	0.500	0.406	1.000		1.938	1.250	2.687	0.719			
NXM7	11.112	14.27	11.1	28.58	7/16-20	53.98	34.93	68.27	20.62	11	45.7	0.068
	0.4375	0.562	0.437	1.125		2.125	1.375	2.678	0.812			
NXM8	12.7	15.88	12.7	33.32	1/2-20	61.92	38.1	78.58	23.8	9	72.2	0.108
	0.5000	0.625	0.500	1.312		2.438	1.500	3.093	0.937			
NXM10	15.875	19.05	14.27	38.1	5/8-18	66.68	41.28	85.73	28.58	11	79.8	0.163
	0.6250	0.750	0.562	1.500		2.625	1.625	3.375	1.125			
NXM12	19.05	22.23	17.45	44.45	3/4-16	73.02	44.45	95.25	33.33	10	124.9	0.258
	0.7500	0.875	0.687	1.750		2.875	1.750	3.750	1.312			

Can supply rod ends with different pitch or accuracy of thread.
 For left-hand thread, suffix "L" is added to bearing numbers. eg.: NXML12 3/4-16L

NEXF..

Ball: Gcr15 Steel, heat treated, HRC56min;
 precision ground, polished, hard
 chromium plated

Body: Carbon steel, zinc plated, chromate treated

Race: Nylon polymer with PTFE additive

Sliding contact surfaces: Steel/Nylon

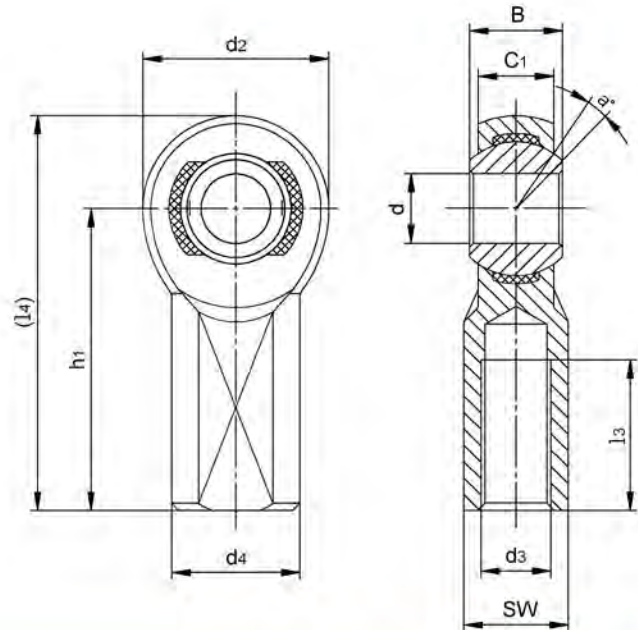

Bearing No.	Dimensions(mm/inches)										Ball dia	a° mis. angle	Load ratings (KN)	weight ≈ kg
	d ^{+0.038} _{-0.012}	B	C ₁	d ₂	d ₃ _{UNF-2B}	h ₁	l ₃	(L ₄)	d ₄	SW				
NEXF3	4.826	7.92	6.35	15.88	10-32	26.97	11.11	34.91	10.31	7.92	11.11	10	6.8	0.018
	0.1900	0.312	0.250	0.625		1.062	0.437	1.375	0.406	0.312	0.437			
NEXF4	6.35	9.53	7.14	19.05	1/4-28	33.32	14.27	42.85	11.89	9.52	12.7	13	11.2	0.027
	0.2500	0.375	0.281	0.750		1.312	0.562	1.687	0.468	0.375	0.500			
NEXF5	7.938	11.10	8.74	22.23	5/16-24	34.92	15.88	46.03	12.7	11.1	15.88	10	13.9	0.040
	0.3125	0.437	0.344	0.875		1.375	0.625	1.812	0.500	0.437	0.625			
NEXF6	9.525	12.7	10.31	25.4	3/8-24	41.28	19.05	53.98	17.45	14.27	18.26	9	17.4	0.063
	0.3750	0.500	0.406	1.000		1.625	0.75	2.125	0.687	0.562	0.719			
NEXF7	11.11	14.27	11.1	28.58	7/16-20	46.02	22.22	60.31	19.05	15.88	20.62	11	18.7	0.086
	0.4375	0.562	0.437	1.125		1.812	0.875	2.375	0.750	0.625	0.812			
NEXF8	12.7	15.88	12.7	33.32	1/2-20	53.98	25.4	70.64	22.22	19.05	23.8	9	29.6	0.140
	0.5000	0.625	0.500	1.312		2.125	1.000	2.781	0.875	0.750	0.937			
NEXF10	15.875	19.05	14.27	38.1	5/8-18	63.5	31.75	82.55	25.4	22.23	28.58	11	32.7	0.204
	0.6250	0.750	0.562	1.500		2.5	1.250	3.250	1.000	0.875	1.125			
NEXF12	19.05	22.23	17.45	44.45	3/4-16	73.02	38.1	95.25	28.58	25.4	33.33	10	51.2	0.313
	0.7500	0.875	0.687	1.750		2.875	1.500	3.750	1.125	1.000	1.312			

Can supply rod ends with different pitch or accuracy of thread.

For left-hand thread, suffix "L" is added to bearing numbers. eg.: NEXFL12 3/4-16L

NEXM..

Ball: Gcr15 Steel, heat treated, HRC56min;
 precision ground, polished, hard
 chromium plated

Body: Carbon steel, zinc plated, chromate treated

Race: Nylon polymer with PTFE additive

Sliding contact surfaces: Steel/Nylon

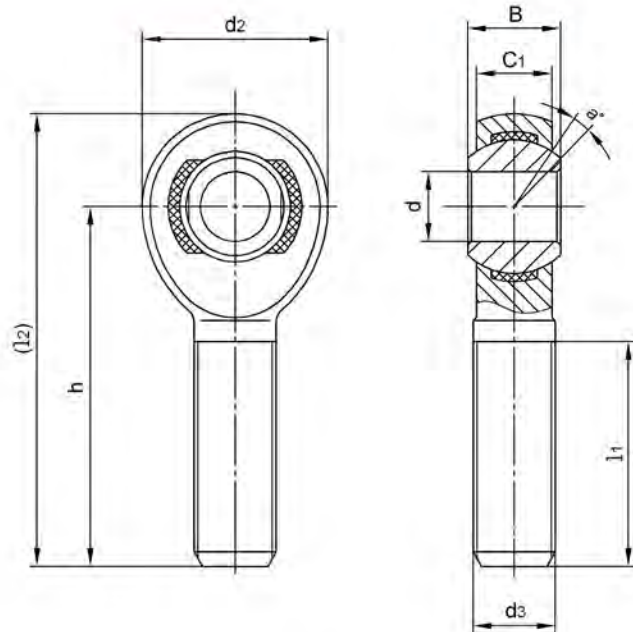

Bearing No.	Dimensions(mm/inches)								Ball dia	a° mis. angle	Load ratings (KN)	weight ≈ kg
	d	B	C1	d2	d3 UNF-2A	h	l1	(l2)				
NEXM3	4.826	7.92	6.35	15.88	10-32	31.75	19.05	39.69	11.11	10	4.4	0.013
	0.1900	0.312	0.250	0.625		1.250	0.750	1.562	0.437			
NEXM4	6.35	9.53	7.14	19.05	1/4-28	39.67	25.4	49.2	12.7	13	8.2	0.018
	0.2500	0.375	0.281	0.750		1.562	1.000	1.937	0.500			
NEXM5	7.938	11.10	8.74	22.23	5/16-24	47.63	31.75	58.75	15.88	10	12.3	0.031
	0.3125	0.437	0.344	0.875		1.875	1.250	2.312	0.625			
NEXM6	9.525	12.7	10.31	25.4	3/8-24	49.22	31.75	61.92	18.26	9	17.4	0.049
	0.3750	0.500	0.406	1.000		1.938	1.250	2.687	0.719			
NEXM7	11.112	14.27	11.1	28.58	7/16-20	53.98	34.93	68.27	20.62	11	18.7	0.068
	0.4375	0.562	0.437	1.125		2.125	1.375	2.678	0.812			
NEXM8	12.7	15.88	12.7	33.32	1/2-20	61.92	38.1	78.58	23.8	9	29.6	0.108
	0.5000	0.625	0.500	1.312		2.438	1.500	3.093	0.937			
NEXM10	15.875	19.05	14.27	38.1	5/8-18	66.68	41.28	85.73	28.58	11	32.7	0.163
	0.6250	0.750	0.562	1.500		2.625	1.625	3.375	1.125			
NEXM12	19.05	22.23	17.45	44.45	3/4-16	73.02	44.45	95.25	33.33	10	51.2	0.258
	0.7500	0.875	0.687	1.750		2.875	1.750	3.750	1.312			

Can supply rod ends with different pitch or accuracy of thread.

For left-hand thread, suffix"L" is added to bearing numbers. eg.: NEXML12 3/4-16L

NJF..

- Ball: Gcr15 Steel, heat treated, HRC56min;
precision ground, polished, hard
chromium plated
- Body: Carbon steel, zinc plated, chromate treated
- Race: PTFE lubricated, fiber reinforced
Engineering plastic
- Sliding contact surfaces: Steel/engineering plastic

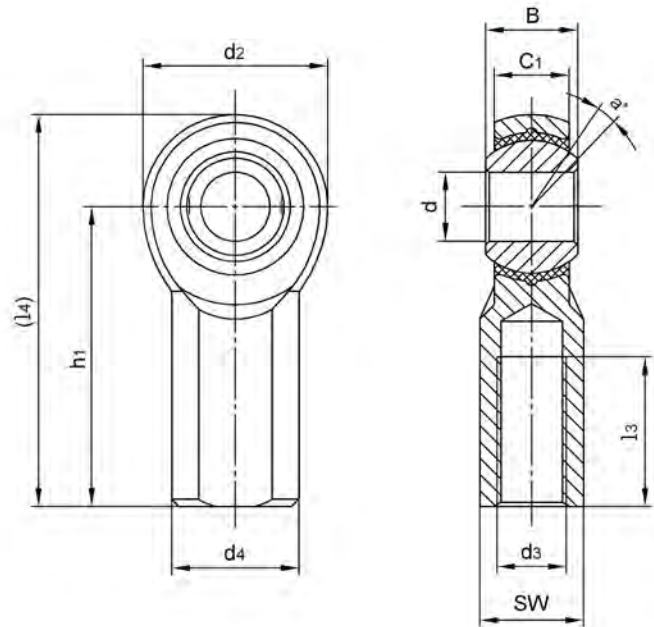

Bearing No.	Dimensions(mm/inches)										Ball dia	a° mis. angle	Load ratings (KN)	weight ≈ kg
	d	B	C ₁	d ₂	d ₃ UNF-2B	h ₁	l ₃	(l ₄)	d ₄	SW				
NJF3	4.826	7.92	6.35	15.88	10-32	26.97	11.1	34.91	10.31	7.92	11.11	10	5.4	0.018
	0.1900	0.312	0.250	0.625		1.062	0.437	1.375	0.406	0.312	0.437			
NJF4	6.35	9.53	7.14	19.05	1/4-28	33.32	14.27	42.85	11.89	9.52	12.7	13	11.11	0.027
	0.2500	0.375	0.281	0.750		1.312	0.562	1.687	0.468	0.375	0.500			
NJF5	7.938	11.10	8.74	22.23	5/16-24	34.92	15.88	46.03	12.7	11.1	15.88	10	12.2	0.040
	0.3125	0.437	0.344	0.875		1.375	0.625	1.812	0.500	0.437	0.625			
NJF6	9.525	12.7	10.31	25.4	3/8-24	41.28	19.05	53.98	17.45	14.27	18.26	9	17.5	0.068
	0.3750	0.500	0.406	1.000		1.625	0.75	2.125	0.687	0.562	0.719			
NJF7	11.11	14.27	11.1	28.58	7/16-20	46.02	22.22	60.31	19.05	15.88	20.62	11	19.1	0.090
	0.4375	0.562	0.437	1.125		1.812	0.875	2.375	0.750	0.625	0.812			
NJF8	12.7	15.88	12.7	33.32	1/2-20	53.98	25.4	70.64	22.22	19.05	23.8	9	28.7	0.149
	0.5000	0.625	0.500	1.312		2.125	1.000	2.781	0.875	0.750	0.937			
NJF10	15.875	19.05	14.27	38.1	5/8-18	63.5	31.75	82.55	25.4	22.23	28.58	11	32.9	0.217
	0.6250	0.750	0.562	1.500		2.5	1.250	3.250	1.000	0.875	1.125			
NJF12	19.05	22.23	17.45	44.45	3/4-16	73.02	38.1	95.25	28.58	25.4	33.33	10	48.6	0.326
	0.7500	0.875	0.687	1.750		2.875	1.500	3.750	1.125	1.000	1.312			

Notes: For studs add " Y " to suffix , Example: NJF6Y

Can supply rod ends with different pitch or accuracy of thread.

For left-hand thread, suffix"L" is added to bearing numbers. eg.: NJFL12 3/4-16L

NJM..

- Ball: Gcr15 Steel, heat treated, HRC56min;
precision ground, polished hard
chromium plated
- Body: Carbon steel, zinc plated, chromate treated
- Race: PTFE lubricated, fiber reinforced
engineering plastic
- Sliding contact surfaces: Steel/engineering plastic

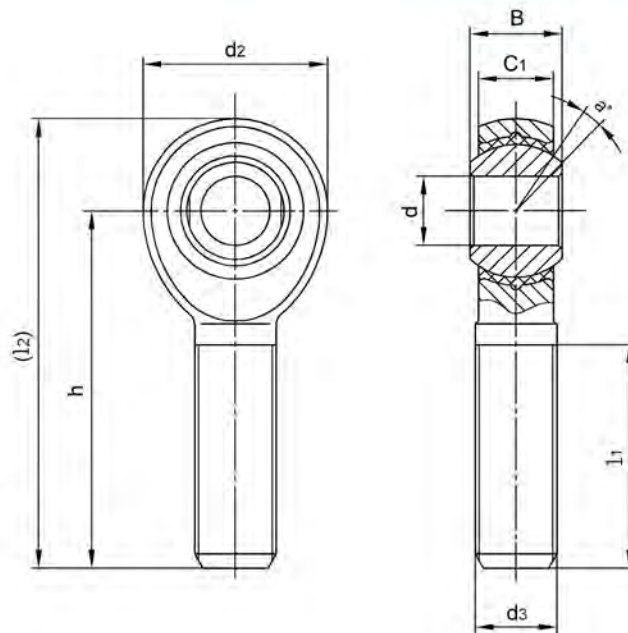

Bearing No.	Dimensions(mm/inches)								Ball dia	a° mis. angle	Load ratings (KN)	weight ≈ kg
	d ^{+0.036/-0.012}	B	C ₁	d ₂	d ₃ UNF-2A	h	l ₁	(l ₂)				
NJM3	4.826	7.92	6.35	15.88	10-32	31.75	19.05	39.69	11.11	10	4.4	0.013
	0.1900	0.312	0.250	0.625		1.250	0.750	1.562	0.437			
NJM4	6.35	9.53	7.14	19.05	1/4-28	39.67	25.4	49.2	12.7	13	8.2	0.018
	0.2500	0.375	0.281	0.750		1.562	1.000	1.937	0.500			
NJM5	7.938	11.10	8.74	22.23	5/16-24	47.63	31.75	58.75	15.88	10	12.3	0.031
	0.3125	0.437	0.344	0.875		1.875	1.250	2.312	0.625			
NJM6	9.525	12.7	10.31	25.4	3/8-24	49.22	31.75	61.92	18.26	9	17.8	0.049
	0.3750	0.500	0.406	1.000		1.938	1.250	2.687	0.719			
NJM7	11.112	14.27	11.1	28.58	7/16-20	53.98	34.93	68.27	20.62	11	18.8	0.072
	0.4375	0.562	0.437	1.125		2.125	1.375	2.678	0.812			
NJM8	12.7	15.88	12.7	33.32	1/2-20	61.92	38.1	78.58	23.8	9	28.7	0.113
	0.5000	0.625	0.500	1.312		2.438	1.500	3.093	0.937			
NJM10	15.875	19.05	14.27	38.1	5/8-18	66.68	41.28	85.73	28.58	11	32.9	0.172
	0.6250	0.750	0.562	1.500		2.625	1.625	3.375	1.125			
NJM12	19.05	22.23	17.45	44.45	3/4-16	73.02	44.45	95.25	33.33	10	48.6	0.272
	0.7500	0.875	0.687	1.750		2.875	1.750	3.750	1.312			

Notes: For studs add " Y " to suffix , Example: NJM6Y
 Can supply rod ends with different pitch or accuracy of thread.
 For left-hand thread, suffix"L" is added to bearing numbers. eg.: NJML12 3/4-16L

NAF..

Ball: Gcr15 Steel, heat treated, HRC56min;

Precision ground, polished, hard
chromium plated

Body: Aluminum 6061-T6, hard anodized red

Race: Nylon polymer PTFE additive

Sliding contact surfaces: Steel/Nylon

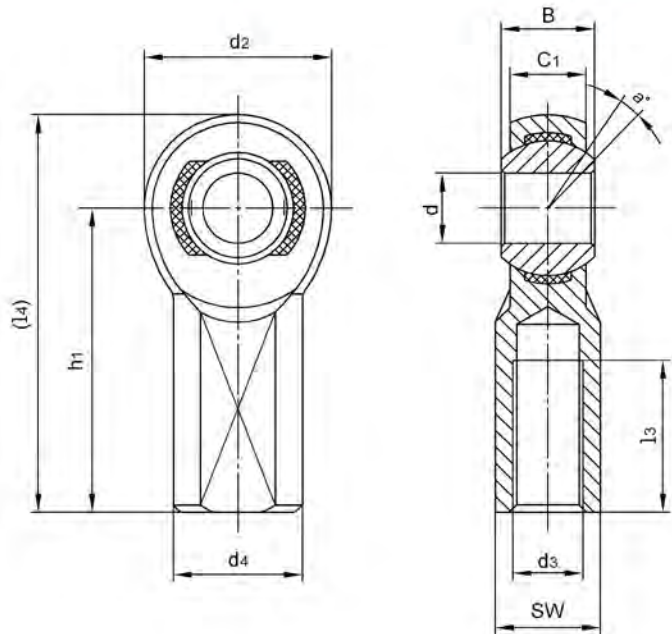

Bearing No.	Dimensions(mm/inches)										Ball dia	a° mis. angle	Load ratings (KN)	weight ≈ g
	d	B	C1	d2	d3 UNF-2B	h1	l3	(l4)	d4	SW				
NAF3	4.826	7.92	6.35	15.88	10-32	26.97	11.1	34.91	10.31	7.92	11.11	10	6.8	18
	0.1900	0.312	0.250	0.625		1.062	0.437	1.375	0.406	0.312	0.437			
NAF4	6.35	9.53	7.14	19.05	1/4-28	33.32	14.27	42.85	11.89	9.52	12.7	13	11.2	27
	0.2500	0.375	0.281	0.750		1.312	0.562	1.687	0.468	0.375	0.500			
NAF5	7.938	11.10	8.74	22.23	5/16-24	34.92	15.88	46.03	12.7	11.1	15.88	10	13.9	40.8
	0.3125	0.437	0.344	0.875		1.375	0.625	1.812	0.500	0.437	0.625			
NAF6	9.525	12.7	10.31	25.4	3/8-24	41.28	19.05	53.98	17.45	14.27	18.26	9	17.4	63
	0.3750	0.500	0.406	1.000		1.625	0.75	2.125	0.687	0.562	0.719			
NAF7	11.11	14.27	11.1	28.58	7/16-20	46.02	22.22	60.31	19.05	15.88	20.62	11	18.7	86.2
	0.4375	0.562	0.437	1.125		1.812	0.875	2.375	0.750	0.625	0.812			
NAF8	12.7	15.88	12.7	33.32	1/2-20	53.98	25.4	70.64	22.22	19.05	23.8	9	29.6	140.6
	0.500	0.625	0.500	1.312		2.125	1.000	2.781	0.875	0.750	0.937			
NAF10	15.875	19.05	14.27	38.1	5/8-18	63.5	31.75	82.55	25.4	22.23	28.58	11	32.7	204
	0.6250	0.750	0.562	1.500		2.5	1.250	3.250	1.000	0.875	1.125			
NAF12	19.05	22.23	17.45	44.45	3/4-16	73.02	38.1	95.25	28.58	25.4	33.33	10	51.2	313
	0.7500	0.875	0.687	1.750		2.875	1.500	3.750	1.125	1.000	1.312			

Can supply rod ends with different pitch or accuracy of thread.

Aluminum 7075-T6 is available upon request.

For left-hand thread, suffix"L" is added to bearing numbers. eg.: NAFL6 3/8-24L

NAM..

Ball: Gcr15 Steel, heat treated, HRC56min;

Precision ground, polished hard
chromium plated

Body: Aluminum 6061-T6, hard anodized red

Race: Nylon polymer PTFE additive

Sliding contact surfaces: Steel/Nylon

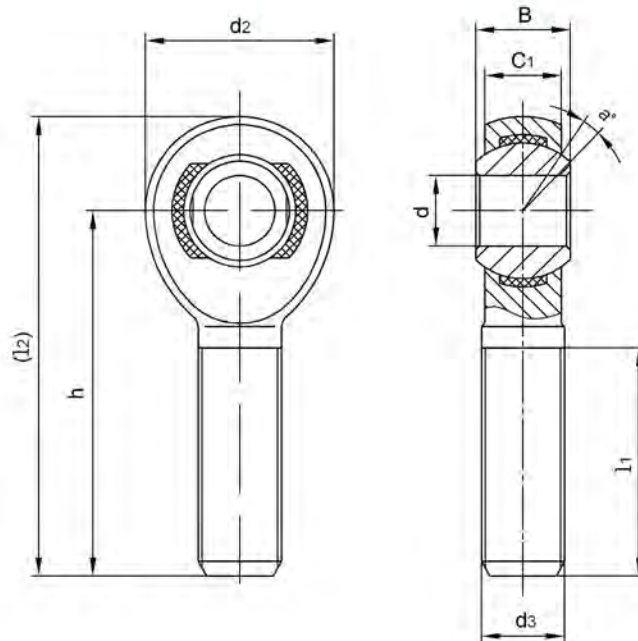

Bearing No.	Dimensions(mm/inches)								Ball dia	a° mis. angle	Load ratings (KN)	weight ≈ g
	d ^{+0.036 -0.012}	B	C1	d2	d3 UNF-2A	h	l1	(l2)				
NAM3	4.826	7.92	6.35	15.88	10-32	31.75	19.05	39.69	11.11	10	5.1	13.6
	0.1900	0.312	0.250	0.625		1.250	0.750	1.562	0.437			
NAM4	6.35	9.53	7.14	19.05	1/4-28	39.67	25.4	49.2	12.7	13	9.5	18
	0.2500	0.375	0.281	0.750		1.562	1.000	1.937	0.500			
NAM5	7.938	11.10	8.74	22.23	5/16-24	47.63	31.75	58.75	15.88	10	12.3	31.7
	0.3125	0.437	0.344	0.875		1.875	1.250	2.312	0.625			
NAM6	9.525	12.7	10.31	25.4	3/8-24	49.22	31.75	61.93	18.26	9	17.4	49.8
	0.3750	0.500	0.406	1.000		1.938	1.250	2.438	0.719			
NAM7	11.112	14.27	11.1	28.58	7/16-20	53.98	34.93	68.27	20.62	11	18.7	68
	0.4375	0.562	0.437	1.125		2.125	1.375	2.678	0.812			
NAM8	12.7	15.88	12.7	33.32	1/2-20	61.93	38.1	78.58	23.8	9	29.6	108.8
	0.5000	0.625	0.500	1.312		2.438	1.500	3.093	0.937			
NAM10	15.875	19.05	14.27	38.1	5/8-18	66.68	41.28	85.73	28.58	11	32.7	163.3
	0.6250	0.750	0.562	1.500		2.625	1.625	3.375	1.125			
NAM12	19.05	22.23	17.45	44.45	3/4-16	73.02	44.45	95.25	33.33	10	51.2	258.5
	0.7500	0.875	0.687	1.750		2.875	1.750	3.750	1.312			

Can supply rod ends with different pitch or accuracy of thread.

Aluminum 7075-T6 is available upon request.

For left-hand thread, suffix "L" is added to bearing numbers. eg.: NAML6 3/4-16L

ALJF..

Ball: Gcr15 Steel, heat treated, HRC56min;
 precision ground, polished, hard
 chromium plated

Body: Aluminum 6061-T6, hard anodized red

Race: Steel alloy, heat treated, zinc plated, chromate treated

Sliding contact surfaces: Steel/Steel

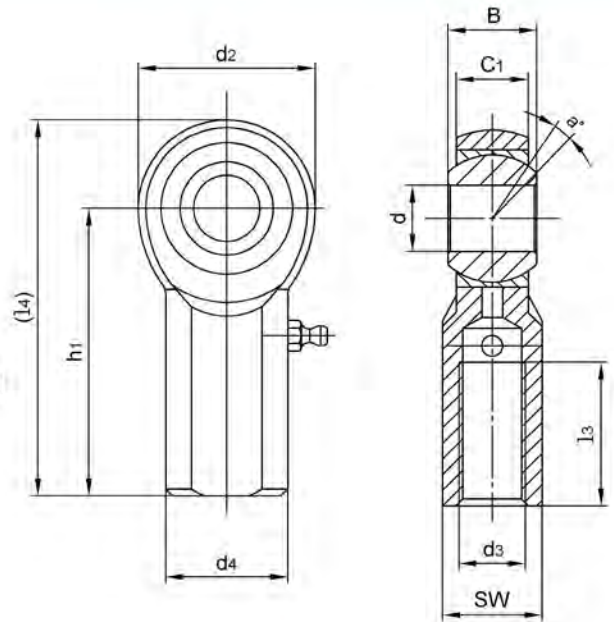

Bearing No.	Dimensions(mm/inches)										Ball dia	a° mis. angle	Load ratings (KN)	weight ≈ kg
	d ^{+0.038} _{-0.012}	B	C ₁	d ₂	d ₃ _{UNF-2B}	h ₁	l ₃	(l ₄)	d ₄	SW				
ALJF3	4.826	7.92	6.35	15.88	10-32	26.97	11.1	34.91	10.31	7.92	11.11	10	4.4	0.018
	0.1900	0.312	0.250	0.625		1.062	0.437	1.375	0.406	0.312	7/16			
ALJF4	6.35	9.53	7.14	19.05	1/4-28	33.32	14.27	42.85	11.89	9.52	12.7	13	7.4	0.027
	0.2500	0.375	0.281	0.750		1.312	0.562	1.687	0.468	0.375	1/2			
ALJF5	7.938	11.10	8.74	22.23	5/16-24	34.92	15.88	46.03	12.7	11.1	15.88	10	9.1	0.040
	0.3125	0.437	0.344	0.875		1.375	0.625	1.812	0.500	0.437	5/8			
ALJF6	9.525	12.7	10.31	25.4	3/8-24	41.28	19.05	53.98	17.45	14.27	18.26	9	10.9	0.068
	0.3750	0.500	0.406	1.000		1.625	0.75	2.125	0.687	0.562	23/32			
ALJF7	11.11	14.27	11.1	28.58	7/16-20	46.02	22.22	60.31	19.05	15.88	20.62	11	15.1	0.090
	0.4375	0.562	0.437	1.125		1.812	0.875	2.375	0.750	0.625	13/16			
ALJF8	12.7	15.88	12.7	33.32	1/2-20	53.98	25.4	70.64	22.22	19.05	23.8	9	23.8	0.149
	0.500	0.625	0.500	1.312		2.125	1.000	2.781	0.875	0.750	15/16			

Notes: For grease fittings add "Z" to suffix. Example: ALJF6Z
 For studs add "Y" to suffix. Example: ALJF5Y
 For teflon liner add "T" to suffix. Example: ALJF8T

Can supply rod ends with different pitch or accuracy of thread.

For left-hand thread, suffix "L" is added to bearing numbers. eg.: ALJFL6 3/8-24L

ALJM..

Ball: Gcr15 Steel, heat treated, HRC56min;
 precision ground, polished, hard
 chromium plated

Body: Aluminum 6061-T6, hard anodized red

Race: Steel alloy, heat treated, zinc plated,
 chromate treated

Sliding contact surfaces: Steel/Steel

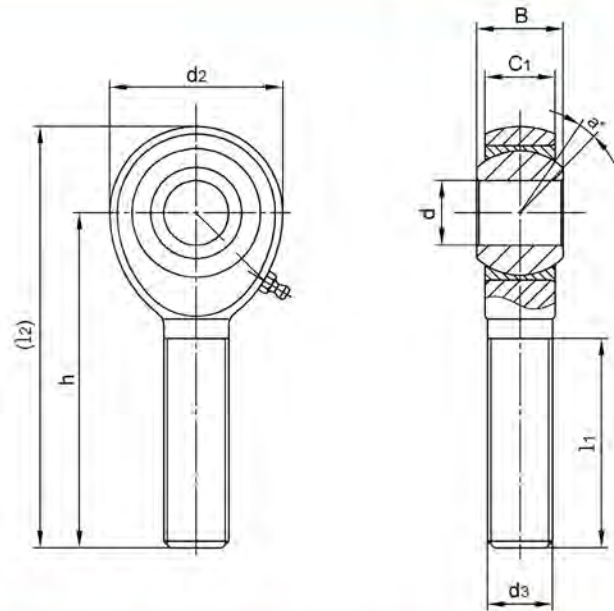

Bearing No.	Dimensions(mm/inches)								Ball dia	a° mis. angle	Load ratings (KN)	weight ≈ kg
	d ^{+0.038 -0.012}	B	C1	d2	d3 UNF-2A	h	l1	(L2)				
ALJM3	4.826	7.92	6.35	15.88	10-32	31.75	19.05	39.69	11.11	10	3.6	0.009
	0.1900	0.312	0.250	0.625		1.250	0.750	1.562	0.437			
ALJM4	6.35	9.53	7.14	19.05	1/4-28	39.67	25.4	49.2	12.7	13	6.7	0.015
	0.2500	0.375	0.281	0.750		1.562	1.000	1.937	0.500			
ALJM5	7.938	11.10	8.74	22.23	5/16-24	47.63	31.75	58.75	15.88	10	9.1	0.022
	0.3125	0.437	0.344	0.875		1.875	1.250	2.312	0.625			
ALJM6	9.525	12.7	10.31	25.4	3/8-24	49.22	31.75	61.92	18.26	9	10.9	0.035
	0.3750	0.500	0.406	1.000		1.938	1.250	2.687	0.719			
ALJM7	11.112	14.27	11.1	28.58	7/16-20	53.98	34.93	68.27	20.62	11	15.1	0.041
	0.4375	0.562	0.437	1.125		2.125	1.375	2.678	0.812			
ALJM8	12.7	15.88	12.7	33.32	1/2-20	61.92	38.1	78.58	23.8	9	23.8	0.063
	0.5000	0.625	0.500	1.312		2.438	1.500	3.093	0.937			
ALJM8H	12.7	15.88	12.7	33.32	1/2-20	61.92	38.1	78.58	23.8	9	28.7	
	0.5000	0.625	0.500	1.312		2.438	1.500	3.093	0.937			
ALJM10	15.875	19.05	14.27	38.1	5/8-18	66.68	41.28	85.73	28.58	11	25.5	0.108
	0.6250	0.750	0.562	1.500		2.625	1.625	3.375	1.125			
ALJM10H	15.875	19.05	14.27	44.45	5/8-18	66.68	41.28	85.73	28.58	11	33.6	0.121
	0.6250	0.750	0.562	1.750		2.625	1.625	3.375	1.125			
ALJM12	19.05	22.23	17.45	44.45	3/4-16	73.02	44.45	95.25	33.33	10	69.5	0.136
	0.7500	0.875	0.687	1.750		2.875	1.750	3.750	1.312			
ALJM12H	19.05	22.23	17.45	50.8	3/4-16	73.02	44.45	95.25	33.33	10	91.6	0.136
	0.7500	0.875	0.687	2.000		2.875	1.750	3.750	1.312			

Notes: For grease fittings add "Z" to suffix. Example: ALJM6Z
 For studs add "Y" to suffix. Example: ALJM5Y
 For teflon liner add "T" to suffix. Example: ALJM8T

Can supply rod ends with different pitch or accuracy of thread.

For left-hand thread, suffix "L" is added to bearing numbers. eg.: ALJML6 3/8-24L

ALRSM..

Ball: Gcr15 Steel, heat treated, HRC56min;
precision ground, polished, hard
chromium plated

Body: Aluminum 6061-T6, hard anodized red

Race: Steel alloy, heat treated, zinc plated,
chromate treated

Sliding contact surfaces: Steel/Steel

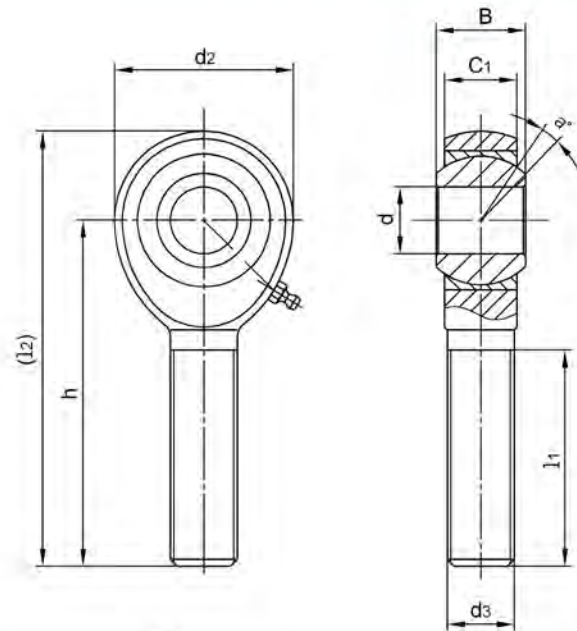

Bearing No.	Dimensions(mm/inches)								Ball dia	a° mis. angle	Load ratings (KN)	weight ≈ kg
	d $\begin{smallmatrix} +0.030 \\ -0.012 \end{smallmatrix}$	B	C1	d2	d3 UNF-2A	h	l1	(l2)				
ALRSM6	9.525	12.7	10.31	28.58	7/16-20	53.98	34.93	68.27	18.26	14	34.3	0.033
	0.3750	0.500	0.406	1.125		2.125	1.375	2.678	0.719			
ALRSM7	11.112	14.27	11.1	33.32	1/2-20	61.92	38.1	78.58	20.62	12	48.9	0.054
	0.4375	0.562	0.437	1.312		2.438	1.500	3.093	0.812			
ALRSM8	12.7	15.88	12.7	38.1	5/8-18	66.68	41.28	85.73	23.8	12	66.1	0.090
	0.5000	0.625	0.500	1.500		2.625	1.625	3.375	0.937			
ALRSM10	15.875	19.05	14.27	44.45	3/4-16	73.02	44.45	95.25	28.58	16	85.5	0.143
	0.6250	0.750	0.562	1.750		2.875	1.750	3.750	1.125			
ALRSM10-8	12.7	19.05	14.27	44.45	3/4-16	73.02	44.45	95.25	28.58	16	85.5	0.143
	0.500	0.750	0.562	1.750		2.875	1.750	3.750	1.125			

Notes: For grease fittings add "Z" to suffix. Example: ALRSM6Z

For teflon liner add "T" to suffix. Example: ALRSM8T

Can supply rod ends with different pitch or accuracy of thread.

For left-hand thread, suffix "L" is added to bearing numbers. eg.: ALRSM10-8L 3/4-16



SQ..RS

Ball: Gcr15 Steel

Body: Zinc alloy

Stud: Carbon steel, black oxidized

Sliding contact surfaces: Steel/Zinc base alloy

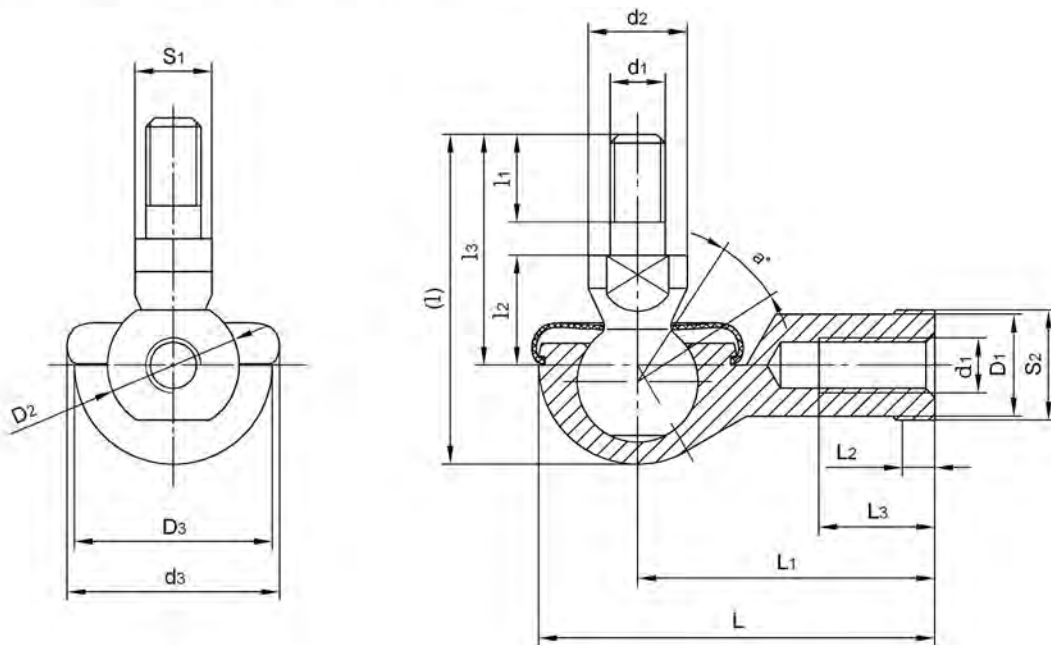

Bearing No.	Dimensions(mm)																a° mis. angle	Load ratings KN	weight ≈ kg
	d2	d3	d3-6g	l	l1	l2	l3	S1	L	L1	L2	L3	D1	D2	D3	S2			
SQ5-RS	9	19	M5	29	8	10	21	7	35	27	4	14	9	11	16	9	25	2.2	0.026
SQ6-RS	10	20	M6	35.5	11	11	26	8	40	30	5	14	10	13	19	11	25	3.5	0.039
SQ8-RS	12	24	M8	42.5	12	14	31	10	48	36	5	17	12.5	16	23	14	25	6.6	0.068
SQ10-RS	14	30	M10x1.25	50.5	15	17	37	11	57	43	6.5	21	15	19	27	17	25	10	0.112
SQ12-RS	17	32	M12x1.25	57.5	17	19	42	15	66	50	6.5	25	17.5	22	31	19	25	16	0.164
SQ14-RS	19	38	M14x1.5	73.5	22	21.5	56	17	75	57	8	26	20	25	35	22	25	19	0.254
SQ16-RS	22	44	M16x1.5	79.5	23	23.5	60	19	84	64	8	32	22	27	39	22	20	26	0.336
SQ18-RS	23	45	M18x1.5	90	25	26.5	68	20	93	71	10	34	25	31	44	27	20	33	0.464
SQ20-RS	27	50	M20x1.5	90	25	27	68	24	99	77	10	35	27.5	34	44	30	20	45	0.538
SQ22-RS	27	52	M22x1.5	95	26	28	70	24	109	84	12	41	30	37	50	32	16	48	0.713

The shank of ball joint housing may be left-hand thread, for left-hand thread, suffix "L" is added to bearing number and thread sign, e.g. SQL5-RS M5L-6H

SQZ..RS

Ball: Gcr15 Steel

Body: Zinc alloy

Stud: Carbon steel, black oxidized

Sliding contact surfaces: Steel/Zinc base alloy

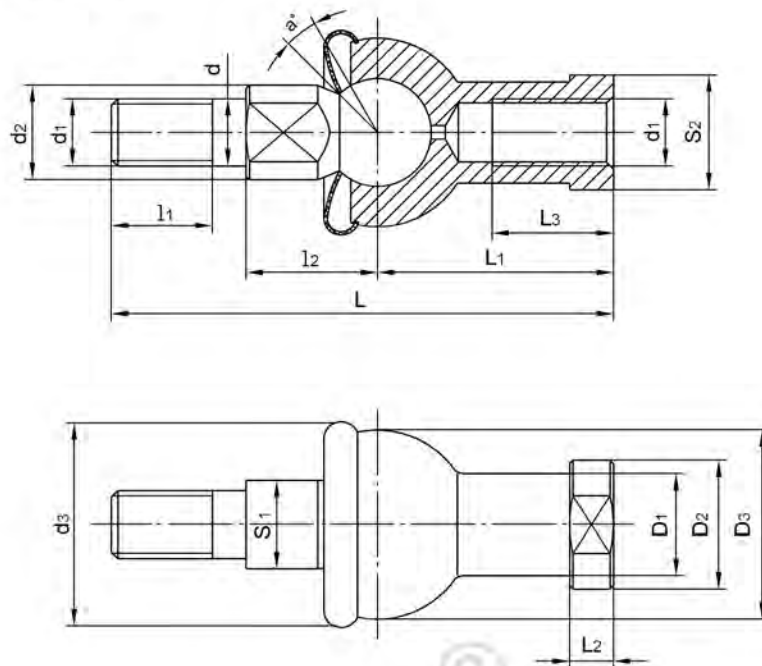

Bearing No.	Dimensions(mm)															Static Load KN ratings	a° mis. angle	weight ≈ kg
	d	d3-6g	d2	d3	l1	l2	S1	L	L1	L2	L3	D1	D2	D3	S2			
SQZ5-RS	5	M5	9	19	8	11	7	46	24	4	12	9	11	17	9	2.8	15	0.025
SQZ6-RS	6	M6	10	20	11	12.2	8	55.2	28	5	15	10	13	20	11	3.7	15	0.041
SQZ8-RS	8	M8	12	24	12	16	10	65	32	5	16	12.5	16	24	14	5.8	15	0.075
SQZ10-RS	10	M10x1.25	14	30	15	19.5	11	74.5	35	6.5	18	15	19	28	17	8.4	15	0.12
SQZ12-RS	12	M12x1.25	17	32	17	21	15	84	40	6.5	20	17.5	22	32	19	11	15	0.18
SQZ14-RS	14	M14x1.5	19	38	22	23.5	17	103	45	8	25	20	25	36	22	15	11	0.27
SQZ16-RS	16	M16x1.5	22	44	23	25.5	19	112	50	8	27	22	27	40	22	15	11	0.36
SQZ18-RS	18	M18x1.5	23	45	25	31	20	130.5	58	10	32	25	31	45	27	19	11	0.54
SQZ20-RS	20	M20x1.5	27	50	25	29	24	133	63	10	38	27.5	34	45	30	19	7.5	0.57
SQZ22-RS	22	M22x1.5	27	52	26	33	24	145	70	12	43	30	37	50	32	23	7.5	0.76

The shank of ball joint housing may be left-hand thread, for left-hand thread, suffix "L" is added to bearing number and thread sign, e.g./SQZL5-RS M5L-6H

SQD..

Ball: Gcr15 Steel

Body: Zinc alloy

Stud: Carbon steel, black oxidized

Sliding contact surfaces: Steel/Zinc base alloy

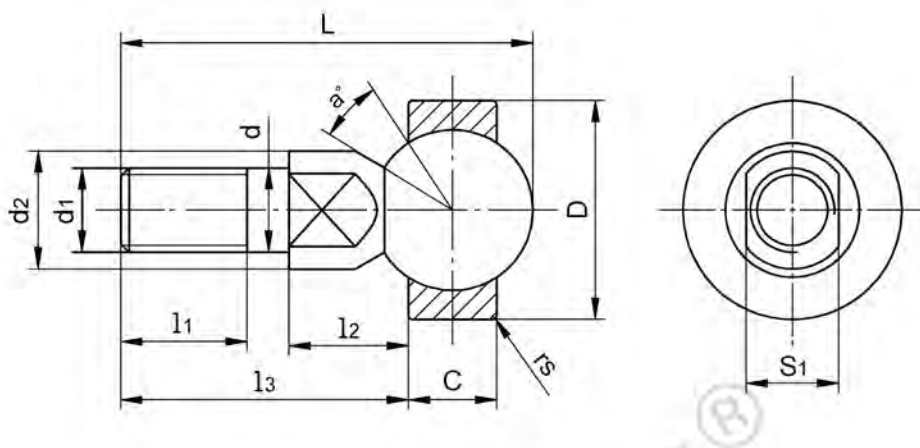

Bearing No.	Dimensions(mm)										Static Load ratings KN	a° mis. angle	weight ≈ kg
	d	d3-6g	d2	l2	l3	L	S1	C	D	rs			
SQD5	5	M5	9	8	19	27.5	7	6	16	0.3	2.0	25	0.014
SQD6	6	M6	10	11	23.8	33.5	8	6.75	18	0.3	3.2	25	0.021
SQD8	8	M8	12	12	28.6	41	10	9	22	0.3	5.7	25	0.042
SQD10	10	M10x1.25	14	15	34.2	49	11	10.5	26	0.3	9.2	25	0.067
SQD12	12	M12x1.25	17	17	38.1	55.1	15	12	30	0.5	14	25	0.108
SQD14	14	M14x1.5	19	22	51.3	70.7	17	13.5	34	0.5	19	20	0.167
SQD16	16	M16x1.5	22	23	54.5	76.3	19	15	38	0.5	26	20	0.238

AS BALL JOINT Metric sizes

Material:

Body and ball stud: Low carbon steel.

Liner: Nylon polymer.

Protective Finish:

Body and ball stud zinc plated and yellow passivated.

Features

- The Nylon polymer liner provides long life and an ultra smooth bearing surface.
- Optional polychloroprene gaiter available to help resist dirt ingress.
- If a fitted gaiter is required. please add G to the part number e.g. ASG 8.
- Spanner flats on ball studs and bodies facilitate assembly.
- Polished ball for smoother operation.
- Subject to quantity, special threaded bodies and ball studs are available.

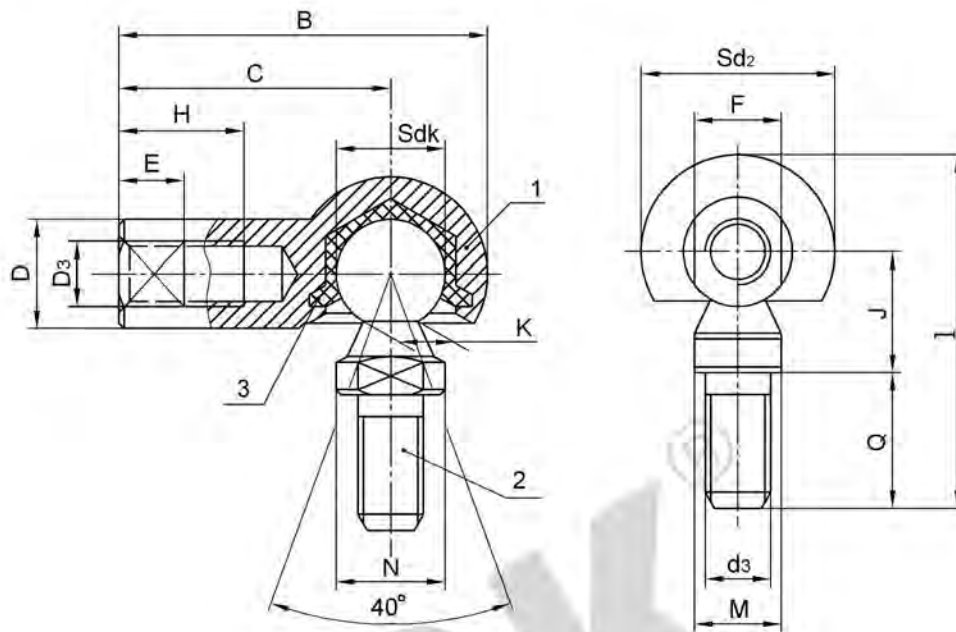

Bearing No	Dimensions(mm)																weight Per 100 in kg
	Sd2	H	D3-6H	sdk	d3-62	K	F ⁰ _{-0.2}	M ⁰ _{-0.2}	B	C	E	D	L	Q	J	N	
AS6	17.8	11.5	M6	10	M6	5	8	8	33	25	6	10	32.5	12.5	11	10	2.8
AS8	20.8	14	M8	13	M8	6.5	11	11	40	30	8	13	40	16.5	13	13	4.9
AS10	23.8	15.5	M10	16	M10	8	14	12	46.3	35	10	16	48	20	16	16	8.3
AS12	23.8	25.5	M12	16	M12	8	14	13	56.3	45	12	16	48	20	16	16	9.0

BS BALL JOINT Metric sizes

Body: Grey Nylon polymer with Molybdenum Disulphide additive.

Ball stud: Low carbon steel.

Protective Finish:

Ball stud zinc plated and yellow passivated.

Features

- Body moulded complete in one piece.
- Light weight and low cost.
- High strength to weight ratio.
- Molybdenum Disulphide additive ensures permanent lubrication.
- An optional polychloroprene gaiter available to help resist dirt ingress.
If a fitted gaiter is required, please add G to the part number e.g. BSG 8.
- BM Ball Joint is available without a ball stud for assembly on to a pre-positioned stud.
- Spanner flats on bodies and ball studs facilitate assembly.
- Polished ball for smoother operation.
- Subject to quantity, special Threaded Ball Studs are available.

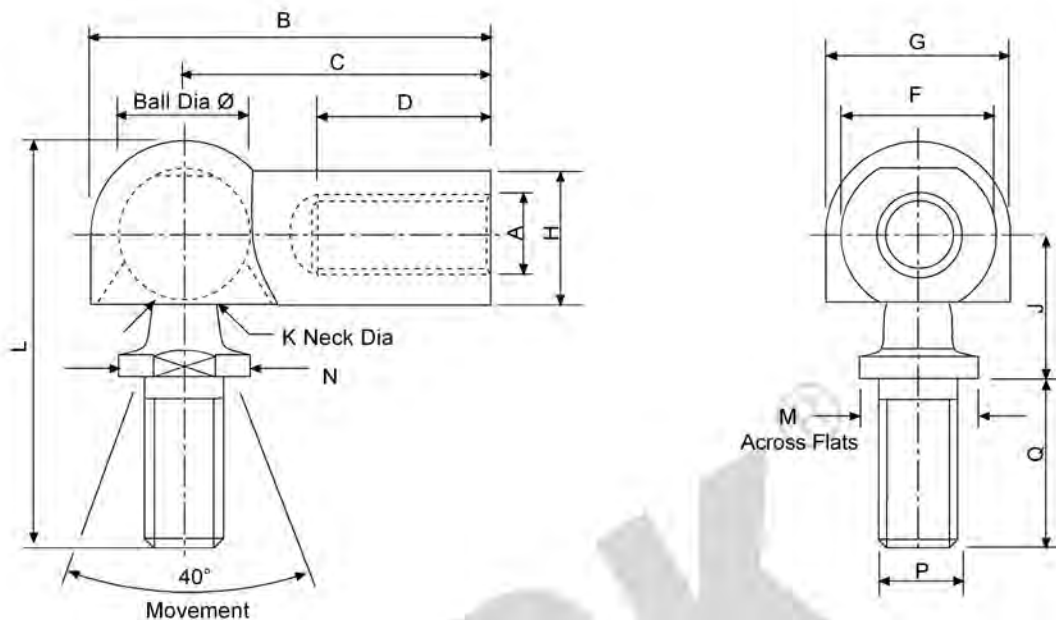

Part No	Thread I.S.O. A	Dimensions(mm)											Thread I.S.O. P	Q	Ball Dia. Ø	Weight per 100 in Kgs
		B	C	D	F	G	H	J	K	L	M	N				
BS 5	M5x0.8	26.0	20	12	10	12.0	8	9	4.0	25.2	7	8	M5x0.8	10.2	8	0.7
BS 6	M6x1.0	31.2	24	14	12	14.5	10	11	5.0	30.8	8	10	M6x1.0	12.5	10	1.2
BS 8	M8x1.25	39.0	30	17	15	18.0	13	13	6.5	38.5	11	13	M8x1.25	16.5	13	2.9

CS..

CS Ball joint metric size

Material:

Body: low carbon steel.

Ball stud: carbon steel, ball is induction hardened

Inner retaining ring and safety clip: Hard drawn spring steel

Protective Finish:

Ball joint components zinc plated and clear passivated, ball stud,

inner retaining ring and safety clip are de-embrittled.

Features

Ball stud is retained by a captive internal wire ring.

Additional stud retention security is provided by the external wire safety clip.

For improved wear resistance, the ball is induction hardened,

Optional polychloroprene gaiter available to help resist dirt ingress.

If a fitted gaiter is required, please add G to the part number e.g. CSG 8/1.

Hexagon form on body.

Spanner flats are not available on CS 12/1 and 16/1.

Burnished ball for smoother operation.

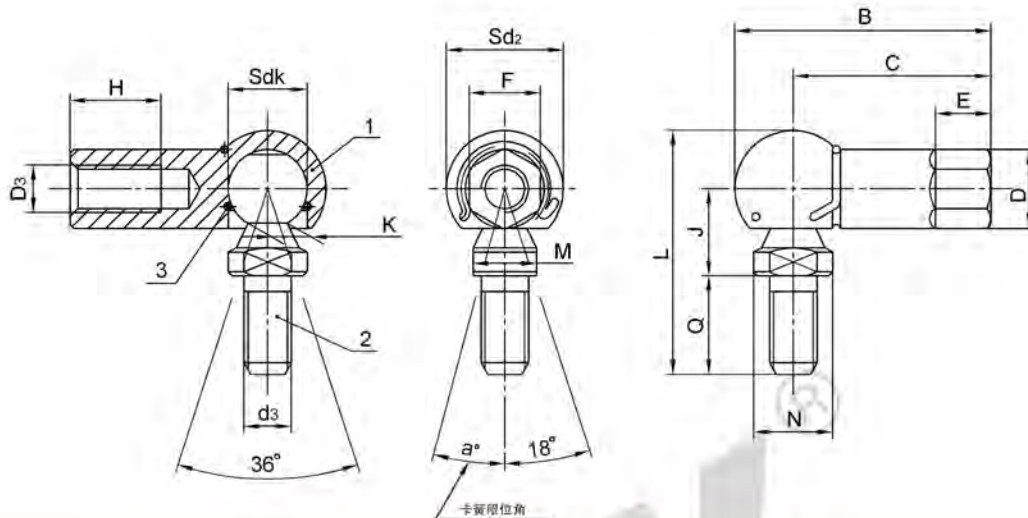

Bearing No.	Dimensions(mm)																	weight Per 100 in kg
	Sd ₂	H	D ₃	sdk	d ₃	K	F	M	a	B	C	E	D	L	Q	J	N	
CS5/1	12.8	10.2	M5	8	M5	4	7	7	10	28.4	22	5	8	25.4	10.2	9	8	1.3
CS6/1	14.8	11.5	M6	10	M6	5	9	8	15	32.4	25	7	10	30.4	12.5	11	10	2.2
CS8/1	19.3	14	M8	13	M8	6.5	11	11	15	39.6	30	9	13	38.6	16.5	13	13	4.5
CS10/1	24	15.5	M10	16	M10	8	13	13	15	47	35	9	16	47	20	16	16	8.6
CS12/1	24	15.5	M12	16	M12	8	13	13	15	47	35	9	16	47	20	16	16	8.6
CS14/1	30	21.5	M14	19	M14	10	19	16	15	60	45	12	22	63	28	20	19	19.2
CS16/1	30	21.5	M16	19	M16	10	19	16	15	60	45	12	22	63	28	20	19	19.2

R..G

Ball Joint With Rubber Grommet,
SAE J490/Type G/Style 2

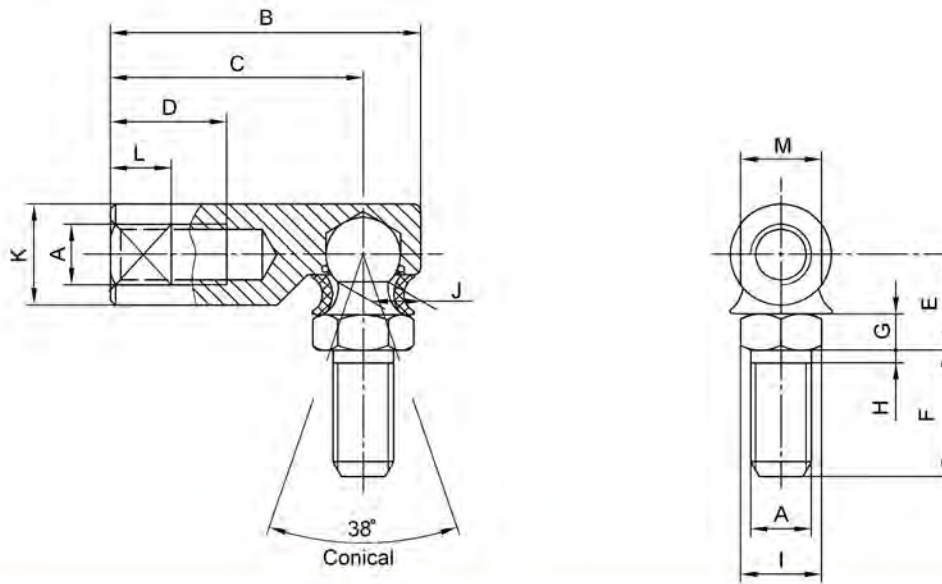

Bearing No.	Dimensions (inch/mm)													tensile shear strength (Pounds)	force to remove ball stud (Pounds)	
	A UNF	B	C	D	E	F	G	H	I	J	K	M	L			
R103G	10-32	1-1/16	7/8	7/16	7/16	7/16	7/16	1/8	1/16	5/16	0.172	3/8	8	6	295	690
		26.98	22.2	11.1	11.1	11.1	11.1	3.175	1.6	7.94	4.37	9.52				
R107G	1/4-28	1-7/32	31/32	1/2	15/32	9/16	1/8	3/32	3/8	0.193	7/16	8	6	882	1005	
		30.95	24.6	12.7	11.9	14.28	3.175	2.38	9.5	4.9	11.1					
R108G	5/16-24	1-13/32	1-1/8	9/16	17/32	11/16	5/32	3/32	7/16	0.232	1/2	10	7	1587	1282	
		35.71	28.58	14.28	13.5	17.46	4	2.38	11.1	5.8	12.7					
R109G	3/8-24	1/11/16	1-3/8	3/4	11/16	7/8	3/16	3/32	1/2	0.287	5/8	13	8	2437	1900	
		42.86	34.9	19.05	17.46	22.2	4.76	2.38	12.7	7.29	15.88					
I3-316	3/8-24	1/11/16	1-3/8	3/4	11/16	5/8	3/16	3/32	1/2	0.287	5/8	13	8	2437	1900	
		42.86	34.9	19.05	17.46	15.88	4.76	2.38	12.7	7.29	15.88					
R110G	7/16-20	2-3/8	1-15/16	1-1/8	7/8	1-1/8	1/4	1/8	5/8	0.412	3/4	16	10	3390	2700	
		60.32	49.2	28.58	22.22	28.58	6.35	3.17	15.88	10.46	19.05					
R111G	1/2-20	2-3/8	1-15/16	1-1/8	7/8	1-1/8	1/4	1/8	5/8	0.412	3/4	16	10	3390	2700	
		60.32	49.2	28.58	22.22	28.58	6.35	3.17	15.88	10.46	19.05					

Ball stud: Low carbon steel, heat treated
Zinc plated, yellow dichromate treated

Body: Low carbon steel, zinc plated, yellow dichromate treated

NOTE:

1. This series is also available in male to male and female to female configuration. Consult factory.

CEF DIN71752

Material: S235, Zinc plated

Stainless steel 304 is optional

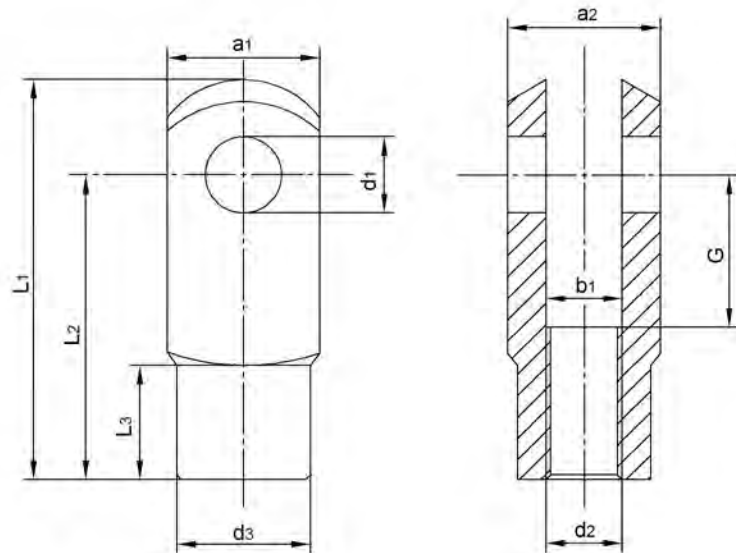

Bearing No.	d1 H9	G ± 0.5	a1 h11	a2 + 0.30 - 0.16	b + 0.70 - 0.15	d2	d3	L1 ± 0.2	L2 ± 0.4	L3 ± 0.2	weight ≈ Kg
CEF 4x8	4	8	8	8	4	M4	8	21	16	6	0.006
CEF 4x16	4	16	8	8	4	M4	8	29	24	6	0.008
CEF 5x10	5	10	10	10	5	M5	9	26	20	7.5	0.010
CEF 5x20	5	20	10	10	5	M5	9	36	30	7.5	0.014
CEF 6x12	6	12	12	12	6	M6	10	31	24	9	0.016
CEF 6x24	6	24	12	12	6	M6	10	43	36	9	0.023
CEF 8x16	8	16	16	16	8	M8	14	42	32	12	0.038
CEF 8x32	8	32	16	16	8	M8	14	58	48	12	0.055
CEF 10x20	10	20	20	20	10	M10	18	52	40	15	0.080
CEF 10x40	10	40	20	20	10	M10	18	72	60	15	0.120
CEF 12x24	12	24	24	24	12	M12	20	62	48	18	0.125
CEF 12x48	12	48	24	24	12	M12	20	86	72	18	0.180
CEF 14x28	14	28	28	28	14	M14	24	72	56	22.5	0.190
CEF 14x56	14	56	28	28	14	M14	24	101	85	22.5	0.265
CEF 16x32	16	32	32	32	16	M16	26	83	64	24	0.300
CEF 16x64	16	64	32	32	16	M16	26	115	96	24	0.430

All dimensions are in MM.

Different thread is available upon request.

CEM DIN71752

Material: S235,Zinc plated

Stainless steel 304 is optional

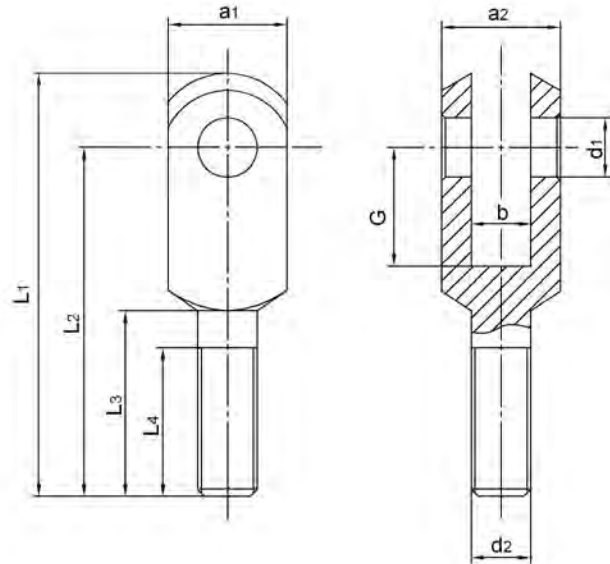

Bearing No.	d ₁ H9	G ±0,5	a ₁ h11	a ₂ +0.30 -0.16	b +0.70 -0.15	d ₂	L ₁ ±0.2	L ₂ ±0.4	L ₃ ±0.2	L ₄	weight ≈ Kg
CEM 6x12	6	12	12	12	6	M6x1	44	37	20	15	0.015
CEM 8x16	8	16	16	16	8	M8x1.25	57	47	25	20	0.036
CEM 10x20	10	20	20	20	10	M10x1.5	69	57	30	25	0.068
CEM 12x24	12	24	24	24	12	M12x1.75	82	68	35	30	0.122
CEM 14x28	14	28	27	27	14	M14x2	94	78	40	35	0.171
CEM 16x32	16	32	32	32	16	M16x2	108	89	45	40	0.288
CEM 20x40	20	40	40	40	20	M20x2.5	134	109	55	50	0.550

All dimensions are in MM.

Different thread is available upon request.

Y DIN71751

Material: S235,Zinc plated

Stainless steel 304 is optional

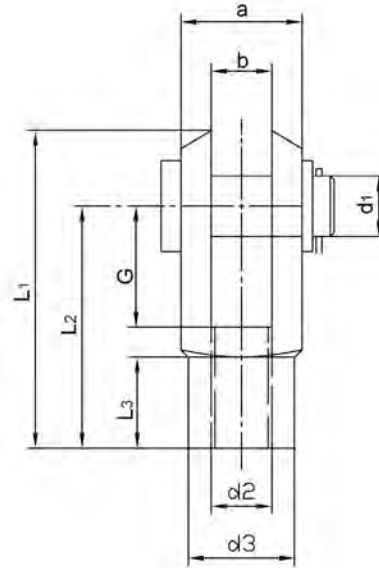

Bearing No.	d1	G	a	b	d2	d3	L1	L2	L3	weight ≈ Kg
Y 4x8	4	8	8	4	M4	8	21	16	6	0.006
Y 4x16	4	16	8	4	M4	8	29	24	6	0.008
Y 5x10	5	10	10	5	M5	9	26	20	7.5	0.010
Y 5x20	5	20	10	5	M5	9	36	30	7.5	0.014
Y 6x12	6	12	12	6	M6	10	31	24	9	0.016
Y 6x24	6	24	12	6	M6	10	43	36	9	0.023
Y 8x16	8	16	16	8	M8	14	42	32	12	0.038
Y 8x32	8	32	16	8	M8	14	58	48	12	0.055
Y 10x20	10	20	20	10	M10	18	52	40	15	0.080
Y10x40	10	40	20	10	M10	18	72	60	15	0.120
Y 12x24	12	24	24	12	M12	20	62	48	18	0.125
Y 12x48	12	48	24	12	M12	20	86	72	18	0.180
Y 14x28	14	28	28	14	M14	24	72	56	22.5	0.190
Y 14x56	14	56	28	14	M14	24	101	85	22.5	0.265
Y 16x32	16	32	32	16	M16	26	83	64	24	0.300
Y 16x64	16	64	32	16	M16	26	115	96	24	0.430

All dimensions are in MM.

Different thread is available upon request.

BSM DIN71803

Material: Carbon steel 1035,welded with ball

Surface treatment: Galvanized,passivated in Zinc/clear or Zinc/Yellow Optional 304 stainless steel

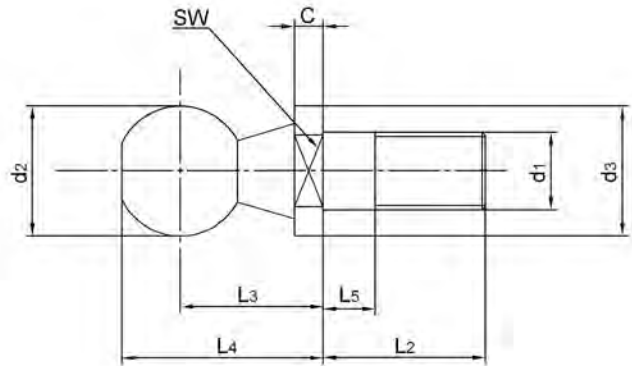

Bearing No.	d2	d1	d3	L2 ±0.3	L3 ±0.3	L4 ±0.3	L5 max	SW h14	C	weight ≈ Kg
BSM5	8	M5	8	10.2	9	12.5	4.0	7	2.0	0.004
BSM6	10	M6	10	12.5	11	15.5	4.0	8	2.2	0.008
BSM8	13	M8	13	16.5	13	18.5	5.3	11	2.4	0.016
BSM10	16	M10	16	20.0	16	23.0	7.3	13	2.7	0.024
BSM12	16	M12	16	20.0	16	23.0	7.3	13	2.7	0.030
BSM14	19	M14	19	28.0	20	28.5	10.8	16	3.0	0.056
BSM16	19	M16	19	28.0	20	28.5	10.8	16	3.0	0.063

All dimensions are in MM.

Different thread or dimensions are optional upon request.

BS DIN71805

Material: Carbon steel 1035

Surface treatment: Galvanized,
passivated in Zinc/clear or Zinc/Yellow

Optional 304 stainless steel

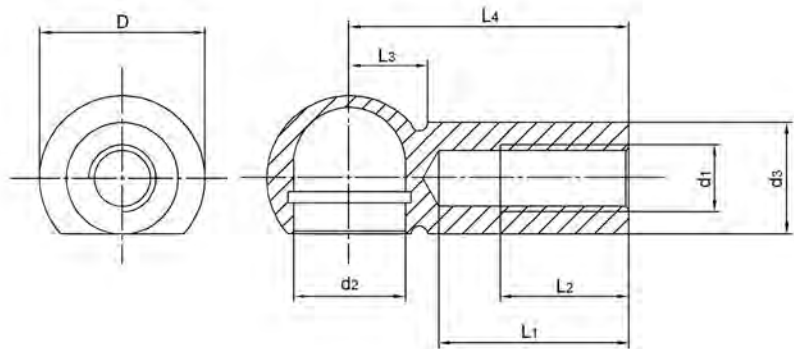

Bearing No.	d2	d1	d3 ± 0.3	D ± 0.5	L1 max	L2 min	L3 ± 0.5	a ± 0.3	weight ≈ Kg
BS5	8	M5	8	12.8	15	10.2	6.3	22	0.009
BS6	10	M6	10	14.8	17	11.5	7.0	25	0.014
BS8	13	M8	13	19.3	20	14.0	9.1	30	0.029
BS10	16	M10	16	24.0	22	15.5	11.4	35	0.057
BS12	16	M12	16	24.0	22	15.5	11.4	35	0.056
BS14	19	M14	22	30.0	28	21.5	12.5	45	0.125
BS16	19	M16	22	30.0	28	21.5	12.5	45	0.120

All dimensions are in MM.

Different thread or dimensions are optional upon request.

SK..E & SK..ES

Body: weldable steel, with dowel pin on shanks,

SK..E: Mounted GE..E type of radial spherical plain bearings.

SK..ES: Mounted with GE..ES type of radial spherical plain bearings.

Sliding contact surfaces: Steel/Steel

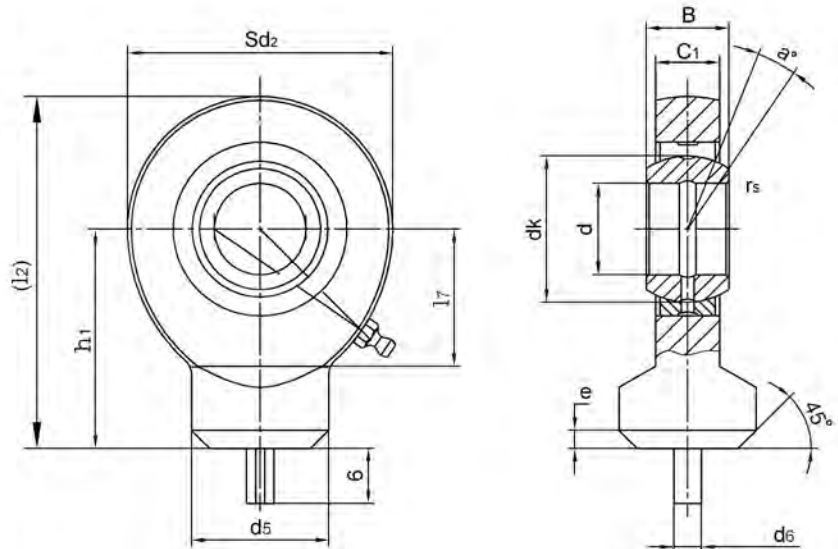

Bearing No.	Dimensions(mm)											a° mis. angle	Load ratings (KN)		Weight ≈ kg
	d	B	dk	C1	d2	d5	d6	h1	e	l7	(l2)		Dynamic	Static	
SK10E ¹⁾	10	9	16	7	29	15	3	24	2	15	38.5	12	8.1	15	0.041
SK12E ¹⁾	12	10	18	8	34	17.5	3	27	2	18	44	10	10	21	0.066
SK15ES ²⁾	15	12	22	10	40	21	4	31	2.5	20	51	8	16	32	0.12
SK17ES ²⁾	17	14	25	11	46	24	4	35	2.5	23	58	10	21	40	0.19
SK20ES	20	16	29	13	53	27.5	4	38	2.5	27	64.5	9	30	54	0.26
SK25ES	25	20	35.5	17	64	33.5	4	45	3	32	77	7	48	72	0.45
SK30ES	30	22	40.7	19	73	40	4	51	3	37	87.5	6	62	95	0.067
SK35ES	35	25	47	21	82	47	4	61	3	42	102	6	79	125	1.02
SK40ES	40	28	53	23	92	52	4	69	4	48	115	7	99	156	1.04
SK45ES	45	32	60	27	102	58	6	77	5	52	128	7	127	208	1.93
SK50ES	50	35	66	30	112	62	6	88	5	60	144	6	156	250	2.68
SK60ES	60	44	80	38	135	70	6	100	5	75	167.5	6	245	390	4.6
SK70ES	70	49	92	42	160	80	6	115	6	87	195	6	313	510	7.0
SK80ES	80	55	105	47	180	95	6	141	6	100	231	6	400	620	11.0

Can not be relubricated.

Can only be relubricated through the rod end housing.

SF..ES

Body: weldable steel, with dowel pin on shanks,

SF..ES: Mounted with GE..ES type of radial spherical plain bearings.

Sliding contact surfaces: Steel/Steel

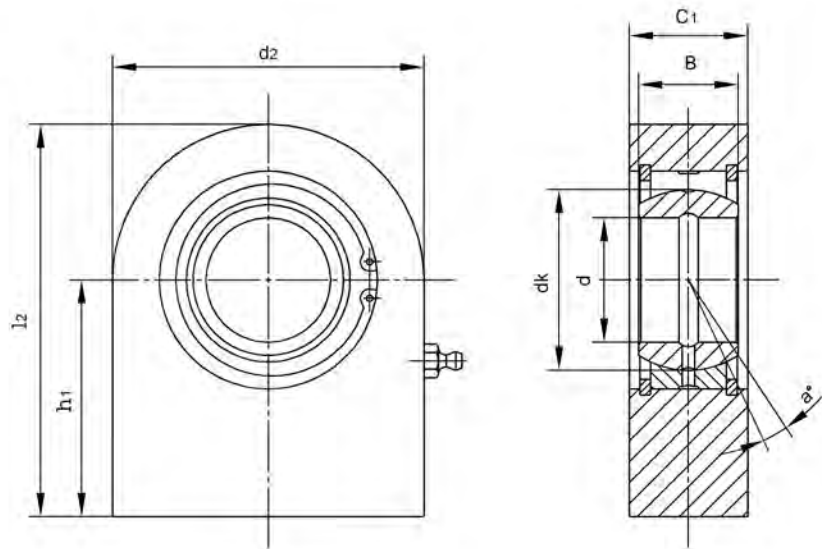

Bearing No.	Dimensions(mm)							a° mis. angle	Load ratings (KN)		Weight ≈ kg
	d	B	dk	C ₁	d ₂	h ₁	(l ₂)		Dynamic	Static	
SF20ES	20	16	29	19	50	38	63	9	30	67	0.36
SF25ES	25	20	35.5	23	55	45	72.5	7	48	69	0.53
SF30ES	30	22	40.7	28	65	51	83.5	6	62	118	0.85
SF35ES	35	25	47	30	83	61	102.5	6	79	196	1.5
SF40ES	40	28	53	35	100	69	119	7	99	305	2.42
SF45ES	45	32	60	40	110	77	132	7	127	386	3.39
SF50ES	50	35	66	40	123	88	149.5	6	156	441	4.24
SF60ES	60	44	80	50	140	100	170	6	245	570	7.10
SF70ES	70	49	92	55	164	115	197	6	313	724	10.7
SF80ES	80	55	105	60	180	141	231	6	400	804	15.1
SF90ES	90	60	115	65	226	150	263	5	488	1340	23.4
SF100ES	100	70	130	70	250	170	295	7	607	1516	33.1
SF110ES	110	70	140	80	295	185	332.5	6	654	2340	48.5
SF120ES	120	85	160	90	360	210	390	6	950	3210	79.5

SIR..ES

Body: Mild steel

SIR..ES: Mounted with GE..ES type of radial spherical plain bearings.

Sliding contact surfaces: Steel/Steel

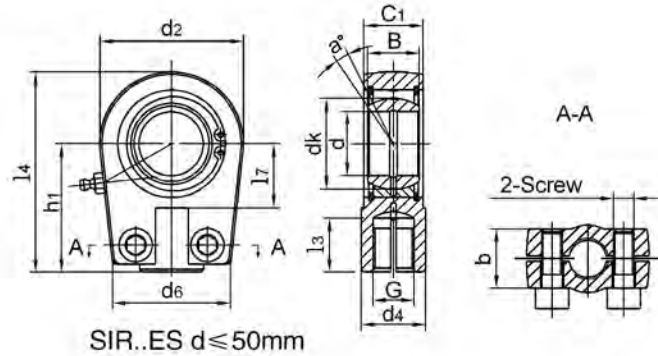

Body: Mild steel

SIR..ES: Mounted with GE..ES type of radial spherical plain bearings.

Sliding contact surfaces: Steel/Steel

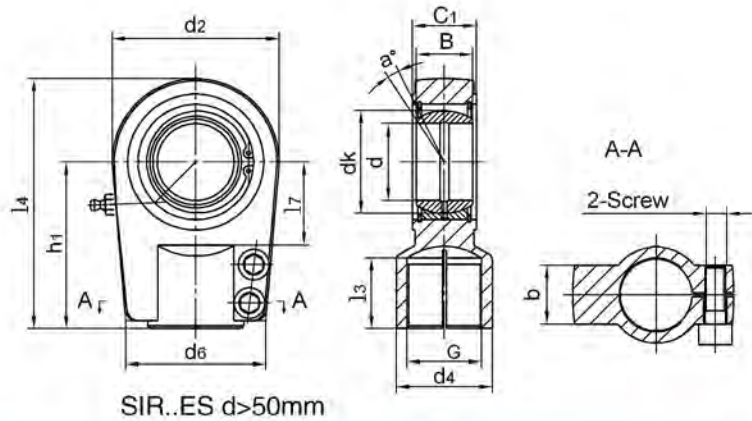

Bearing No.	Dimensions(mm)													a° mis. angle	Load ratings (KN)		Screw	Weight ≈ kg
	d	B	dk	C1	d2	G-6H	h1	l3	l4	l7	d4	d6	b		Dynamic	Static		
SIR20ES	20	16	29	19	56	M16x1.5	50	17	78	25	25	46	17	9	30	81	M8x16	0.44
SIR25ES	25	20	35.5	23	56	M16x1.5	50	17	78	25	25	46	21	7	48	72	M8x20	0.47
SIR30ES	30	22	40.7	28	64	M22x1.5	60	23	92	30	32	50	26	6	62	106	M8x25	0.77
SIR35ES	35	25	47	30	78	M28x1.5	70	29	109	38	40	66	28	6	79	153	M10x30	1.24
SIR40ES	40	28	53	35	94	M35x1.5	85	36	132	45	49	76	33	7	99	250	M10x35	2.12
SIR50ES	50	35	66	40	116	M45x1.5	105	46	163	55	61	90	37	7	156	365	M12x40	3.74
SIR60ES	60	44	80	50	130	M58x1.5	130	59	195	65	75	120	46	6	245	400	M16x45	6.49
SIR70ES	70	49	92	55	154	M65x1.5	150	66	227	75	86	130	51	6	313	540	M16x50	9.88
SIR80ES	80	55	105	60	176	M80x2	170	81	258	80	105	160	55	6	400	670	M20x55	14.2
SIR90ES	90	60	115	65	206	M100x2	210	101	313	90	124	180	60	5	488	980	M20x60	20.0
SIR100ES	100	70	130	70	231	M110x2	235	111	350.5	105	138	200	65	7	607	1120	M24x65	27.5
SIR110ES	110	70	140	80	266	M120x3	265	125	398	115	152	220	74	6	654	1700	M24x80	45.6
SIR120ES	120	85	160	90	340	M130x3	310	135	480	140	172	257	84	6	950	2900	M27x85	72

Can supply rod ends with maintenance-free spherical bearing.
for left-hand thread, suffix " L " is added to bearings number
and thread sign, e.g. SILR40ES M35x1.5L-6H

SIGEW..ES

Body: Mild steel

SIGEW..ES: Mounted with GEEW..ES type of radial spherical plain bearings.

Sliding contact surfaces: Steel/Steel

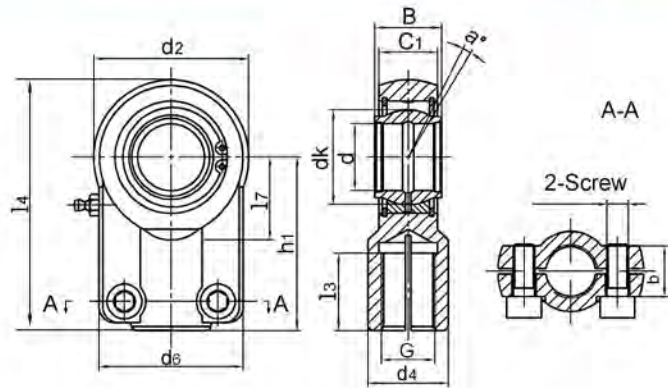

SIGEW..ES $d \leq 50\text{mm}$

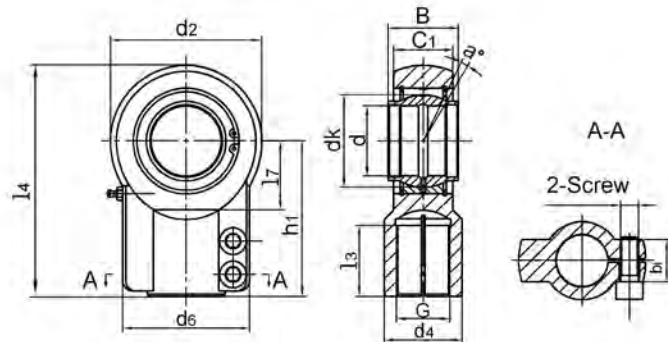

SIGEW..ES $d > 50\text{mm}$

Bearing No.	Dimensions(mm)													a° mis. angle	Load ratings (KN)		Screw	Weight ≈ kg
	d	B	dk	C1	d2	G-6H	h1	l3	(l4)	l7	d4	d6	b		Dynamic	Static		
SIGEW12ES ¹⁾	12	12	18	11	32	M12x1.25	38	17	54	14	16	32	11	4	10	24.5	M5x12	0.11
SIGEW16ES ²⁾	16	16	23	13	40	M14x1.5	44	19	64	20	21	40	13	4	17	36.5	M6x12	0.20
SIGEW20ES	20	20	29	17	47	M16x1.5	52	23	75.5	22	25	47	17	4	30	48	M8x20	0.35
SIGEW25ES	25	25	35.5	22	58	M20x1.5	65	29	94	27	30	54	19	4	48	78	M8x20	0.62
SIGEW32ES	32	32	43	28	71	M27x2	80	37	115.5	32	38	66	22	4	65	114	M10x30	1.15
SIGEW40ES	40	40	53	33	90	M33x2	97	46	142	41	47	80	26	4	99	204	M12x35	2.18
SIGEW50ES	50	50	66	41	109	M42x2	120	57	174.5	50	58	96	32	4	156	310	M16x40	3.96
SIGEW63ES	63	63	83	53	136	M48x2	140	64	208	62	70	114	38	4	253	430	M16x40	6.8
SIGEW70ES	70	70	92	57	155	M56x2	160	76	237.5	70	80	135	42	4	313	540	M16x40	9.6
SIGEW80ES	80	80	105	67	170	M64x3	180	86	265	78	90	148	48	4	400	695	M20x50	13.0
SIGEW90ES	90	90	115	72	185	M72x3	195	91	287.5	85	100	160	52	4	488	750	M20x60	19.1
SIGEW100ES	100	100	130	85	211	M80x3	210	96	315.5	98	110	178	62	4	607	1060	M24x60	25.0
SIGEW110ES	110	110	140	88	235	M90x3	235	106	352.5	105	125	190	62	4	654	1200	M24x60	32.0
SIGEW125ES	125	125	160	103	265	M100x3	260	113	392.5	120	135	200	72	4	950	1430	M24x70	46.0
SIGEW160ES	160	160	200	130	326	M125x4	310	126	473	150	165	250	82	4	1360	2200	M24x80	82.5
SIGEW200ES	200	200	250	162	418	M160x4	390	161	599	195	215	320	102	4	2120	3650	M30x100	168

¹⁾ Can only be relubricated through the rod end housing

²⁾ Can supply rod ends with maintenance-free spherical bearing.
for left-hand thread, suffix " L " is added to bearings number
and thread sign, e.g. SIGEW40ES M33x2L-6H

SIQ..ES

Body: Mild steel

SIQ..ES: Mounted with GE..ES type of radial spherical plain bearings.

Sliding contact surfaces: Steel/Steel

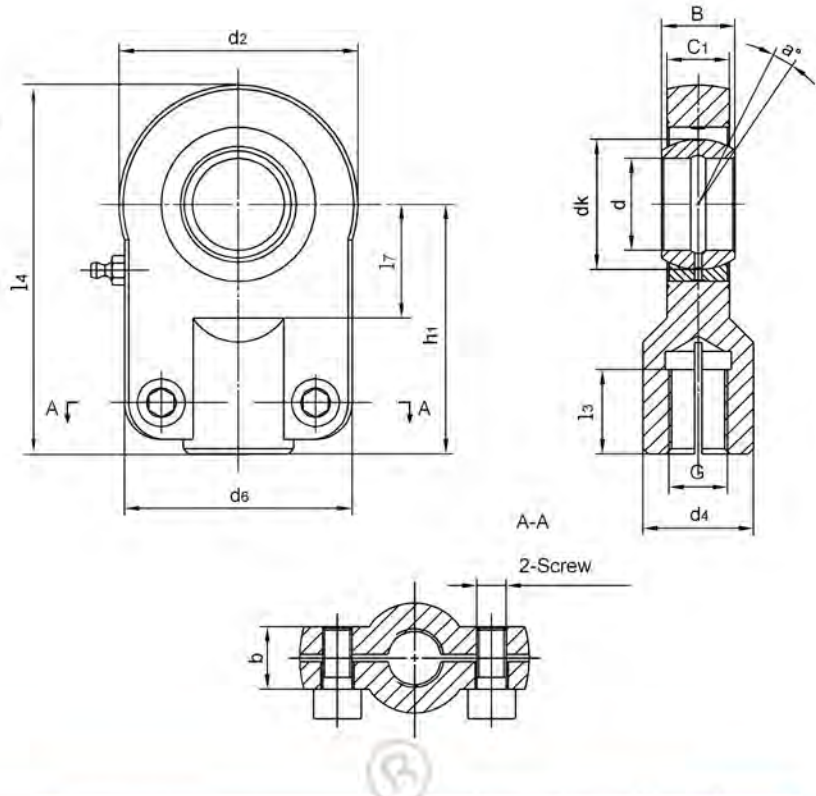

Bearing No	Dimensions(mm)													a° mis. angle	Load ratings (KN)		Screw	Weight ≈ kg
	d	B	dk	C1	d2	G-6H	h1	l3	l4	l7	d4	d6	b		Dynamic	Static		
	SIQ12ES ¹⁾	12	10	18	8	35	M10x1.25	42	15	59.5	16	17	35		13	10		
SIQ16ES ²⁾	16	14	25	11	45	M12x1.25	48	17	70.5	20	21	45	13	10	21	28.5	M6x12	0.22
SIQ20ES	20	16	29	13	55	M16x1.5	58	19	85.5	25	25	55	17	9	30	42.5	M8x16	0.43
SIQ25ES	25	20	35.5	17	65	M16x1.5	68	23	100.5	31	30	62	17	7	48	67	M8x16	0.67
SIQ30ES	30	22	40.7	19	80	M22x1.5	85	29	125	35	36	77	19	6	62	108	M10x20	1.25
SIQ40ES	40	28	53	23	100	M35x1.5	105	37	165	45	45	90	23	7	99	156	M10x25	2.16
SIQ50ES	50	35	66	30	120	M45x1.5	130	46	190	58	55	105	30	6	156	245	M12x30	3.90
SIQ60ES	60	44	80	38	160	M58x1.5	150	57	230	68	68	134	38	6	245	380	M16x40	7.15
SIQ80ES	80	55	105	47	205	M80x2	185	64	287.5	82	90	156	47	6	400	585	M20x50	15
SIQ100ES	100	70	130	55	240	M110x2	240	86	360	116	110	190	55	7	607	865	M24x60	27.3

¹⁾Can not be relubricated

²⁾Can only be relubricated through the rod end housing
 Can supply rod ends with maintenance-free spherical bearing.
 for left-hand thread, suffix " L " is added to bearings number
 and thread sign, e.g.SILQ40ES M27x2L-6H

Special properties of LDK[®] all plastic Rod End Bearings

- Body and ball made of special plastic polymer (Patent ZL 2009 2 0031919.1)
- Maintenance free, self lubricating.
- High strength under impact loads.
- High tensile strength for varying loads.
- Compensation for alignment errors.
- Resistant to dirt and dust.
- Resistant to corrosion of chemicals.
- High vibration dampening capacity.
- Suitable for rotating, oscillating and linear movements.
- Very low weight.

Application Temperatures

LDK[®] bearing elements can be used in temperatures from - 30°C to + 80°C .Table1 shows the effect of temperature on the loading capacity of the LDK[®] bearing elements.

Application Temperatures

Minimum	- 30°C
Maximum,long term	+ 80°C
Maximum,short term	+ 120°C

Table 1:Applications temperatures

Chemical Resistance

The moisture absorption of LDK[®] is approximately 1.3% of weight standard atmosphere.The saturation limit in water is 6.5%. This must be taken into account for these types of applications. LDK[®] all plastic polymer are resistant to weak alkalines, weak acids and fuels, as well as all types of lubricants.

Medium Resistance

Medium	Resistance
Alcohol	Resistant
Chlorinated hydrocarbons	Resistant
Ester	Not Resistant
Greases, oils	Resistant
Ketones	Conditionally Resistant
Fuels	Resistant
Weak acids	Conditionally Resistant
Strong acids	Not Resistant
Weak alkalines	Resistant
Strong alkalines	Conditionally Resistant

Table 2:Chemical resistance

UV Resistance

The corrosion resistance of the LDK[®] bearings give them special value for outside applications.

LDK[®] bearing elements are permanently resistant to UV radiation. A small change in colour (dark coloration) of the spherical ball due to UV radiation does not effect the mechanical, electrical or thermal properties.



Picture 1: Some models of the LDK[®] product line

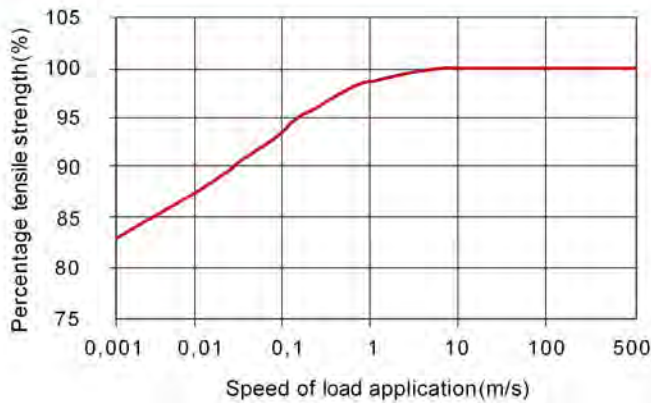

Table 3: Effect of the speed of load application on the maximum tensile strength of LDK[®] rod end bearings

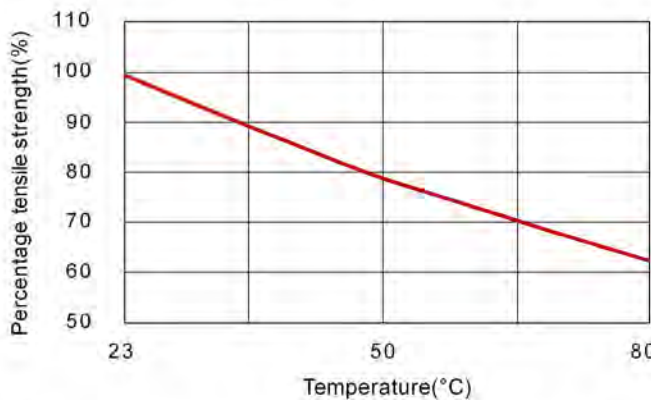

Table 4: Effect of the temperature on the maximum tensile strength of LDK[®] rod end bearings

Thread Name	Pitch [mm]
M2	0.40
M3	0.50
M4	0.70
M5	0.80
M6	1.00
M8	1.25
M10	1.50
M10F	1.25
M12	1.75
M12F	1.25
M14	2.00
M16	2.00
M16F	1.50
M18	1.50
M20	2.50
M20 M20	1.50
M22	1.50
M24	2.00
M27	2.00
M30	2.00

Table 5: Thread pitches of the LDK[®] rod end bearings

Loads

The load capacity of the maintenance free LDK[®] bearing elements is very high at normal ambient temperatures. LDK[®] bearing elements absorb high forces and weigh only a fifth of traditional, metal bearing housings. The excellent dampening properties are based on the fact that the polymer material of the two part bearing can absorb vibrations differently than steel.

However, plastic specific properties, such as dependence on temperature and behaviour under long term stress, must be taken into consideration when using LDK[®] bearings. The load capacity of the rod end bearing should therefore be checked in a performance test, particularly if they are to be used under continuous high loads and at elevated temperatures.

Coefficients of Sliding Friction and Speed

One important advantage of LDK[®] spherical bearings is that rapid, rotary movements of a mounted shaft take place directly in the spherical portion, made of special plastic polymer. In metallic rod ends, rotary motion takes place between the race and the spherical bearing. High speeds can be achieved with LDK[®] bearings.

LDK[®] bearings are used in such a way that the angular movements of the spherical bearings takes place at the outer diameter. In contrast, rotations of the shaft are supported directly in the I.D. of the spherical portion. The advantage, therefore, lies in the polymer vs. steel relationship. Polymer produces lower friction and permits high speeds, even when running dry.

Structure for Part Numbers for LDK[®] Rod End Bearings

The part numbers of LDK[®] rod end bearings are designed according to the following system:

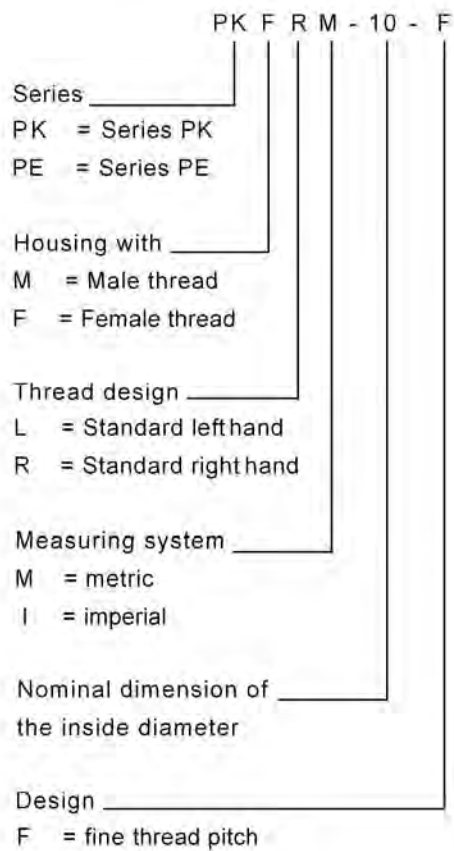

The example given is the number for a rod end bearing of the dimensional series PK with metric female right hand thread. The inner diameter of the spherical ball is 10 mm.



PKFM..

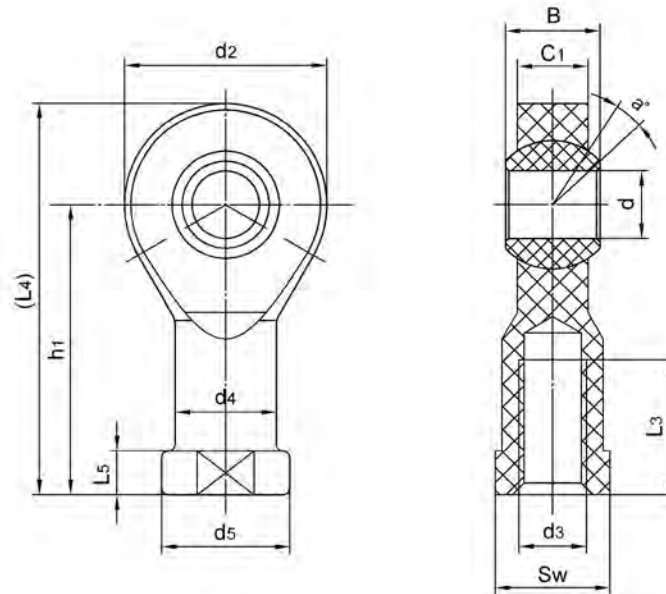

Bearing No.	Dimensions(mm)												Ball dia	a° mis. angle	Maximum Static Tensile Strength Short-Term(N)	weight ≈ 9
	d E10	d2	d3	d4	d5	C1	B	h1	L3	(L4)	L5	SW				
PKF(L)M-02	2	9	M2	4	4.6	3	4	12.5	6	17	2.5	4	5.2	15	200	1.8
PKF(L)M-03	3	13	M3	6.5	8	4.5	6	18.5	8	25	3	7	7.9	14	800	2.46
PKF(L)M-05M4	5	18	M4	9	12	6	8	27	10	36	4	9	11.1	13	1000	3.64
PKF(L)M-05	5	18	M5	9	12	6	8	27	10	36	4	9	11.1	13	1000	3.52
PKF(L)M-06	6	20	M6	10	13	7	9	30	12	40	5	11	12.7	11	1400	5.03
PKF(L)M-08	8	24	M8	13	16	9	12	36	16	48	5	14	15.8	14	2100	9.18
PKF(L)M-10	10	30	M10	15	19	10.5	14	43	20	58	6.5	17	19	13	3100	15.68
PKF(L)M-10 F	10	30	M10x1.25	15	19	10.5	14	43	20	58	6.5	17	19	13	3100	15.68
PKF(L)M-12	12	34	M12	18	22	12	16	50	22	67	6.5	19	22.2	13	3600	23.75
PKF(L)M-12 F	12	34	M12x1.25	18	22	12	16	50	22	67	6.5	19	22.2	13	3600	23.75
PKF(L)M-14	14	38	M14	20	25	13.5	19	57	25	76	8	22	25.25	16	4000	33.06
PKF(L)M-16	16	42	M16	22	27	15	21	64	28	85	8	22	28.3	15	4200	41.76
PKF(L)M-16 F	16	42	M16x1.5	22	27	15	21	64	28	85	8	22	28.3	15	4200	41.76
PKF(L)M-18	18	46	M18x1.5	25	31	16.5	23	71	32	94	10	27	31.35	15	4600	58.92
PKF(L)M-20	20	50	M20	28	34	18	25	77	33	102	10	30	34.9	14	5400	78.1
PKF(L)M-20 M20	20	50	M20x1.5	28	34	18	25	77	33	102	10	30	34.9	14	5400	76.95
PKF(L)M-22	22	56	M22x1.5	30	37	20	28	84	37	112	12	32	38.1	15	7000	102.3
PKF(L)M-25	25	60	M24x2.0	32	41	22	31	94	42	124	12	36	42.8	15	8500	129
PKF(L)M-30	30	70	M30x2.0	37	50	25	37	110	51	145	15	41	51	15	10500	197.5

For left-hand thread, suffix"L" is added to bearing numbers. eg.: PKFLM20 M20x1.5L

PKMM..

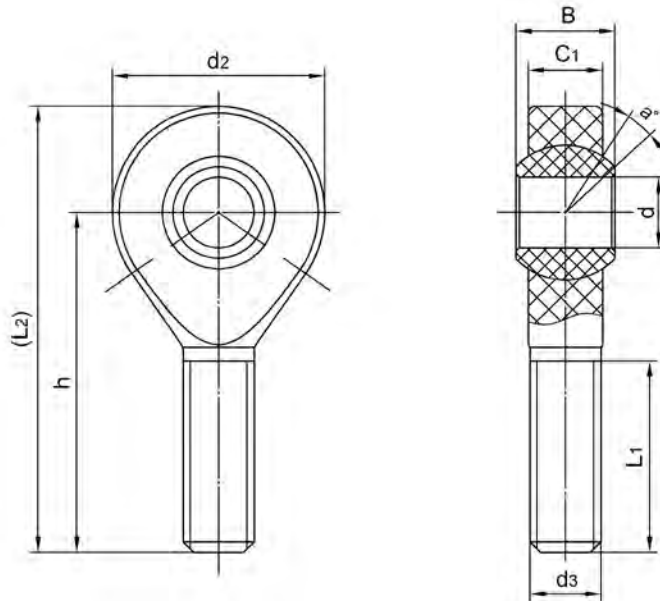

Bearing No.	Dimensions(mm)								Ball dia	a° mis. angle	Maximum Static Tensile Strength Short-Term(N)	weight ≈ g
	d E10	d2	d3	C1	B	h	L1	L2				
PKM(L)M-05	5	18	M05	6	8	33	19	42	11.1	13	800	2.64
PKM(L)M-06	6	20	M06	7	9	36	21	46	12.7	11	1000	3.87
PKM(L)M-08	8	24	M08	9	12	42	25	54	15.8	14	1700	7.2
PKM(L)M-10	10	30	M10	10.5	14	48	28	63	19	13	2500	13
PKM(L)M-10 F	10	30	M10x1.25	10.5	14	48	28	63	19	13	2500	13.11
PKM(L)M-12	12	34	M12	12.0	16	54	32	71	22.2	13	2700	19.2
PKM(L)M-12 F	12	34	M12x1.25	12.0	16	54	32	71	22.2	13	2700	19.4
PKM(L)M-14	14	38	M14	13.5	19	61	36	80	25.25	16	3400	27.4
PKM(L)M-16	16	42	M16	15.0	21	66	37	87	28.3	15	3900	37.4
PKM(L)M-16 F	16	42	M16x1.5	15.0	21	66	37	87	28.3	15	3900	38
PKM(L)M-18	18	46	M18x1.5	16.5	23	72	41	95	31.35	15	4200	49.8
PKM(L)M-20	20	50	M20x2.5	18	25	78	45	103	34.9	14	6000	64.5
PKM(L)M-20 M20	20	50	M20x1.5	18	25	78	45	103	34.9	14	6000	65.78
PKM(L)M-22	22	56	M22x1.5	20	28	84	48	112	38.1	15	7200	89.84
PKM(L)M-25	25	60	M24x2.0	22	31	94	55	124	42.8	15	7500	114.1
PKM(L)M-30	30	70	M30x2.0	25	37	110	66	145	51	15	8800	188.1

For left-hand thread, suffix "L" is added to bearing numbers. eg.: PKMLM20 M20x1.5L

PEFM..

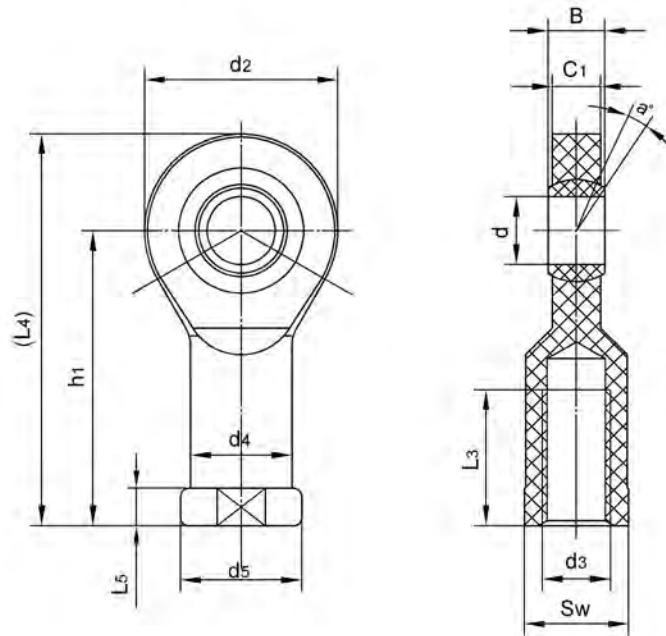

Bearing No.	Dimensions(mm)												Ball dia	a° mis. angle	Maximum Static Tensile Strength Short-term(N)	weight ≈ g
	d _{E10}	d2	d3	d4	d5	C1	B	h1	L3	(L4)	L5	SW				
PEF(L)M-04	4	15	M4	8	9.2	3.5	5	22.5	9.5	30	4	8	8.2	12	800	1.85
PEF(L)M-05	5	19	M5	9	11	4.4	6	30	12	39.5	5	9	10.2	10	1300	3.44
PEF(L)M-06	6	21	M6	11	13	4.4	6	30	12	40.5	5	11	10.2	10	1500	4.41
PEF(L)M-08	8	24	M8	13	16	6	8	36	16	48	5	14	13.2	10	2000	7.4
PEF(L)M-10	10	29	M10	15	19	7	9	43	18	57.5	6.5	17	16	8	2300	12.1
PEF(L)M-10 F	10	29	M10x1.25	15	19	7	9	43	18	57.5	6.5	17	16	8	2300	12
PEF(L)M-12	12	34	M12	18	22	8	10	50	20	67	7	19	18	7	3300	19
PEF(L)M-12 F	12	34	M12x1.25	18	22	8	10	50	20	67	7	19	18	7	3300	18.7
PEF(L)M-15	15	40	M14	21	26	10	12	61	26	81	8	22	22	6	4800	32.7
PEF(L)M-17	17	46	M16	24	30	11	14	67	27	90	10	27	25.4	7	5300	46.8
PEF(L)M-17 F	17	46	M16x1.5	24	30	11	14	67	27	90	10	27	25.4	7	5300	46.4
PEF(L)M-20	20	53	M20x2.5	27	34	13	16	77	31	103.5	10	30	28.9	6	7200	68.9
PEF(L)M-20 M-20	20	53	M20x1.5	27	34	13	16	77	31	103.5	10	30	28.9	6	7200	67.9
PEF(L)M-25	25	64	M24x2.0	34	41	17	20	94	38	126	12	36	35.5	5	10000	130
PEF(L)M-30	30	73	M30x2.0	41	48	19	22	110	47	146.5	15	41	40.9	4	10500	195.1

For left-hand thread, suffix "L" is added to bearing numbers. eg.: PEFLM20 M20x1.5L

PEMM..

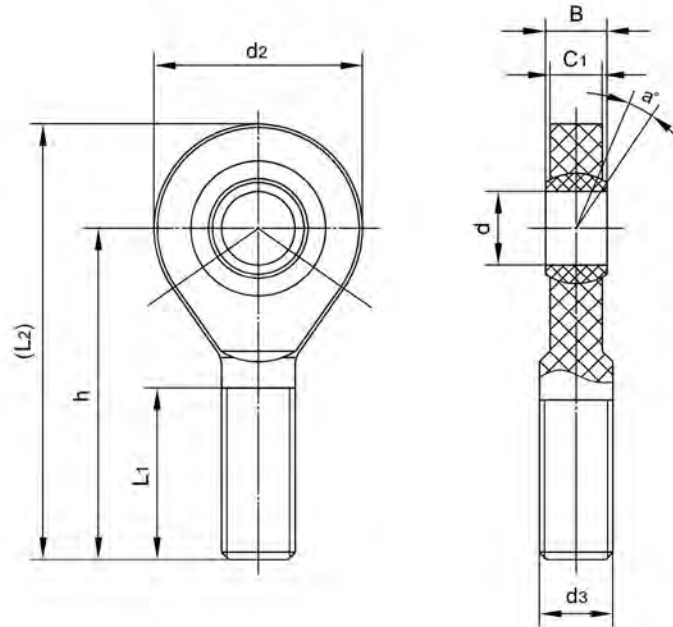

Bearing No.	Dimensions(mm)								Ball dia	a° mis. angle	Maximum Static Tensile Strength Short-term(N)	weight ≈ g
	d E10	d2	d3	C1	B	h	L1	L2				
PEM(L)M-05	5	19	M5	4.4	6	36	20	45.5	10.2	10	550	2.24
PEM(L)M-06	6	21	M6	4.4	6	36	20	46.5	10.2	10	850	2.65
PEM(L)M-08	8	24	M8	6.0	8	41	24	53.0	13.2	10	1600	2.98
PEM(L)M-10	10	29	M10	7.0	9	47.5	27	62.0	16	8	2600	9.12
PEM(L)M-10 F	10	29	M10x1.25	7.0	9	47.5	27	62.0	16	8	2600	9.2
PEM(L)M-12	12	34	M12	8.0	10	54	29	71.0	18	7	3000	14.3
PEM(L)M-12 F	12	34	M12x1.25	8.0	10	54	29	71.0	18	7	3000	14.7
PEM(L)M-15	15	40	M14	10.0	12	63	34	83.0	22	6	4500	23.9
PEM(L)M-17	17	46	M16	11.0	14	69	37	92.0	25.4	7	5000	34.87
PEM(L)M-17 F	17	46	M16x1.5	11.0	14	69	37	92.0	25.4	7	5000	35.4
PEM(L)M-20	20	53	M20x2.5	13.0	16	80	43	106.5	28.9	6	6500	57.04
PEM(L)M-20 M20	20	53	M20x1.5	13.0	16	80	43	106.5	28.9	6	6500	58.24
PEM(L)M-25	25	64	M24x2.0	17.0	20	97	53	129.0	35.5	5	8500	107.1
PEM(L)M-30	30	73	M30x2.0	19.0	22	113	65	149.5	40.9	4	10000	169.3

For left-hand thread, suffix "L" is added to bearing numbers. eg.: PEMLM20 M20x1.5L

PKFI..

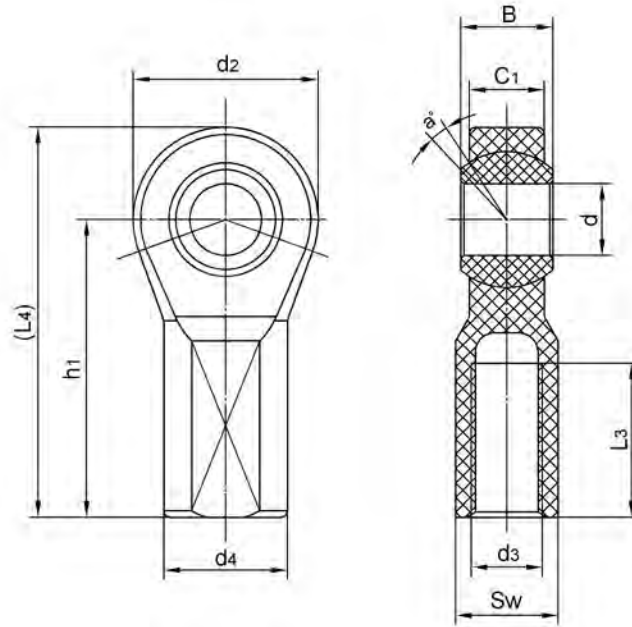

Bearing No.	Dimensions(mm/inch)										Ball dia	a° mis. angle	Maximum Static Tensile Strength Short-term(N)	weight ≈ g
	d E10	d2	d3	d4	C1	B	h1	L3	(L4)	SW				
PKF(L)I-03	4.826	15.88	10-32	10.31	6.25	7.93	26.97	12.7	34.9	7.92	11.28	10	900	3.3
	0.1900	0.625		0.406	0.246	0.312	1.062	0.500	1.374	0.312	0.444			
PKF(L)I-04	6.35	19.05	1/4-28	11.91	6.9	9.27	33.33	17.45	42.85	9.53	13.1	13	1100	5.3
	0.2500	0.750		0.469	0.272	0.365	1.312	0.687	1.687	0.375	0.516			
PKF(L)I-05	7.937	22.23	5/16-24	12.7	8.64	11.1	34.93	17.45	46.05	11.1	15.88	11	1700	7.3
	0.3125	0.875		0.500	0.340	0.437	1.375	0.687	1.813	0.437	0.625			
PKF(L)I-06	9.525	25.4	3/8-24	17.45	10	12.7	41.28	20.63	53.98	14.27	18.24	10	2000	13.2
	0.3750	1.000		0.687	0.394	0.500	1.625	0.812	2.125	0.562	0.718			
PKF(L)I-07	11.112	28.58	7/16-20	19.05	11.58	14.27	46.02	23.8	60.3	15.88	21.03	9	2300	18.1
	0.4375	1.125		0.750	0.456	0.562	1.812	0.937	2.374	0.625	0.828			
PKF(L)I-08	12.7	33.33	1/2-20	22.23	12.37	15.88	56.26	26.97	72.93	19.05	24.96	9	2600	29.2
	0.5000	1.312		0.875	0.487	0.625	2.215	1.062	2.781	0.750	0.938			
PKF(L)I-10	15.875	38.1	5/8-18	25.4	13.84	19.05	63.5	34.93	82.55	22.23	28.58	12	4900	40.1
	0.6250	1.500		1.000	0.545	0.750	2.500	1.375	3.250	0.875	1.125			
PKF(L)I-12	19.05	44.45	3/4-16	28.58	17.17	22.23	73.03	39.67	95.25	25.4	33.33	10	5600	61.2
	0.7500	1.750		1.125	0.676	0.875	2.875	1.562	3.750	1.000	1.312			
PKF(L)I-16	25.4	69.85	1-12	41.28	25.4	34.93	104.78	53.98	139.7	38.1	50.8	13	6000	223.1
	1.0000	2.750		1.625	1.000	1.375	4.125	2.125	5.500	1.500	2.000			

For left-hand thread, suffix "L" is added to bearing numbers. eg.: PKFLM20 M20x1.5L

PKMI..

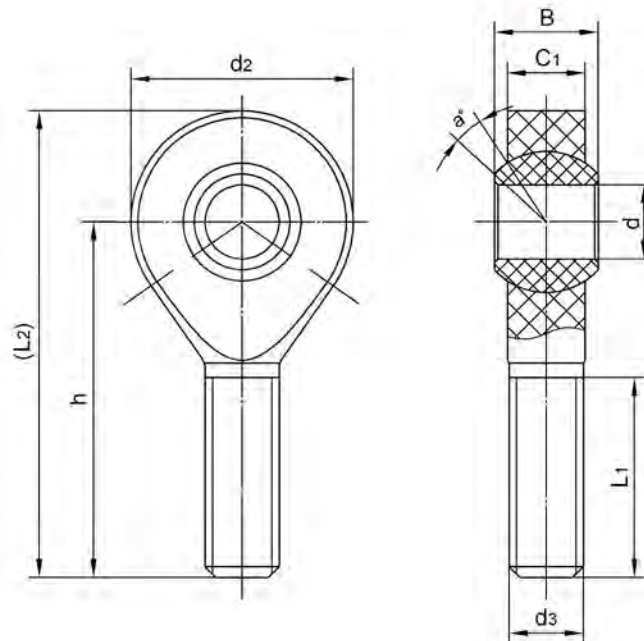

Bearing No.	Dimensions(mm/inch)								Ball dia	a° mis. angle	Maximum Static Tensile Strength Short-term(N)	weight ≈ g
	d E10	d2	d3	C-1	B	h	L1	L2				
PKM(L)-03	4.826	15.88	10-32	5.94	7.93	31.75	19.05	39.7	11.28	12	390	2.2
	0.1900	0.625		0.234	0.312	1.250	0.750	1.563	0.444			
PKM(L)-04	6.35	19.05	1/4-28	6.35	9.27	39.68	25.4	49.2	13.1	16	900	3.7
	0.2500	0.750		0.250	0.365	1.562	1.000	1.937	0.516			
PKM(L)-05	7.937	22.23	5/16-24	7.92	11.1	47.63	31.75	58.75	15.88	14	1100	6.4
	0.3125	0.875		0.312	0.437	1.875	1.250	2.313	0.625			
PKM(L)-06	9.525	25.4	3/8-24	9.12	12.7	49.23	31.75	61.93	18.24	14	1500	9.5
	0.3750	1.000		0.359	0.500	1.938	1.250	2.438	0.718			
PKM(L)-07	11.112	28.58	7/16-20	10.31	14.27	53.98	34.93	68.28	21.03	13	2000	13.6
	0.4375	1.125		0.406	0.562	2.125	1.375	2.688	0.828			
PKM(L)-08	12.7	33.33	1/2-20	11.51	15.88	61.67	38.1	78.34	24.96	12	2500	20.7
	0.5000	1.250		0.453	0.625	2.428	1.500	3.084	0.938			
PKM(L)-10	15.875	38.1	5/8-18	12.3	19.05	66.68	41.28	85.73	28.58	16	3500	29.9
	0.6250	1.500		0.484	0.750	2.625	1.625	3.375	1.125			
PKM(L)-12	19.05	44.45	3/4-16	15.06	2.23	73.03	44.45	95.25	33.33	14	3900	48.8
	0.7500	1.750		0.539	0.875	2.875	1.750	3.750	1.312			
PKM(L)-16	25.4	69.85	1-12	25.4	34.93	104.78	59.7	139.7	50.8	13	4400	170.6
	1.0000	2.750		1.000	1.375	4.125	2.350	5.500	2.000			

For left-hand thread, suffix "L" is added to bearing numbers. eg.: PKML12 3/4-16L

**GE..E
GE..ES
GE..ES-2RS**

Inner Race: Gcr15 Steel,hardened HRC 58-64,
surface phosphated.

Outer Race: Gcr15 Steel,hardened HRC 54-60,
surface phosphated.

Bore size $d \geq 140\text{mm}$: Inner and outer race are all Gcr15 SiMn.

Sliding contact surfaces: Steel/Steel

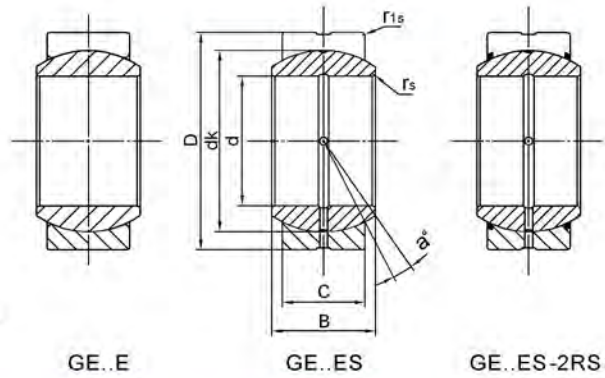

Bearing No.		Dimensions(mm)							Load ratings KN		a° ≈	weight ≈ kg
		d	D	B	C	dk	rs	r1s	Dynamic	Static		
GE4E		4	12	5	3	8	0.3	0.3	2	10	16	0.003
GE5E		5	14	6	4	10	0.3	0.3	3.4	17	13	0.005
GE6E		6	14	6	4	10	0.3	0.3	3.4	17	13	0.004
GE8E		8	16	8	5	13	0.3	0.3	5.5	27	15	0.008
GE10E		10	19	9	6	16	0.3	0.3	8.1	40	12	0.011
GE12E		12	22	10	7	18	0.3	0.3	10	53	10	0.015
GE15ES	GE15ES-2RS	15	26	12	9	22	0.3	0.3	16	84	8	0.027
GE17ES	GE17ES-2RS	17	30	14	10	25	0.3	0.3	21	106	10	0.041
GE20ES	GE20ES-2RS	20	35	16	12	29	0.3	0.3	30	146	9	0.066
GE25ES	GE25ES-2RS	25	42	20	16	35.5	0.6	0.6	48	240	7	0.119
GE30ES	GE30ES-2RS	30	47	22	18	40.7	0.6	0.6	62	310	6	0.153
GE35ES	GE35ES-2RS	35	55	25	20	47	0.6	1	79	399	6	0.233
GE40ES	GE40ES-2RS	40	62	28	22	53	0.6	1	99	495	7	0.306
GE45ES	GE45ES-2RS	45	68	32	25	60	0.6	1	127	637	7	0.427
GE50ES	GE50ES-2RS	50	75	35	28	66	0.6	1	156	780	6	0.546
GE55ES	GE55ES-2RS	55	85	40	32	74	0.6	1	200	1000	7	0.939
GE60ES	GE60ES-2RS	60	90	44	36	80	1	1	245	1220	6	1.04
GE70ES	GE70ES-2RS	70	105	49	40	92	1	1	313	1560	6	1.55
GE80ES	GE80ES-2RS	80	120	55	45	105	1	1	400	2000	6	2.31
GE90ES	GE90ES-2RS	90	130	60	50	115	1	1	488	2440	5	2.75
GE100ES	GE100ES-2RS	100	150	70	55	130	1	1	607	3030	7	4.45
GE110ES	GE110ES-2RS	110	160	70	55	140	1	1	654	3270	6	4.82
GE120ES	GE120ES-2RS	120	180	85	70	160	1	1	950	4750	6	8.05
GE140ES	GE140ES-2RS	140	210	90	70	180	1	1	1070	5350	7	11.02
GE160ES	GE160ES-2RS	160	230	105	80	200	1	1	1360	6800	8	14.01
GE180ES	GE180ES-2RS	180	260	105	80	225	1.1	1.1	1530	7650	6	18.65
GE200ES	GE200ES-2RS	200	290	130	100	250	1.1	1.1	2120	10600	7	28.03
GE220ES	GE220ES-2RS	220	320	135	100	275	1.1	1.1	2320	11600	8	35.51
GE240ES	GE240ES-2RS	240	340	140	100	300	1.1	1.1	2550	12700	8	39.91
GE260ES	GE260ES-2RS	260	370	150	110	325	1.1	1.1	3030	15190	7	51.54
GE280ES	GE280ES-2RS	280	400	155	120	350	1.1	1.1	3570	17850	6	65.06
GE300ES	GE300ES-2RS	300	430	165	120	375	1.1	1.1	3800	19100	7	78.07

GEZ..ES GEZ..ES-2RS

Inner Race: Gcr15 Steel, hardened HRC 58-64, surface phosphated.

Outer Race: Gcr15 Steel, hardened HRC 54-60, surface phosphated.

Bore size $d \geq 140\text{mm}$: Inner and outer race are all Gcr15 SiMn.

Sliding contact surfaces: Steel/Steel

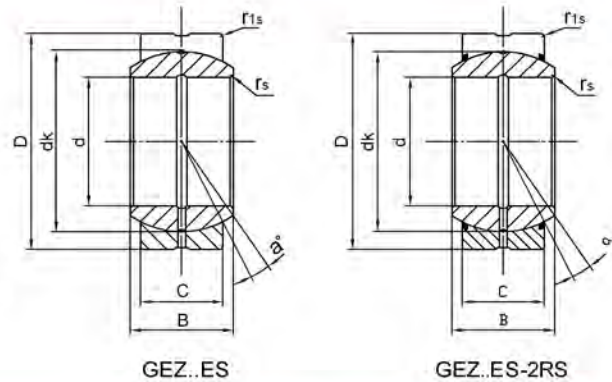

Bearing No.		Dimensions(mm/inch)							Load ratings KN		α° ≈	weight ≈ kg
		d	D	B	C	dk	rs	r1s	Dynamic	Static		
GEZ12ES		12.700	22.225	11.100	9.525	18	0.15	0.6	13	41	6	0.022
		0.5	0.875	0.437	0.375	0.707	0.006	0.024				
GEZ15ES		15.875	26.988	13.894	11.913	23	0.15	0.6	22	65	6	0.036
		0.625	1.0625	0.547	0.469	0.904	0.006	0.024				
GEZ19ES		19.050	31.750	16.662	14.275	27.5	0.3	0.6	31	95	6	0.053
		0.75	1.25	0.656	0.562	1.081	0.012	0.024				
GEZ22ES		22.225	36.513	19.431	16.662	32	0.3	0.6	42	127	6	0.085
		0.875	1.4375	0.756	0.656	1.258	0.012	0.024				
GEZ25ES	GEZ25ES-2RS	25.400	41.275	22.225	19.050	36.5	0.3	0.6	56	166	6	0.121
		1	1.625	0.875	0.75	1.437	0.012	0.024				
GEZ31ES	GEZ31ES-2RS	31.750	50.800	27.762	23.800	45.5	0.6	0.6	86	260	6	0.23
		1.25	2	1.093	0.937	1.788	0.024	0.024				
GEZ34ES	GEZ34ES-2RS	34.925	55.563	30.150	26.187	49	0.6	1	102	310	6	0.35
		1.375	2.1875	1.187	1.031	1.926	0.024	0.04				
GEZ38ES	GEZ38ES-2RS	38.100	61.913	33.325	28.575	54.7	0.6	1	125	375	6	0.42
		1.5	2.4375	1.312	1.125	2.154	0.024	0.04				
GEZ44ES	GEZ44ES-2RS	44.450	71.438	38.887	33.325	63.9	0.6	1	170	510	6	0.64
		1.75	2.8125	1.531	1.312	2.511	0.024	0.04				
GEZ50ES	GEZ50ES-2RS	50.800	80.963	44.450	38.100	73	0.6	1	224	670	6	0.93
		2	3.1875	1.75	1.5	2.869	0.024	0.04				
GEZ57ES	GEZ57ES-2RS	57.150	90.488	50.013	42.850	82	0.6	1	280	850	6	1.3
		2.25	3.5625	1.969	1.687	3.223	0.024	0.04				
GEZ63ES	GEZ63ES-2RS	63.500	100.013	55.550	47.625	92	1	1	355	1060	6	1.85
		2.5	3.9375	2.187	1.875	3.616	0.04	0.04				
GEZ69ES	GEZ69ES-2RS	69.850	111.125	61.112	52.375	100	1	1	415	1250	6	2.4
		2.75	4.375	2.406	2.062	3.937	0.04	0.04				
GEZ76ES	GEZ76ES-2RS	76.200	120.650	66.675	57.150	109.5	1	1	500	1500	6	3.1
		3	4.75	2.625	2.25	4.303	0.04	0.04				
GEZ82ES	GEZ82ES-2RS	82.550	130.175	72.238	61.900	119	1	1	585	1760	6	3.8
		3.25	5.125	2.844	2.437	4.685	0.04	0.04				
GEZ88ES	GEZ88ES-2RS	88.900	139.700	77.775	66.675	128	1	1	680	2040	6	4.8
		3.5	5.5	3.062	2.625	5.04	0.04	0.04				

**GEZ..ES
GEZ..ES-2RS**

Inner Race: Gcr15 Steel, hardened HRC 58-64, surface phosphated.

Outer Race: Gcr15 Steel, hardened HRC 54-60, surface phosphated.

Bore size $d \geq 140$ mm: Inner and outer race are all Gcr15 SiMn.

Sliding contact surfaces: Steel/Steel.

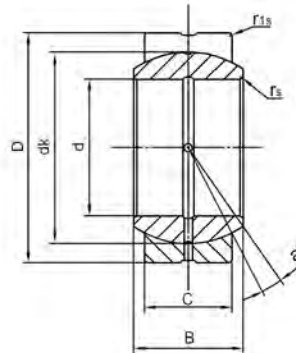

GEZ..ES

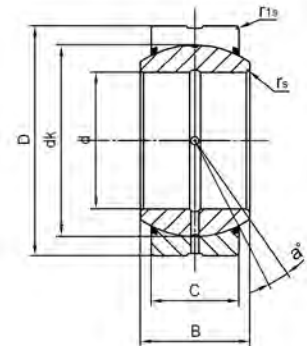

GEZ..ES-2RS

Bearing No.		Dimensions(mm/inch)							Load ratings KN		a° ≈	weight ≈ kg
		d	D	B	C	dk	fs min	r1s min	Dynamic	Static		
GEZ88ES	GEZ88ES-2RS	88.9	139.7	77.775	66.675	128	1.0	1.0	680	2040	6	4.8
		3.5	5.5	3.062	2.625	5.04	0.04	0.04				
GEZ95ES	GEZ95ES-2RS	95.25	149.225	83.337	71.425	137	1.0	1.0	780	2360	6	5.8
		3.75	5.875	3.281	2.812	5.393	0.04	0.04				
GEZ101ES	GEZ101ES-2RS	101.600	158.750	88.900	76.200	146	1.0	1.0	900	2650	6	7
		4	6.25	3.5	3	5.748	0.04	0.04				
GEZ107ES	GEZ107ES-2RS	107.950	168.275	94.463	80.950	155	1.0	1.0	1000	3000	6	8.41
		4.25	6.625	3.719	3.187	6.102	0.04	0.04				
GEZ114ES	GEZ114ES-2RS	114.300	177.800	100.013	85.725	164.5	1.0	1.0	1120	3400	6	9.8
		4.5	7	3.937	3.375	6.476	0.04	0.04				
GEZ120ES	GEZ120ES-2RS	120.650	187.325	105.562	90.475	173.5	1.0	1.0	1250	3750	6	11.5
		4.75	7.375	4.156	3.562	6.83	0.04	0.04				
GEZ127ES	GEZ127ES-2RS	127.000	196.850	111.125	95.25	183	1.0	1.0	1400	4150	6	13.5
		5	7.75	4.375	3.75	7.204	0.04	0.04				
GEZ152ES	GEZ152ES-2RS	152.400	222.250	120.65	104.775	207	1.0	1.0	1730	5200	5	17.5
		6	8.75	4.75	4.125	8.15	0.04	0.04				

GEG..E GEG..ES GEG..ES-2RS

Inner Race: Gcr15 Steel, hardened HRC 58-64,
surface phosphated.

Outer Race: Gcr15 Steel, hardened HRC 54-60,
surface phosphated.

Bore size $d \geq 120\text{mm}$: Inner and outer race are all Gcr15 SiMn.

Sliding contact surfaces: Steel/Steel.

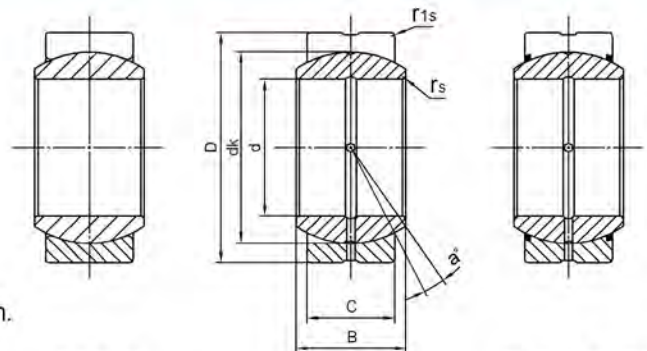

GEG..E

GEG..ES

GEG..ES-2RS

Bearing No.		Dimensions(mm)							Load ratings KN		a° ≈	weight ≈ kg
		d	D	B	C	dk	r _s	r _{1s}	Dynamic	Static		
GEG4E		4	14	7	4	10	0.3	0.3	3.4	17	20	0.005
GEG5E		5	16	9	5	13	0.3	0.3	5.5	27	21	0.008
GEG6E		6	16	9	5	13	0.3	0.3	5.5	27	21	0.006
GEG8E		8	19	11	6	16	0.3	0.3	8.1	40	21	0.014
GEG10E		10	22	12	7	18	0.3	0.3	10	53	18	0.021
GEG12E		12	26	15	9	22	0.3	0.3	16	84	18	0.033
GEG15ES	GEG15ES-2RS	15	30	16	10	25	0.3	0.3	21	106	16	0.049
GEG17ES	GEG17ES-2RS	17	35	20	12	29	0.3	0.3	30	146	19	0.083
GEG20ES	GEG20ES-2RS	20	42	25	16	35.5	0.3	0.6	48	240	17	0.153
GEG25ES	GEG25ES-2RS	25	47	28	18	40.7	0.6	0.6	62	310	17	0.203
GEG30ES	GEG30ES-2RS	30	55	32	20	47	0.6	1	79	399	17	0.304
GEG35ES	GEG35ES-2RS	35	62	35	22	53	0.6	1	99	495	16	0.408
GEG40ES	GEG40ES-2RS	40	68	40	25	60	0.6	1	127	637	17	0.542
GEG45ES	GEG45ES-2RS	45	75	43	28	66	0.6	1	156	780	15	0.713
GEG50ES	GEG50ES-2RS	50	90	56	36	80	0.6	1	245	1220	17	1.14
GEG60ES	GEG60ES-2RS	60	105	63	40	92	1	1	313	1560	17	2.05
GEG70ES	GEG70ES-2RS	70	120	70	45	105	1	1	400	2000	16	3.01
GEG80ES	GEG80ES-2RS	80	130	75	50	115	1	1	488	2440	14	3.64
GEG90ES	GEG90ES-2RS	90	150	85	55	130	1	1	607	3030	15	5.22
GEG100ES	GEG100ES-2RS	100	160	85	55	140	1	1	654	3270	14	6.05
GEG110ES	GEG110ES-2RS	110	180	100	70	160	1	1	950	4750	12	9.68
GEG120ES	GEG120ES-2RS	120	210	115	70	180	1	1	1070	5350	16	14.01
GEG140ES	GEG140ES-2RS	140	230	130	80	200	1	1	1360	6800	16	19.01
GEG160ES	GEG160ES-2RS	160	260	135	80	225	1.1	1.1	1530	7650	16	24.70
GEG180ES	GEG180ES-2RS	180	290	155	100	250	1.1	1.1	2120	10600	14	35.90
GEG200ES	GEG200ES-2RS	200	320	165	100	275	1.1	1.1	2320	11600	15	45.28
GEG220ES	GEG220ES-2RS	220	340	175	100	300	1.1	1.1	2550	12700	16	51.12
GEG240ES	GEG240ES-2RS	240	370	190	110	325	1.1	1.1	3030	15190	15	65.12
GEG260ES	GEG260ES-2RS	260	400	205	120	350	1.1	1.1	3570	17850	15	82.44
GEG280ES	GEG280ES-2RS	280	430	210	120	375	1.1	1.1	3800	19100	15	97.21

GEEW..ES

Inner Race: Gcr15 Steel,hardened HRC 58-64,
surface phosphated.

Outer Race: Gcr15 Steel,hardened HRC 54-60,
surface phosphated.

Bore size $d \geq 140\text{mm}$: Inner and outer race are
all Gcr15 SiMn.

Sliding contact surfaces: Steel/Steel.

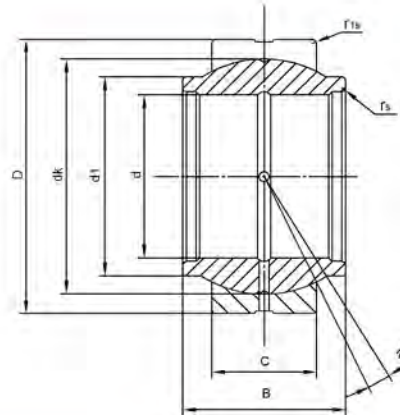

Bearing No.	Dimensions(mm)								Load Ratings KN		a ³ ≈	Weight ≈ kg
	d	D	B	C	d ₁	dk	r _s	r _{1s}	Dynamic	Static		
GEEW12ES*	12	22	12	7	15.5	18	0.3	0.3	10	53	4	0.022
GEEW15ES	15	26	15	9	18.5	22	0.3	0.3	16	84	5	0.031
GEEW16ES	16	28	16	9	20	23	0.3	0.3	17	85	4	0.035
GEEW17ES	17	30	17	10	21	25	0.3	0.3	21	106	7	0.044
GEEW20ES	20	35	20	12	25	29	0.3	0.3	30	146	4	0.071
GEEW25ES	25	42	25	16	30.5	35.5	0.6	0.6	48	240	4	0.131
GEEW30ES	30	47	30	18	34	40.7	0.6	0.6	62	310	4	0.168
GEEW32ES	32	52	32	18	37	43	0.6	1	65	328	4	0.182
GEEW35ES	35	55	35	20	40	47	0.6	1	79	399	4	0.253
GEEW40ES	40	62	40	22	46	53	0.6	1	99	495	4	0.338
GEEW45ES	45	68	45	25	52	60	0.6	1	127	637	4	0.481
GEEW50ES	50	75	50	28	57	66	0.6	1	156	780	4	0.558
GEEW60ES	60	90	60	36	68	80	1	1	245	1220	4	1.15
GEEW63ES	63	95	63	36	71.5	83	1	1	253	1260	4	1.25
GEEW70ES	70	105	70	40	78	92	1	1	313	1560	4	1.71
GEEW80ES	80	120	80	45	91	105	1	1	400	2000	4	2.39
GEEW90ES	90	130	90	50	99	115	1	1	488	2440	4	3.21
GEEW100ES	100	150	100	55	113	130	1	1	607	3030	4	4.79
GEEW110ES	110	160	110	55	124	140	1	1	654	3270	4	5.78
GEEW125ES	125	180	125	70	138	160	1	1	950	4750	4	8.49
GEEW160ES	160	230	160	80	177	200	1	1	1360	6800	4	16.5
GEEW200ES	200	290	200	100	221	250	1.1	1.1	2120	10600	4	32.1
GEEW250ES	250	400	250	120	317	350	1.1	1.1	3750	17800	4	99.1
GEEW320ES	320	520	320	160	405	450	1.1	1.1	6200	30500	4	231

*A lubrication groove and holes in the outer ring only.
Can supply spherical plain bearing with two seals for bore diameter $d \geq \varnothing 15\text{mm}$.

GEEM..ES-2RS

Inner Race: Gcr15 Steel, hardened HRC 58-64, surface phosphated.

Outer Race: Gcr15 Steel, hardened HRC 54-60, surface phosphated.

Sliding contact surfaces: Steel/Steel.

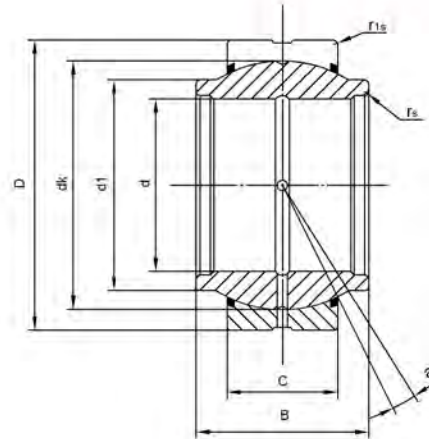

Bearing No.	Dimensions(mm)								Load ratings KN		a°	Weight ≈ kg
	d	D	B	C	d1	dk	rs	r1s	Dynamic	Static		
GEEM20ES-2RS	20	35	24	12	24	29	0.3	0.3	30	146	6	0.073
GEEM25ES-2RS	25	42	29	16	29	35.5	0.3	0.6	48	240	4	0.13
GEEM30ES-2RS	30	47	30	18	34	40.7	0.3	0.6	62	310	4	0.17
GEEM35ES-2RS	35	55	35	20	40	47	0.6	1.0	79	399	4	0.25
GEEM40ES-2RS	40	62	38	22	45	53	0.6	1.0	99	495	4	0.35
GEEM45ES-2RS	45	68	40	25	52	60	0.6	1.0	127	637	4	0.49
GEEM50ES-2RS	50	75	43	28	57	66	0.6	1.0	156	780	4	0.60
GEEM60ES-2RS	60	90	54	36	68	80	0.6	1.0	245	1220	3	1.15
GEEM70ES-2RS	70	105	65	40	78	92	0.6	1.0	313	1560	4	1.65
GEEM80ES-2RS	80	120	74	45	90	105	0.6	1.0	400	2000	4	2.50

GE..C
GEG..C

Ball:Gcr15 Steel,hardened HRC 58-64, Precision ground, hard chrome plated.

Outer Race:Carbon Steel with PTFE composite.

Sliding contact surfaces : Steel/ PTFE composite.

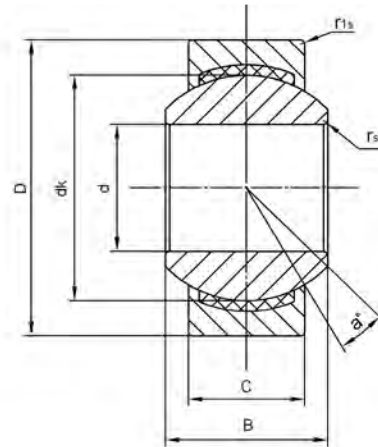

Bearing No.	Dimensions(mm)							Load ratings KN		a° ≈	weight ≈ kg
	d	D	B	C	dk	r _s mm	r _{1s} mm	Dynamic	Static		
GE..C											
GE4C	4	12	5	3	8	0.3	0.3	2.1	5.4	16	0.003
GE5C	5	14	6	4	10	0.3	0.3	3.6	9.1	13	0.005
GE6C	6	14	6	4	10	0.3	0.3	3.6	9.1	13	0.004
GE8C	8	16	8	5	13	0.3	0.3	5.8	14	15	0.008
GE10C	10	19	9	6	16	0.3	0.3	8.6	21	12	0.011
GE12C	12	22	10	7	18	0.3	0.3	11	28	10	0.015
GE15C	15	26	12	9	22	0.3	0.3	18	45	8	0.027
GE17C	17	30	14	10	25	0.3	0.3	22	56	10	0.041
GE20C	20	35	16	12	29	0.3	0.3	31	78	9	0.066
GE25C	25	42	20	16	35.5	0.6	0.6	51	127	7	0.119
GE30C	30	47	22	18	40.7	0.6	0.6	65	166	6	0.163
GEG..C											
GEG4C	4	14	7	4	10	0.3	0.3	3.6	9.1	20	0.005
GEG5C	5	16	9	5	13	0.3	0.3	5.8	14	21	0.008
GEG6C	6	16	9	5	13	0.3	0.3	5.8	14	21	0.006
GEG8C	8	19	11	6	16	0.3	0.3	8.6	21	21	0.014
GEG10C	10	22	12	7	18	0.3	0.3	11	28	18	0.021
GEG12C	12	26	15	9	22	0.3	0.3	18	45	18	0.033
GEG15C	15	30	16	10	25	0.3	0.3	22	56	16	0.049
GEG17C	17	35	20	12	29	0.3	0.3	31	78	19	0.083
GEG20C	20	42	25	16	35.5	0.3	0.3	51	127	17	0.153
GEG25C	25	47	28	18	40.7	0.6	0.6	65	166	17	0.203
GEG30C	30	55	32	20	47	0.6	0.6	83	212	17	0.304

GEBK..S

Ball: Gcr15 Steel,hardened HRC 58-64,
Precision ground,hard chrome plated.

Race: Brass

Outer Race:Carbon steel

Sliding contact surfaces:Steel/Brass.

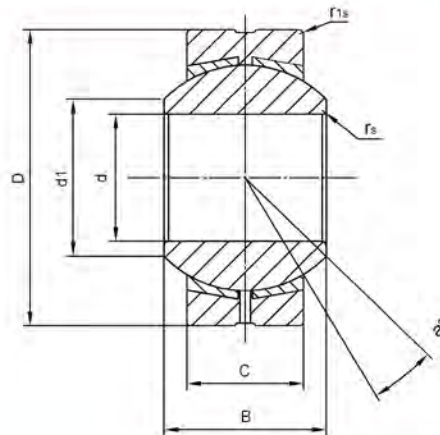

Bearing No.	Dimensions(mm)							Load ratings KN		a ^v ≈	weight ≈ kg
	d	D	B	C	dk	r _s	r _{1s}	Dynamic	Static		
GEBK5S	5	16	8	6	11.112	0.3	0.3	3.3	7.8	13	0.009
GEBK6S	6	18	9	6.75	12.7	0.3	0.3	4.3	9.8	13	0.013
GEBK8S	8	22	12	9	15.88	0.3	0.3	6.8	16	14	0.024
GEBK10S	10	26	14	10.5	19.05	0.3	0.6	10	23	14	0.039
GEBK12S	12	30	16	12	22.23	0.3	0.6	13	31	13	0.058
GEBK14S	14	34	19	13.5	25.4	0.3	0.6	17	40	16	0.084
GEBK16S	16	38	21	15	28.58	0.3	0.6	21	50	15	0.111
GEBK18S	18	42	23	16.5	31.75	0.6	0.6	26	61	15	0.16
GEBK20S	20	46	25	18	34.93	0.6	0.6	31	73	15	0.21
GEBK22S	22	50	28	20	38.1	0.6	0.6	38	88	15	0.26
GEBK25S	25	56	31	22	42.86	0.6	0.6	47	110	15	0.39
GEBK28S	28	62	35	25	47.63	0.6	0.6	59	138	15	0.53
GEBK30S	30	66	37	25	50.8	0.6	0.6	63	148	17	0.61

GE..PW

Ball: Gcr15 Steel,hardened HRC 58-64,
Precision ground, hard chrome plated.

Outer Race: Carbon steel, with liner of PTFE composite.

Sliding contact surfaces: Steel/PTFE.

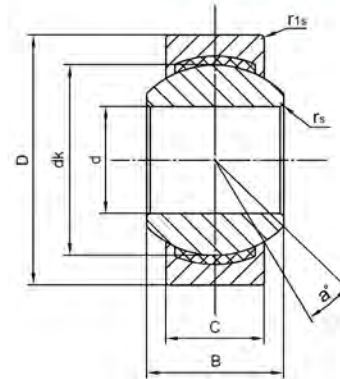

Bearing No.	Dimensions(mm)							Load ratings KN		a°	weight ≈ kg
	d	D	B	C	dk	r _s	r _{1s}	Dynamic	Static		
GE5PW	5	13	8	6	11.112	0.3	0.3	6	15	13	0.006
GE6PW	6	16	9	6.75	12.7	0.3	0.3	7.65	19.3	13	0.010
GE8PW	8	19	12	9	15.875	0.3	0.3	12.9	32	14	0.018
GE10PW	10	22	14	10.5	19.05	0.3	0.3	18	45	13	0.027
GE12PW	12	26	16	12	22.225	0.3	0.3	24	60	13	0.043
GE14PW	14	28	19	13.5	25.4	0.3	0.3	31	76.5	16	0.055
GE16PW	16	32	21	15	28.575	0.3	0.3	39	96.5	15	0.08
GE18PW	18	35	23	16.5	31.75	0.3	0.3	47.5	118	15	0.10
GE20PW	20	40	25	18	34.925	0.3	0.6	57	140	14	0.15
GE22PW	22	42	28	20	38.1	0.3	0.6	68	170	15	0.18
GE25PW	25	47	31	22	42.85	0.3	0.6	85	212	15	0.24
GE30PW	30	55	37	25	50.8	0.3	0.6	114	285	17	0.38

GE..ET-2RS GE..XT-2RS

Inner Race: Gcr15 Steel, hardened HRC 58-64, precision ground, hard chrome plated.

Outer Race: Gcr15 Steel, hardened HRC 54-60, surface phosphated, with liner of PTFE fabric.

Material of outer and inner race for bore size
 $d \geq 140\text{mm}$: Gcr15SiMn

Sliding contact surfaces: Steel/PTFE fabric.

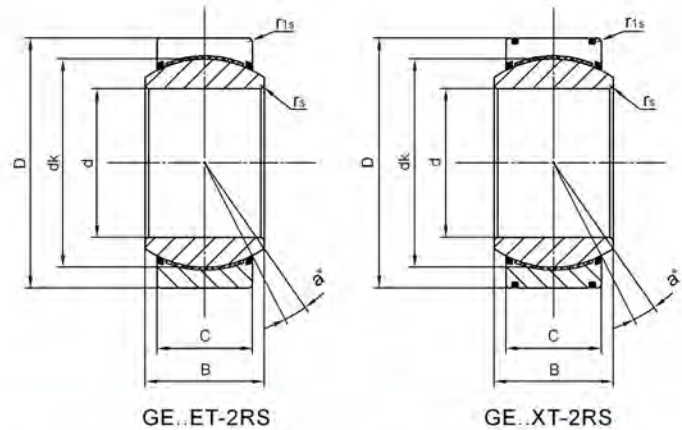

Bearing No.	Dimensions(mm)							Load ratings KN		α° ≈	weight ≈ kg
	d	D	B	C	dk	rs	r1s	Dynamic	Static		
GE15ET-2RS	15	26	12	9	22	0.3	0.3	25	50	8	0.027
GE17ET-2RS	17	30	14	10	25	0.3	0.3	32	64	10	0.041
GE20ET-2RS	20	35	16	12	29	0.3	0.3	45	90	9	0.066
GE25ET-2RS	25	42	20	16	35.5	0.6	0.6	85	170	7	0.119
GE30ET-2RS	30	47	22	18	40.7	0.6	0.6	110	220	6	0.153
GE35ET-2RS	35	55	25	20	47	0.6	1	140	280	6	0.233
GE40ET-2RS	40	62	28	22	53	0.6	1	175	350	7	0.306
GE45ET-2RS	45	68	32	25	60	0.6	1	225	450	7	0.427
GE50ET-2RS	50	75	35	28	66	0.6	1	275	550	6	0.546
GE55ET-2RS	55	85	40	32	74	0.6	1	355	710	7	0.939
GE60ET-2RS	60	90	44	36	80	1	1	430	860	6	1.04
GE70ET-2RS	70	105	49	40	92	1	1	550	1100	6	1.55
GE80ET-2RS	80	120	55	45	105	1	1	705	1410	6	2.31
GE90ET-2RS	90	130	60	50	115	1	1	860	1720	5	2.75
GE100ET-2RS	100	150	70	55	130	1	1	1070	2140	7	4.45
GE110ET-2RS	110	160	70	55	140	1	1	1150	2300	6	4.82
GE120ET-2RS	120	180	85	70	160	1	1	1680	3360	6	8.05
GE140XT-2RS	140	210	90	70	180	1	1	1890	3780	7	11.02
GE160XT-2RS	160	230	105	80	200	1	1	2400	4800	8	14.01
GE180XT-2RS	180	260	105	80	225	1.1	1.1	2700	5400	6	18.65
GE200XT-2RS	200	290	130	100	250	1.1	1.1	3750	7500	7	28.03
GE220XT-2RS	220	320	135	100	275	1.1	1.1	4120	8240	8	35.51
GE240XT-2RS	240	340	140	100	300	1.1	1.1	4500	9000	8	39.91
GE260XT-2RS	260	370	150	110	325	1.1	1.1	5360	10720	7	51.54
GE280XT-2RS	280	400	155	120	350	1.1	1.1	6300	12600	6	65.06
GE300XT-2RS	300	430	165	120	375	1.1	1.1	6750	13500	7	78.07

GEG..ET-2RS
GEG..XT-2RS

Inner Race:Gcr15 Steel, hardened HRC 58-64, precision ground, hard chrome plated.

Outer Race:Gcr15 Steel, hardened HRC 54-60, surface phosphated, with liner of PTFE fabric.

Material of outer and inner race for bore size

$d \geq 140\text{mm}$: Gcr15 SiMn.

Sliding contact surfaces : Steel/ PTFE fabric.

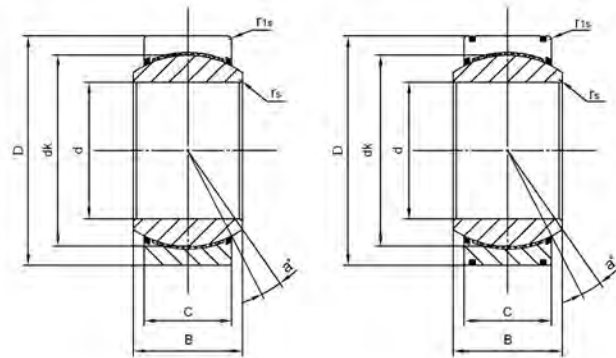

GEG..ET-2RS

GEG..XT-2RS

Bearing No.	Dimensions(mm)							Load ratings KN		a° ≈	weight ≈ kg
	d	D	B	C	dk	rs	r1s	Dynamic	Static		
GEG15ET-2RS	15	30	16	10	25	0.3	0.3	32	64	16	0.049
GEG17ET-2RS	17	35	20	12	29	0.3	0.3	45	90	19	0.083
GEG20ET-2RS	20	42	25	16	35.5	0.3	0.6	85	170	17	0.153
GEG25ET-2RS	25	47	28	18	40.7	0.6	0.6	110	220	17	0.203
GEG30ET-2RS	30	55	32	20	47	0.6	1	140	280	17	0.304
GEG35ET-2RS	35	62	35	22	53	0.6	1	175	350	16	0.408
GEG40ET-2RS	40	68	40	25	60	0.6	1	225	450	17	0.542
GEG45ET-2RS	45	75	43	28	66	0.6	1	275	550	15	0.713
GEG50ET-2RS	50	90	56	36	80	0.6	1	430	860	17	1.14
GEG60ET-2RS	60	105	63	40	92	1	1	550	1100	17	2.05
GEG70ET-2RS	70	120	70	45	105	1	1	705	1410	16	3.01
GEG80ET-2RS	80	130	75	50	115	1	1	860	1720	14	3.64
GEG90ET-2RS	90	150	85	55	130	1	1	1070	2140	15	5.22
GEG100ET-2RS	100	160	85	55	140	1	1	1150	2300	14	6.05
GEG110ET-2RS	110	180	100	70	160	1	1	1680	3360	12	9.68
GEG120XT-2RS	120	210	115	70	180	1	1	1890	3780	16	14.01
GEG140XT-2RS	140	230	130	80	200	1	1	2400	4800	16	19.01
GEG160XT-2RS	160	260	135	80	225	1.1	1.1	2700	5400	16	24.70
GEG180XT-2RS	180	290	155	100	250	1.1	1.1	3750	7500	14	35.90
GEG200XT-2RS	200	320	165	100	275	1.1	1.1	4120	8240	15	45.28
GEG220XT-2RS	220	340	175	100	300	1.1	1.1	4500	9000	16	51.12
GEG240XT-2RS	240	370	190	110	325	1.1	1.1	5360	10720	15	65.12
GEG260XT-2RS	260	400	205	120	350	1.1	1.1	6300	12600	15	82.44
GEG280XT-2RS	280	430	210	120	375	1.1	1.1	6750	13500	15	97.21

GAC..S

Inner Race: Gcr15 Steel, hardened HRC 58-64,
surface phosphated.

Outer Race: Gcr15 Steel, hardened HRC 58-64,
surface phosphated.

Sliding contact surfaces : Steel/ Steel

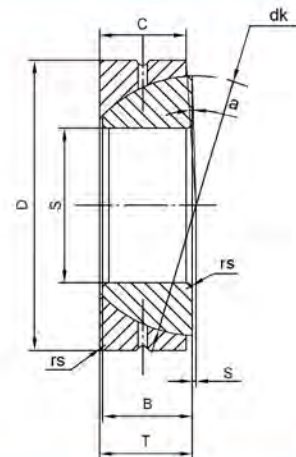

Bearing No.	Dimensions(mm)								Load ratings KN		a° ≈	Weight ≈ kg
	d	D	B	C	T	dk	S	r _s mm	Dynamic	Static		
GAC25S	25	47	15	14	15	42	0,6	1	50	250	2,5	0,148
GAC28S	28	52	15	15	16	47	1	1	60	300	2	0,186
GAC30S	30	55	17	15	17	49,5	1,3	1	63	315	4,5	0,208
GAC32S	32	58	17	16	17	52	2	1	71	354	2	0,241
GAC35S	35	62	18	16	18	55,5	2,1	1	78	390	4	0,268
GAC40S	40	68	19	17	19	62	2,8	1	92	463	5	0,327
GAC45S	45	75	20	18	20	68,5	3,5	1	108	540	3	0,416
GAC50S	50	80	20	19	20	74	4,3	1	123	618	1,5	0,455
GAC55S	55	90	23	20	23	82	5	1,1	144	721	4	0,645
GAC60S	60	95	23	21	23	88,5	5,7	1,1	163	817	2,5	0,714
GAC65S	65	100	23	22	23	93,5	6,5	1,1	180	905	1	0,759
GAC70S	70	110	25	23	25	102	7,2	1,1	206	1030	2	1,04
GAC75S	75	115	25	24	25	107	7,9	1,1	220	1129	1	1,12
GAC80S	80	125	29	25,5	29	115	8,6	1,1	258	1290	3,5	1,54
GAC85S	85	130	29	26,5	29	122	9,4	1,1	284	1422	2	1,61
GAC90S	90	140	32	28	32	128,5	10,1	1,5	316	1580	3,5	2,09
GAC95S	95	145	32	29,5	32	135	10,8	1,5	350	1750	2	2,22
GAC100S	100	150	32	31	32	141	11,6	1,5	384	1923	0,5	2,34
GAC105S	105	160	35	32,5	35	148	12,3	2	423	2116	2	2,93
GAC110S	110	170	38	34	38	155	13	2	463	2318	3	3,68
GAC120S	120	180	38	37	38	168	14,5	2	547	2735	0,5	3,97
GAC130S	130	200	45	43	45	188	18	2,5	710	3550	1	5,92
GAC140S	140	210	45	43	45	198	19	2,5	740	3740	1	6,33
GAC150S	150	225	48	46	48	211	20	3	850	4270	1	8,01
GAC160S	160	240	51	49	51	225	20	3	970	4850	1	9,42
GAC170S	170	260	57	55	57	246	21	3	1190	5950	1	12,3
GAC180S	180	280	64	61	64	260	21	3	1395	6970	1	17,4
GAC190S	190	290	64	62	64	275	26	3	1500	7500	0,5	18,2
GAC200S	200	310	70	66	70	290	26	3	1680	8420	1,5	22,5

GAC..T

Outer Race: Gcr15 Steel, hardened HRC 58-64,
surface phosphated and with liner
of PTFE fabric.

Inner Race: Gcr15 Steel, hardened HRC 58-64,
precision ground, hard chrome plated.

Sliding contact surfaces : Steel/PTFE fabric

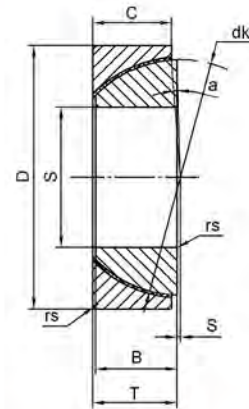

Bearing No.	Dimensions(mm)								Load ratings KN		a ^e ≈	Weight ≈ kg
	d	D	B	C	T	dk	S	r _s	Dynamic	Static		
GAC25T	25	47	15	14	15	42	0.6	1	75	149	3.5	0.148
GAC28T	28	52	15	15	16	47	1	1	100	200	2	0.186
GAC30T	30	55	17	15	17	49.5	1.3	1	95	188	3	0.208
GAC32T	32	58	17	16	17	52	2	1	125	250	2	0.241
GAC35T	35	62	18	16	18	55.5	2.1	1	117	234	3	0.268
GAC40T	40	68	19	17	19	62	2.8	1	139	277	3	0.327
GAC45T	45	75	20	18	20	68.5	3.5	1	162	324	3	0.416
GAC50T	50	80	20	19	20	74	4.3	1	185	370	3	0.455
GAC55T	55	90	23	20	23	82	5	1.1	216	432	3	0.645
GAC60T	60	95	23	21	23	88.5	5.7	1.1	245	489	3	0.714
GAC65T	65	100	23	22	23	93.5	6.5	1.1	271	542	2.5	0.759
GAC70T	70	110	25	23	25	102	7.2	1.1	309	618	2.5	1.04
GAC75T	75	115	25	24	25	107	7.9	1.1	339	676	2.5	1.12
GAC80T	80	125	29	25.5	29	115	8.6	1.1	387	772	2.5	1.54
GAC85T	85	130	29	26.5	29	122	9.4	1.1	426	851	2.5	1.61
GAC90T	90	140	32	28	32	128.5	10.1	1.5	474	948	2.5	2.09
GAC95T	95	145	32	29.5	32	135	10.8	1.5	525	1049	2.5	2.22
GAC100T	100	150	32	31	32	141	11.6	1.5	577	1151	2	2.34
GAC105T	105	160	35	32.5	35	148	12.3	2	634	1267	2	2.93
GAC110T	110	170	38	34	38	155	13	2	695	1380	2	3.68
GAC120T	120	180	38	37	38	168	14.5	2	820	1630	2	3.97
GAC130T	130	200	45	43	45	188	18	2.5	1060	2130	1	5.92
GAC140T	140	210	45	43	45	198	19	2.5	1120	2240	1	6.33
GAC150T	150	225	48	46	48	211	20	3	1280	2550	1	8.01
GAC160T	160	240	51	49	51	225	20	3	1445	2900	1	9.42
GAC170T	170	260	57	55	57	246	21	3	1780	3560	1	12.3
GAC180T	180	280	64	61	64	260	21	3	2090	4170	1	17.4
GAC190T	190	290	64	62	64	275	26	3	2250	4490	1.5	18.2
GAC200T	200	310	70	66	70	290	26	3	2520	5040	1	22.5

GACZ..S

Outer Race: Gcr15 Steel, hardened HRC 58-64, precision ground, surface phosphated.

Inner Race: Gcr15 Steel, hardened HRC 58-64, precision ground, surface phosphated.

Slidingcontact surfaces : Steel/ Steel

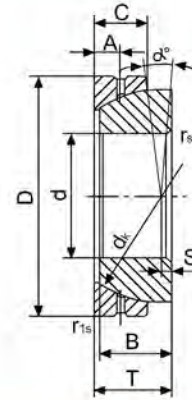

Bearing No.	Dimensions(mm/inch)										Load ratings KN		weight ≈ kg
	d	D	B	C	T	dk	S	A	r _s , r _{1s} mm	α°	Dynamic	Static	
GACZ12S	12.7	22.225	6.86	4.83	7.62	18.26	1.3	2.39	0.51	7	6	18	0.013
	0.5	0.875	0.27	0.19	0.3	0.719	0.051	0.094	0.02				
GACZ15S	15.875	26.988	8.64	6.35	9.40	22.83	1.48	2.77	0.76	6	10	31	0.025
	0.625	1.0625	0.34	0.25	0.37	0.899	0.058	0.109	0.03				
GACZ19S	19.05	31.75	10.41	7.87	11.18	27.43	1.79	3.18	1	6	16	47	0.038
	0.75	1.25	0.41	0.31	0.44	1.08	0.07	0.125	0.04				
GACZ22S	22.225	36.512	12.19	9.65	13.21	31.95	2.02	4.37	2	5.5	22	66	0.049
	0.875	1.4375	0.48	0.38	0.52	1.258	0.08	0.172	0.08				
GACZ25S	25.4	41.275	13.97	11.18	15.24	36.50	2.54	5.16	2	6	29	87	0.085
	1	1.625	0.55	0.44	0.6	1.437	0.1	0.203	0.08				
GACZ31S	31.75	50.8	17.78	13.97	18.80	45.59	3.36	5.94	2	6	47	142	0.159
	1.25	2	0.7	0.55	0.74	1.795	0.132	0.234	0.08				
GACZ34S	34.925	55.562	19.56	15.24	21.34	49.20	3.69	7.14	2.54	4	53	159	0.213
	1.375	2.1875	0.77	0.6	0.84	1.937	0.145	0.281	0.1				
GACZ38S	38.1	61.912	21.34	16.76	23.11	54.74	3.93	7.92	2.54	5.5	66	197	0.301
	1.5	2.4375	0.84	0.66	0.91	2.155	0.155	0.312	0.1				
GACZ44S	44.45	71.438	24.89	20.07	27.18	63.88	4.72	8.33	2.54	6	91	273	0.458
	1.75	2.8125	0.98	0.79	1.07	2.515	0.186	0.328	0.1				
GACZ50S	50.8	80.962	28.70	23.37	31.24	73.02	5.51	9.52	3.56	5.5	122	365	0.671
	2	3.1875	1.13	0.92	1.23	2.875	0.217	0.375	0.14				
GACZ57S	57.15	90.488	32.26	26.67	35.31	82.17	6.18	11.51	3.56	5.5	155	466	0.948
	2.25	3.5625	1.27	1.05	1.39	3.235	0.243	0.453	0.14				
GACZ63S	63.5	100.013	36.07	29.97	39.12	91.19	6.79	12.7	3.56	5	196	589	1.13
	2.5	3.9375	1.42	1.18	1.54	3.59	0.267	0.5	0.14				
GACZ69S	69.85	111.125	39.62	32.38	43.18	100.33	7.46	13.08	4.6	5	231	694	1.75
	2.75	4.375	1.56	1.275	1.7	3.95	0.294	0.515	0.18				
GACZ76S	76.2	120.65	43.43	35.69	47.24	109.52	8.17	14.68	4.6	5	279	838	2.28
	3	4.75	1.71	1.405	1.86	4.312	0.322	0.578	0.18				
GACZ82S	82.55	130.175	47.24	39.24	51.56	118.74	9.04	16.66	4.6	5	332	995	2.89
	3.25	5.125	1.86	1.545	2.03	4.675	0.356	0.656	0.18				

GACZ..S

Outer Race: Gcr15 Steel, hardened HRC 58-64, precision ground, surface phosphated.

Inner Race: Gcr15 Steel, hardened HRC 58-64, precision ground, surface phosphated.

Slidingcontact surfaces : Steel/ Steel

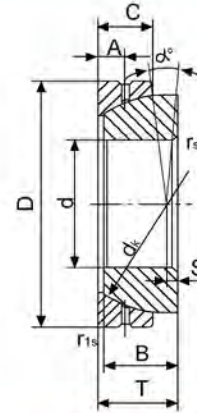

Bearing No.	Dimensions(mm/inch)										Load ratings KN		weight ≈ kg
	d	D	B	C	T	d _k	S	A	r _s , r _{1s} mm	α°	Dynamic	Static	
GACZ88S	88.9	139.7	50.80	42.54	55.37	128.02	9.51	17.86	4.6	5	389	1167	3.57
	3.5	5.5	2	1.675	2.18	5.04	0.374	0.703	0.18				
GACZ95S	95.25	149.225	54.61	45.85	59.44	136.91	10.1	19.43	4.6	4.5	449	1348	4.35
	3.75	5.875	2.15	1.805	2.34	5.39	0.398	0.765	0.18				
GACZ101S	101.6	158.75	58.42	49.15	63.50	146.05	10.4	19.84	4.6	4.5	515	1545	5.26
	4	6.25	2.3	1.935	2.5	5.75	0.409	0.781	0.18				
GACZ114S	114.3	177.8	65.79	55.75	71.12	164.46	12.4	22.22	4.6	4.5	663	1990	7.76
	4.5	7	2.59	2.195	2.8	6.475	0.488	0.875	0.18				
GACZ127S	127	196.85	73.15	62.36	79.50	182.63	13.9	25.4	4.6	4.5	818	2445	11.07
	5	7.75	2.88	2.455	3.13	7.19	0.547	1	0.18				
GACZ152S	152.4	222.25	78.74	66.42	85.72	207.16	16.1	34.8	4.6	4.5	985	2955	17.37
	6	8.75	3.1	2.615	3.375	8.156	0.634	1.37	0.18				

GX..S

Inner Race: Gcr15 Steel, hardened HRC 58-64, surface phosphated.

Outer Race: Gcr15 Steel, hardened HRC 58-64, precision ground, has lubrication groove and hole.

Sliding contact surfaces : Steel/ Steel

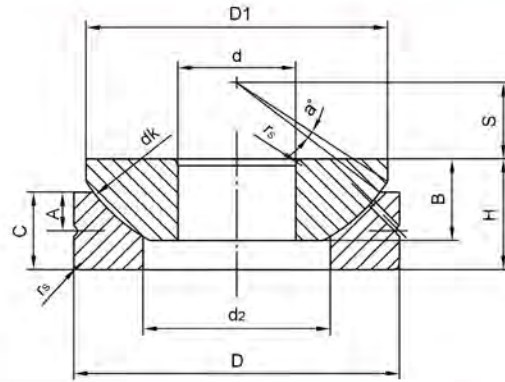

Bearing No.	Dimensions(mm)											Ratings load KN		a°	Weight ≈ kg
	d	D	H	B	C	dk	d ₂ _{min}	D ₁ _{max}	A	S	r _s	Dynamic	Static		
GX10S	10	30	9.5	7.5	7	32	15.5	27.5	3	7	0.6	27	136	9	0.036
GX12S	12	35	13	9.5	9.3	38	18	32	4	8	0.6	37	188	8	0.072
GX15S	15	42	15	11	10.8	46	22.5	39	5	10	0.6	53	267	8	0.108
GX17S	17	47	16	11.8	11.2	52	27	43.5	5	11	0.6	61	311	10	0.137
GX20S	20	55	20	14.5	13.8	60	31	50	6	12.5	1.0	84	425	9	0.246
GX25S	25	62	22.5	16.5	16.7	68	34.5	58.5	6	14	1.0	134	672	7	0.415
GX30S	30	75	26	19	19	82	42	70	8	17.5	1.0	182	909	7	0.614
GX35S	35	90	28	22	20.7	98	50.5	84	8	22	1.0	266	1330	8	0.973
GX40S	40	105	32	27	21.5	114	59	97	9	24.5	1.0	357	1810	9	1.59
GX45S	45	120	36.5	31	25.5	128	67	110	11	27.5	1.0	486	2470	9	2.24
GX50S	50	130	42.5	33	30.5	139	70	120	10	30	1.0	554	2810	7	3.14
GX60S	60	150	45	37	34	160	84	140	12.5	35	1.0	748	3820	8	4.63
GX70S	70	160	50	42	36.5	176	94.5	153	13.5	35	1.0	902	4610	8	5.37
GX80S	80	180	50	43.5	38	197	107.5	172	14.5	42.5	1.0	1110	5700	8	6.91
GX100S	100	210	59	51	46	222	127	198	15	45	1.1	1300	6470	8	10.9
GX120S	120	230	64	53.5	50	250	145	220	16.5	52.5	1.1	1530	7580	6	13.9
GX140S	140	260	72	61	54	274	177	243	23	52.5	1.5	1820	9040	6	18.1
GX160S	160	290	77	66	58	313	200	271	23	65	1.5	2100	10440	7	23.2
GX180S	180	320	86	74	62	340	225	299	26	67.5	1.5	2430	12070	8	30.9
GX200S	200	340	87	80	66	365	247	320	27	70	1.5	3070	15280	8	34.2

GX..T

Outer Race: Gcr15 Steel, hardened HRC 58-64,
surface phosphated and with liner
of PTFE fabric.

Inner Race: Gcr15 Steel, hardened HRC 58-64,
precision ground, hard chrome plated.

Sliding contact surfaces : Steel/ PTFE fabric

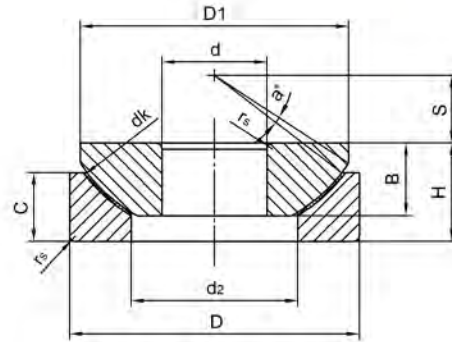

Bearing No.	Dimensions(mm)										Load ratings KN		a° ≈	Weight ≈ kg
	d	D	H	B	C	d ₁	d ₂ min	D ₁ max	S	r _s	Dynamic	Static		
GX10T	10	30	9.5	7.5	7	32	15.5	27.5	7	0.6	40	81	9	0.036
GX12T	12	35	13	9.5	9.3	38	18	32	8	0.6	56	112	8	0.072
GX15T	15	42	15	11	10.8	46	22.5	39	10	0.6	79	160	8	0.108
GX17T	17	47	16	11.8	11.2	52	27	43.5	11	0.6	92	186	10	0.137
GX20T	20	55	20	14.5	13.8	60	31	50	12.5	1	127	255	9	0.246
GX25T	25	62	22.5	16.5	16.7	68	34.5	58.5	14	1	203	407	7	0.415
GX30T	30	75	26	19	19	82	42	70	17.5	1	275	551	7	0.614
GX35T	35	90	28	22	20.7	98	50.5	84	22	1	403	806	9	0.973
GX40T	40	105	32	27	21.5	114	59	97	24.5	1	540	1080	9	1.59
GX45T	45	120	36.5	31	25.5	128	67	110	27.5	1	730	1470	7	2.24
GX50T	50	130	42.5	33	30.5	139	70	120	30	1	840	1670	8	3.14
GX60T	60	150	45	37	34	160	84	140	35	1	1140	2280	8	4.63
GX70T	70	160	50	42	36.5	176	94.5	153	35	1	1370	2750	8	5.37
GX80T	80	180	50	43.5	38	197	107.5	172	42.5	1	1700	3410	8	6.91
GX100T	100	210	59	51	46	222	127	198	45	1.1	1940	3890	8	10.9
GX120T	120	230	64	53.5	50	250	145	220	52.5	1.1	2170	4560	6	13.9
GX140T	140	260	72	61	54	274	177	243	52.5	1.5	2700	5440	6	18.1
GX160T	160	290	77	66	58	313	200	271	65	1.5	3265	6250	7	23.2
GX180T	180	320	86	74	62	340	225	299	67.5	1.5	3700	7220	8	30.9
GX200T	200	340	87	80	66	365	247	320	70	1.5	4780	9150	8	34.2

COM/HCOM & COM-T/HCOM-T

Ball: Gcr15 Steel, hardened HRC 58-64,

precision ground, hard chrome plated.

Outer Race: Carbon steel.

COM..T/HCOMT.. : PTFE composite or PTFE fabric

Sliding contact surfaces: steel/steel or steel/PTFE composite.

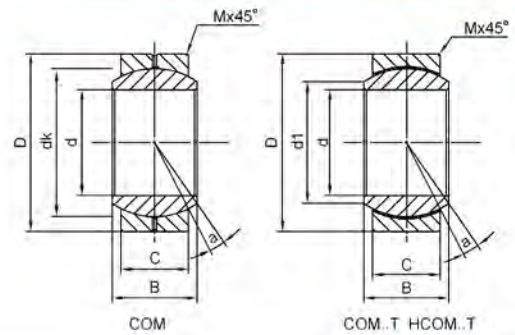

Bearing No.	Dimensions(mm)						Misalign angle a°	Ult. Radial static load (KN)	Weight ≈ kg
	d ^{+0.038 -0.012}	D ^{+0 -0.018}	B _{±0.127}	C _{±0.127}	dk	r _{sx45°}			
COM3	0.1900	0.5625	0.281	0.281	0.406	0.020	11	21.6	0.0045
COM3T	4.825	14.288	7.14	5.54	10.31	0.4			
COM4	0.2500	0.6562	0.343	0.250	0.500	0.022	13.5	33	0.009
COM4T	6.35	16.667	8.71	6.35	12.7	0.55			
COM5	0.3125	0.7500	0.375	0.281	0.562	0.032	12	43.2	0.0136
COM5T	7.938	19.05	9.53	7.14	14.27	0.8			
COM6	0.3750	0.8125	0.406	0.312	0.656	0.032	10	56	0.018
COM6T	9.525	20.638	10.31	7.92	16.66	0.8			
COM7	0.4375	0.9062	0.437	0.434	0.718	0.032	8	63	0.022
COM7T	11.113	23.017	11.1	8.71	18.23	0.8			
COM8	0.5000	1.0000	0.500	0.390	0.813	0.032	9.5	88.4	0.031
COM8T	12.7	25.4	12.7	9.91	20.65	0.8			
COM9	0.5625	1.0937	0.562	0.437	0.906	0.032	9.5	110.9	0.040
COM9T	14.288	27.78	14.28	11.1	23.01	0.8			
COM10	0.6250	1.1875	0.625	0.500	1.000	0.032	8.5	141.9	0.049
COM10T	15.875	30.163	15.88	12.7	25.4	0.8			
COM12	0.7500	1.4375	0.750	0.593	1.187	0.044	9	212.98	0.090
COM12T	19.05	36.512	19.05	15.06	30.15	1.1			
COM14	0.8750	1.5625	0.875	0.703	1.312	0.044	9.5	279.9	0.118
COM14T	22.225	39.688	22.23	17.86	33.32	1.1			
COM16	1.0000	1.7500	1.00	0.797	1.500	0.044	10	368.3	0.177
COM16T	25.4	44.45	25.4	20.24	38.1	1.1			
HCOM../HCOM..T									
HCOM16	1.0000	2.0000	1.000	0.781	1.678	0.032	9	472.5	0.249
HCOM16T	25.4	50.8	25.4	19.84	42.62	0.8			
HCOM19	1.1875	2.3750	1.187	0.937	2.000	0.032	8.5	672.1	0.408
HCOM19T	30.162	60.325	30.15	23.8	50.8	0.8			
HCOM20	1.2500	2.3750	1.175	0.937	2.000	0.032	8.5	672.1	0.408
HCOM20T	31.75	60.325	30.15	23.8	50.8	0.8			
HCOM24	1.5000	2.7500	1.375	1.094	2.312	0.032	8.5	907.1	0.616
HCOM24T	38.1	69.85	34.92	27.79	58.72	0.8			
HCOM28	1.7500	3.1250	1.562	1.250	2.625	0.044	8.0	1176.7	0.884
HCOM28T	44.45	79.375	39.67	31.75	66.68	1.1			
HCOM32	2.0000	3.5000	1.750	1.375	2.937	0.044	8.5	1448.2	1.206
HCOM32T	50.8	88.9	44.45	34.92	74.6	1.1			

SCOM & SCOM..T

BALL

- 440C Stainless steel
- Heat treated
- Hard chrome plated
- Precision ground

RACE

- 300 Series stainless steel
- PTFE lined (COM-SST)

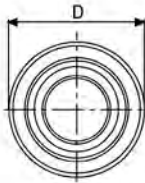

SCOM

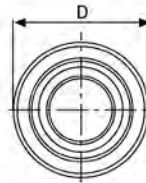
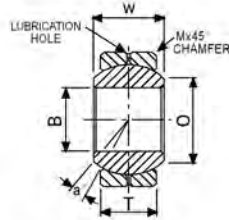

SCOM..T

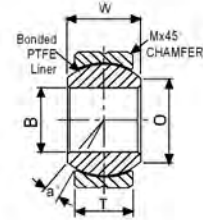

Bearing No.		DIMENSIONS IN INCHES								
Metal to Metal	B + .0015 - .0005	D + .0000 - .0007	T ± .005	W ± .005	O Shoulder Dia. Ref.	M Chamfer Ref.	Ball Dia. Ref.	Misalign. Angle a°	Ult. Raidal Static Load Lbs.	Approx. Brg. Wt. Lbs.
SCOM2	0.1650	0.4687	0.187	0.250	0.235	0.020	0.343	9.0	3,200	0.01
SCOM3	0.1900	0.5625	0.218	0.281	0.293	0.020	0.406	11.0	4,400	0.01
SCOM4	0.2500	0.6562	0.250	0.343	0.364	0.022	0.500	13.5	6,700	0.02
SCOM5	0.3125	0.7500	0.281	0.375	0.419	0.032	0.562	12.0	9,200	0.03
SCOM6	0.3750	0.8125	0.312	0.406	0.516	0.032	0.656	10.0	12,400	0.04
SCOM7	0.4375	0.9062	0.343	0.437	0.530	0.032	0.718	8.0	14,900	0.05
SCOM8	0.5000	1.0000	0.390	0.500	0.640	0.032	0.813	9.5	17,900	0.07
SCOM9	0.5625	1.0937	0.437	0.562	0.710	0.032	0.906	9.5	23,700	0.09
SCOM10	0.6250	1.1875	0.500	0.625	0.780	0.032	1.000	8.5	32,000	0.11
SCOM12	0.7500	1.4375	0.593	0.750	0.920	0.044	1.187	9.0	48,000	0.20
SCOM14	0.8750	1.5625	0.703	0.875	0.980	0.044	1.312	9.5	69,000	0.26
SCOM16	1.0000	1.7500	0.797	1.000	1.118	0.044	1.500	10.0	83,000	0.39

Bearing No.		DIMENSIONS IN INCHES								
PIFE Lined	B + .0015 - .0005	D + .0000 - .0007	T ± .005	W ± .005	O Shoulder Dia. Ref.	M Chamfer Ref.	Ball Dia. Ref.	Misalign. Angle a°	Ult. Raidal Static Load Lbs.	Approx. Brg. Wt. Lbs.
SCOM3T	0.1900	0.5625	0.218	0.281	0.293	0.020	0.406	11.0	4,400	0.01
SCOM4T	0.2500	0.6562	0.250	0.343	0.364	0.022	0.500	13.5	6,700	0.02
SCOM5T	0.3125	0.7500	0.281	0.375	0.419	0.032	0.562	12.0	9,200	0.03
SCOM6T	0.3750	0.8125	0.312	0.406	0.516	0.032	0.656	10.0	12,400	0.04
SCOM7T	0.4375	0.9062	0.343	0.437	0.530	0.032	0.718	8.0	14,900	0.05
SCOM8T	0.5000	1.0000	0.390	0.500	0.640	0.032	0.813	9.5	17,900	0.07
SCOM9T	0.5625	1.0937	0.437	0.562	0.710	0.032	0.906	9.5	23,700	0.09
SCOM10T	0.6250	1.1875	0.500	0.625	0.780	0.032	1.000	8.5	32,000	0.11
SCOM12T	0.7500	1.4375	0.593	0.750	0.920	0.044	1.187	9.0	48,000	0.20
SCOM14T	0.8750	1.5625	0.703	0.875	0.980	0.044	1.312	9.5	69,000	0.26
SCOM16T	1.0000	1.7500	0.797	1.000	1.118	0.044	1.500	10.0	83,000	0.39

WSSB & WSSB..V

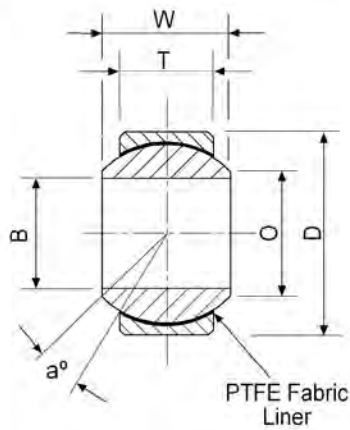

• WSSB

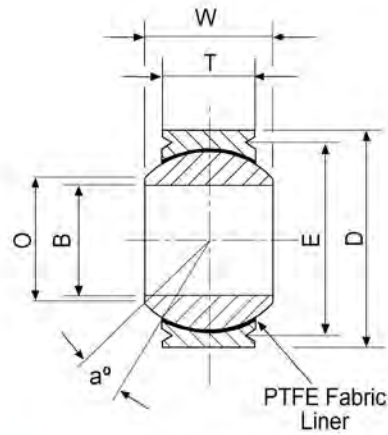

• WSSB-V

Bearing No.		B	D	W	T	E	O	a°	Static Radial Limit Load (Pounds)	Static Axial Limit Load (Pounds)	Dynamic Oscillating Radial Load (Pounds)	Approx. Weight (Pounds)	
		+ .0000 - .0005	+ .0000 - .0005	+ .000 - .002	$\pm .005$	+ .000 - .010	REF						REF
		Ball Bore	Outside Diameter	Ball Width	Race Width	"V" Groove Diameter	Ball Flat Diameter	Ball Diameter	Misalign Angle				
WSSB3	WSSB3V	.1900	.6250	.437	.327	.565	.301	.531	15	9,000	1,770	3,770	.031
WSSB4	WSSB4V	.2500	.6250	.437	.327	.565	.301	.531	15	9,000	1,770	3,770	.031
WSSB5	WSSB5V	.3125	.6875	.437	.317	.627	.401	.593	14	9,400	1,640	4,650	.035
WSSB6	WSSB6V	.3750	.8125	.500	.406	.714	.471	.687	8	13,700	2,630	6,390	.060
WSSB7	WSSB7V	.4375	.9375	.562	.442	.839	.542	.781	10	20,700	3,650	9,390	.080
WSSB8	WSSB8V	.5000	1.0000	.625	.505	.902	.612	.875	9	27,500	4,970	12,150	.100
WSSB10	WSSB10V	.6250	1.1875	.750	.567	1.089	.752	1.062	12	39,000	6,130	16,700	.160
WSSB12	WSSB12V	.7500	1.3750	.875	.630	1.253	.892	1.250	13	52,300	7,730	22,100	.240
WSSB14	WSSB14V	.8750	1.6250	.875	.755	1.503	1.061	1.375	6	67,300	10,800	28,200	.350
WSSB16	WSSB16V	1.0000	2.1250	1.375	1.005	2.003	1.275	1.875	12	137,000	19,300	53,700	.970

Ball
440c Stainless Steel
Rc 56 Min.

Race
17-4 PH
Stainless Steel
Heat Treated

Liner
PTFE Fabric
Permanently Bonded
to Race I.D.

This series is also available with an optional 52100 heat treated and hard chrome plated ball. To specify this configuration use p/n WSBT(3-16) or WSBT(3-16)V in place of part numbers in table.

NSSB & NSSB..V

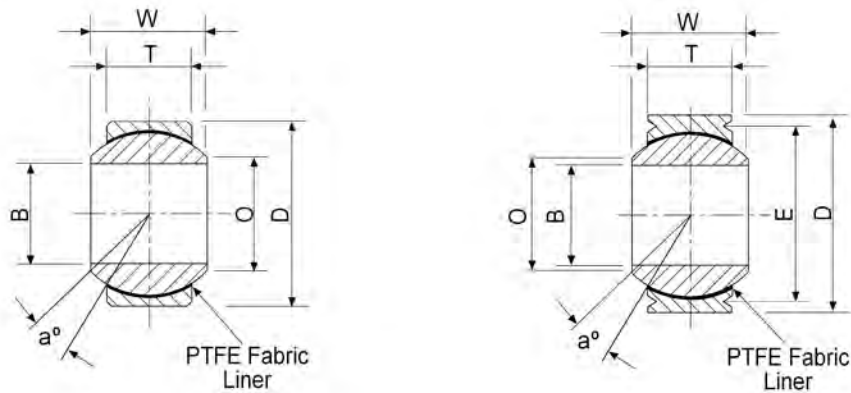

Bearing No.		B	D	W	T	E	O	a°	Static Radial Limit Load (Pounds)	Static Axial Limit Load	Dynamic Oscillating Radial Load (Pounds)	Approx. Weight (Pounds)	
		+0.0000 -0.0005	+0.0000 -0.0005	+0.000 -0.005	±.005	+0.000 -0.010	REF						REF
		Ball Bore	Outside Diameter	Ball Width	Race Width	"V" Groove Diameter	Ball Flat Diameter	Ball Diameter	Misalign Angle				
NSSB3	NSSB3V	.1900	.5625	.281	.218	.502	.293	.406	10	3,975	150	1,500	.020
NSSB4	NSSB4V	.2500	.6562	.343	.250	.596	.364	.500	10	6,040	430	2,320	.020
NSSB5	NSSB5V	.3125	.7500	.375	.281	.652	.419	.562	10	8,750	700	3,430	.030
NSSB6	NSSB6V	.3750	.8125	.406	.312	.714	.515	.656	9	10,540	1,100	4,200	.040
NSSB7	NSSB7V	.4375	.9062	.437	.343	.808	.570	.718	8	13,200	1,400	5,700	.050
NSSB8	NSSB8V	.5000	1.0000	.500	.390	.878	.641	.813	8	17,900	2,100	7,900	.070
NSSB10	NSSB10V	.6250	1.1875	.625	.500	1.065	.739	.968	8	30,500	4,720	13,400	.120
NSSB12	NSSB12V	.7500	1.4375	.750	.593	1.315	.920	1.187	8	46,400	6,750	19,700	.210
NSSB14	NSSB14V	.8750	1.5625	.875	.703	1.440	.978	1.312	8	62,200	9,350	26,100	.270
NSSB16	NSSB16V	1.0000	1.7500	1.000	.797	1.628	1.118	1.500	9	82,200	12,160	34,100	.390

Ball	Race	Liner
440c	17-4PH	Teflon Fabric
Stainless Steel	Stainless Steel	Permanently Bonded
Rc 56 Min.	Heat Treated	to Race I.D.

This series is also available with an optional 52100 heat treated and hard chrome plated ball. To specify this configuration use p/n NSBT(3-16) or NSBT(3-16)V in place of part numbers in table.

YSSB & YSSB..V

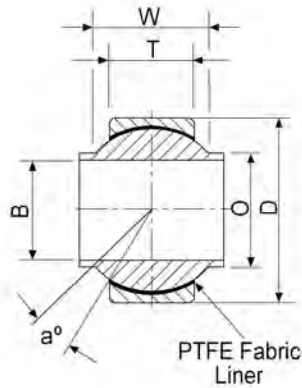

• YSSB

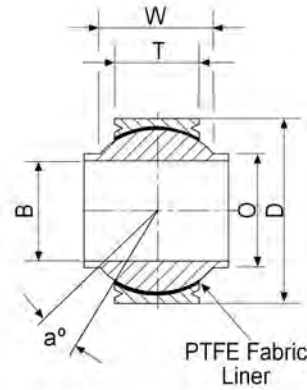

• YSSB-V

Bearing No.		B	D	W	T	O	REF	a°	Static Radial Limit Load (Pounds)	Static Axial Limit Load (Pounds)	Dynamic Oscillating Radial Load (Pounds)	Approx. Weight (Pounds)
		+ .0000 - .0005	+ .0000 - .0005	+ .000 - .002	± .005	+ .000 - .010						
		Ball Bore	Outside Diameter	Ball Width	Race Width	Shoulder Diameter	Ball Diameter	Misalign Angle				
YSSB4	YSSB4V	.2500	.7400	.593	.255	.390	.593	24	7,100	450	3,800	.036
YSSB5	YSSB5V	.3125	.6875	.625	.255	.418	.593	20	9,000	450	3,800	.025
YSSB6	YSSB6V	.3750	.9060	.813	.345	.512	.781	23	16,000	2,000	7,200	.068
YSSB7	YSSB7V	.4375	1.0000	.875	.345	.618	.875	22	19,300	2,000	8,100	.095
YSSB8	YSSB8V	.5000	1.1250	.937	.401	.730	1.000	20	26,100	3,200	10,900	.159
YSSB10	YSSB10V	.6250	1.3750	1.200	.567	.856	1.250	20	44,500	7,000	20,000	.245
YSSB12	YSSB12V	.7500	1.5625	1.280	.620	.970	1.375	18	54,800	8,700	24,200	.315

Ball	Race	Liner
440c	17-4	PTFE Fabric
Stainless Steel	Stainless Steel	Permanently Bonded
Rc 56 Min.	Heat Treated	to Race I.D.

This series is also available with an optional 52100 heat treated and hard chrome plated ball. To specify this configuration use p/n YSBT(4-12) or YSBT(4-12)V in place of part numbers in table.

MIB/MIB..T & AIB/AIB..T & SIB/SIB..T

BALL

- 52100 Bearing Steel
- Heat Treated
- Hard Chrome Plated
- Precision Ground

RACE

MIB: Low Carbon Steel, I.D. Protective Coated for Corrosion Resistance, Oil coated Mfr. Option - Stainless Steel, Heat Treated.

AIB: Alloy Steel, Heat Treated, I.D. Protective Coated for Corrosion Resistance, Oil coated Mfr. Option - Stainless Steel, Heat Treated.

SIB: Stainless Steel, Heat Treated and Oil Coated.

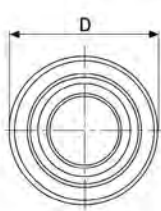

• MIB/AIB/SIB

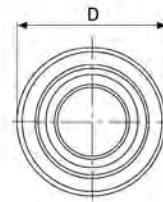
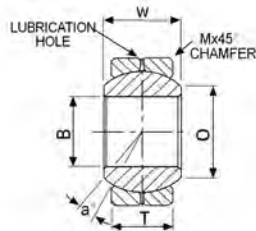

• MIB-T/AIB-T/SIB-T

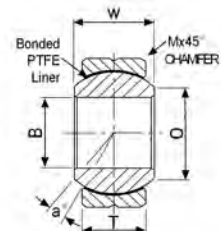

PART NUMBER			DIMENSIONS IN INCHES										
MIB	AIB	SIB	B +0.0015 -0.0005	D +0.0000 -0.0007	T +0.0000	W ±0.005	Ø Flat Dia. Ref.	M Chamfer Ref.	Ball Dia. Ref.	Misalign Angle a°	Ult. Radial Static Load Lbs.		Approx. Brg. Wgt. Lbs.
											MIB	AIB/SIB	
MIB3	AIB3	SIB3	0.1900	0.5312	0.250	0.312	0.307	0.020	0.437	10.5	4,370	6,555	0.02
MIB4	AIB4	SIB4	0.2500	0.6094	0.281	0.375	0.331	0.020	0.500	14.5	5,620	8,430	0.02
MIB5	AIB5	SIB5	0.3125	0.7500	0.344	0.437	0.448	0.020	0.625	11.0	8,600	12,900	0.04
MIB6	AIB6	SIB6	0.3750	0.8437	0.406	0.500	0.516	0.020	0.719	9.50	11,677	17,516	0.06
MIB7	AIB7	SIB7	0.4375	1.0000	0.437	0.562	0.587	0.020	0.812	11.0	14,194	21,291	0.08
MIB8	AIB8	SIB8	0.5000	1.0937	0.500	0.625	0.699	0.020	0.937	9.50	18,740	28,110	0.11
MIB10	AIB10	SIB10	0.6250	1.3125	0.562	0.750	0.839	0.030	1.125	12.0	25,290	37,935	0.17
MIB12	AIB12	SIB12	0.7500	1.5000	0.687	0.875	0.978	0.030	1.312	10.0	32,448	48,672	0.25
MIB16	AIB16	SIB16	1.0000	2.1250	1.000	1.375	1.275	0.060	1.875	15.0	60,000	90,000	0.79

Bearing No.			DIMENSIONS IN INCHES										
MIB-T	AIB-T	SIB-T	B +0.0015 -0.0005	D +0.0000 -0.0007	T +0.0000	W ±0.005	Ø Flat Dia. Ref.	M Chamfer Ref.	Ball Dia. Ref.	Misalign Angle a°	Ult. Radial Static Load Lbs.		Approx. Brg. Wgt. Lbs.
											MIB-T	AIB-T/SIB-T	
MIB3T	AIB3T	SIB3T	0.1900	0.5312	0.250	0.312	0.307	0.020	0.437	10.5	4,370	6,555	0.02
MIB4T	AIB4T	SIB4T	0.2500	0.6094	0.281	0.375	0.331	0.020	0.500	14.5	5,620	8,430	0.02
MIB5T	AIB5T	SIB5T	0.3125	0.7500	0.344	0.437	0.448	0.020	0.625	11.0	8,600	12,900	0.04
MIB6T	AIB6T	SIB6T	0.3750	0.8437	0.406	0.500	0.516	0.020	0.719	9.50	11,677	17,516	0.06
MIB7T	AIB7T	SIB7T	0.4375	1.0000	0.437	0.562	0.587	0.020	0.812	11.0	14,194	21,291	0.08
MIB8T	AIB8T	SIB8T	0.5000	1.0937	0.500	0.625	0.699	0.020	0.937	9.50	18,740	28,110	0.11
MIB10T	AIB10T	SIB10T	0.6250	1.3125	0.562	0.750	0.839	0.030	1.125	12.0	25,290	37,935	0.17
MIB12T	AIB12T	SIB12T	0.7500	1.5000	0.687	0.875	0.978	0.030	1.312	10.0	32,448	48,672	0.25
MIB16T	AIB16T	SIB16T	1.0000	2.1250	1.000	1.375	1.275	0.060	1.875	15.0	60,000	90,000	0.79

SGE..ET-2RS

Inner Race: 440C Stainless steel, heat treated,
precision ground

Outer Race: 304 Stainless steel, with liner of PTFE fabric

Sliding contact surfaces: Steel/PTFE fabric.

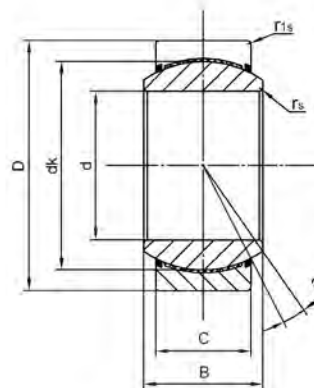

SGE..ET-2RS

Bearing No.	Dimensions(mm)							Load ratings KN		a° ≈	weight ≈ kg
	d	D	B	C	dk	r _s	r _{1s}	Dynamic	Static		
SGE15ET-2RS	15	26	12	9	22	0.3	0.3	25	50	8	0.027
SGE17ET-2RS	17	30	14	10	25	0.3	0.3	32	64	10	0.041
SGE20ET-2RS	20	35	16	12	29	0.3	0.3	45	90	9	0.066
SGE25ET-2RS	25	42	20	16	35.5	0.6	0.6	85	170	7	0.119
SGE30ET-2RS	30	47	22	18	40.7	0.6	0.6	110	220	6	0.153
SGE35ET-2RS	35	55	25	20	47	0.6	1	140	280	6	0.233
SGE40ET-2RS	40	62	28	22	53	0.6	1	175	350	7	0.306
SGE45ET-2RS	45	68	32	25	60	0.6	1	225	450	7	0.427
SGE50ET-2RS	50	75	35	28	66	0.6	1	275	550	6	0.546
SGE55ET-2RS	55	85	40	32	74	0.6	1	355	710	7	0.939
SGE60ET-2RS	60	90	44	36	80	1	1	430	860	6	1.04



SGE..C

Ball: 440C Stainless steel, heat treated, precision ground

Outer Race: 304 Stainless steel, with PTFE composite.

Sliding contact surfaces : Steel/ PTFE composite.

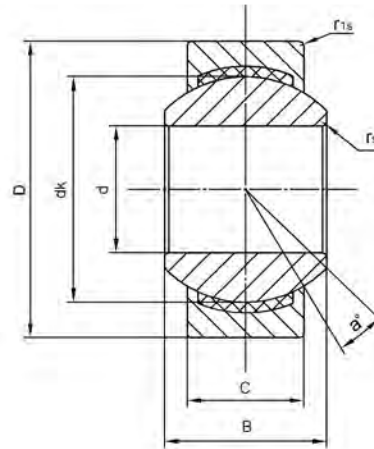

Bearing No.	Dimensions(mm)							Load ratings KN		a° ≈	weight ≈ kg
	d	D	B	C	dk	r _s min	r _{1s} min	Dynamic	Static		
SGE4C	4	12	5	3	8	0.3	0.3	2.1	5.4	16	0.003
SGE5C	5	14	6	4	10	0.3	0.3	3.6	9.1	13	0.005
SGE6C	6	14	6	4	10	0.3	0.3	3.6	9.1	13	0.004
SGE8C	8	16	8	5	13	0.3	0.3	5.8	14	15	0.008
SGE10C	10	19	9	6	16	0.3	0.3	8.6	21	12	0.011
SGE12C	12	22	10	7	18	0.3	0.3	11	28	10	0.015
SGE15C	15	26	12	9	22	0.3	0.3	18	45	8	0.027
SGE17C	17	30	14	10	25	0.3	0.3	22	56	10	0.041
SGE20C	20	35	16	12	29	0.3	0.3	31	78	9	0.066
SGE25C	25	42	20	16	35.5	0.6	0.6	51	127	7	0.119
SGE30C	30	47	22	18	40.7	0.6	0.6	65	166	6	0.163

SGE..PW

Ball: 440C Stainless steel,heat treated,precision ground

Outer Race: 304 Stainless steel, with liner of PTFE composite.

Sliding contact surfaces: Steel/PTFE Composite.

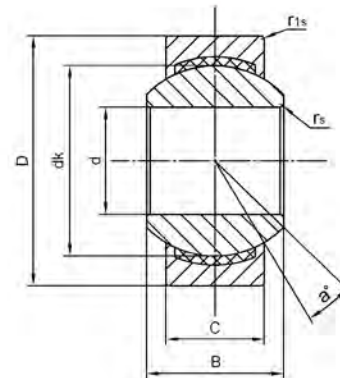

Bearing No.	Dimensions(mm)							Load ratings KN		a° ≈	weight ≈ kg
	d	D	B	C	dk	rs	r1s	Dynamic	Static		
SGE5PW	5	13	8	6	11.112	0.3	0.3	6	15	13	0.006
SGE6PW	6	16	9	6.75	12.7	0.3	0.3	7.65	19.3	13	0.010
SGE8PW	8	19	12	9	15.875	0.3	0.3	12.9	32	14	0.018
SGE10PW	10	22	14	10.5	19.05	0.3	0.3	18	45	13	0.027
SGE12PW	12	26	16	12	22.225	0.3	0.3	24	60	13	0.043
SGE14PW	14	28	19	13.5	25.4	0.3	0.3	31	76.5	16	0.055
SGE16PW	16	32	21	15	28.575	0.3	0.3	39	96.5	15	0.08
SGE18PW	18	35	23	16.5	31.75	0.3	0.3	47.5	118	15	0.10
SGE20PW	20	40	25	18	34.925	0.3	0.6	57	140	14	0.15
SGE22PW	22	42	28	20	38.1	0.3	0.6	68	170	15	0.18
SGE25PW	25	47	31	22	42.85	0.3	0.6	85	212	15	0.24
SGE30PW	30	55	37	25	50.8	0.3	0.6	114	285	17	0.38

TK..

Material: Gcr15, ball surface polished,
with or without hard chrome plating
are optional

Heat treatment: HRC58~64;

Stainless steel 440C is optional

Can custom made per customer's request.

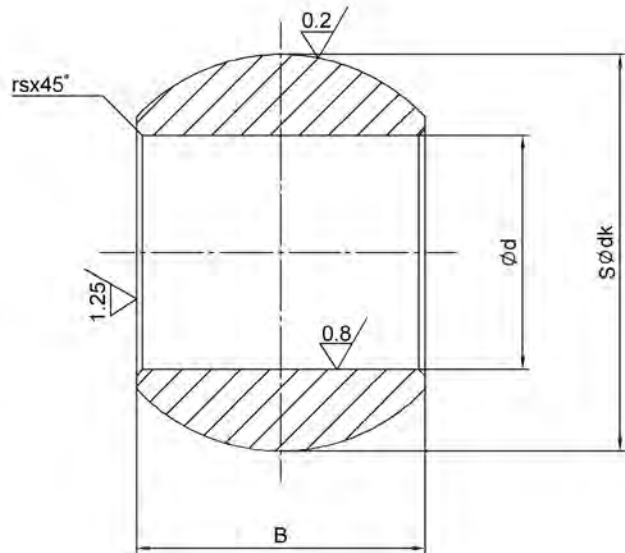

Bearing No.	Dim d	dk	B	rs min
TK5	$5^{+0.012}_0$	$11.11^{0}_{-0.03}$	$8^{0}_{-0.12}$	0.3
TK6	$6^{+0.012}_0$	$12.7^{0}_{-0.03}$	$9^{0}_{-0.12}$	0.3
TK8	$8^{+0.015}_0$	$15.88^{0}_{-0.03}$	$12^{0}_{-0.12}$	0.3
TK10	$10^{+0.015}_0$	$19.05^{0}_{-0.03}$	$14^{0}_{-0.12}$	0.6
TK12	$12^{+0.018}_0$	$22.23^{0}_{-0.03}$	$16^{0}_{-0.12}$	0.6
TK14	$14^{+0.018}_0$	$25.4^{0}_{-0.04}$	$19^{0}_{-0.12}$	0.6
TK16	$16^{+0.018}_0$	$28.58^{0}_{-0.04}$	$21^{0}_{-0.12}$	0.6
TK18	$18^{+0.018}_0$	$31.75^{0}_{-0.04}$	$23^{0}_{-0.12}$	0.6
TK20	$20^{+0.021}_0$	$34.93^{0}_{-0.04}$	$25^{0}_{-0.12}$	0.6
TK22	$22^{+0.021}_0$	$38.1^{0}_{-0.04}$	$28^{0}_{-0.12}$	0.6
TK25	$25^{+0.021}_0$	$42.86^{0}_{-0.04}$	$31^{0}_{-0.12}$	0.6
TK28	$28^{+0.021}_0$	$47.63^{0}_{-0.04}$	$35^{0}_{-0.12}$	0.6
TK30	$30^{+0.021}_0$	$50.8^{0}_{-0.04}$	$37^{0}_{-0.12}$	0.6

All dimensions are in MM.

CBL..DP

Material: Gcr15, ball surface polished,
with or without hard chrome plating
are optional

Heat treatment: HRC58~64;

Stainless steel 440C is optional

Can custom made per customer's request.

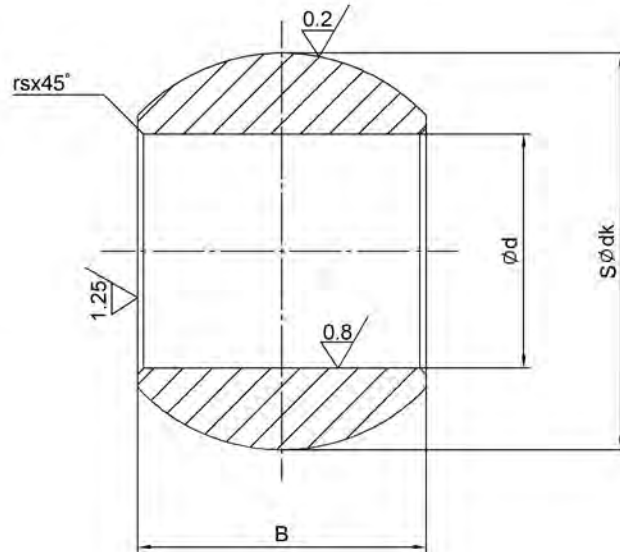

Dim Bearing No.	$d \begin{smallmatrix} +0.037 \\ -0.013 \end{smallmatrix}$	$dk \begin{smallmatrix} 0 \\ -0.03 \end{smallmatrix}$	$B \begin{smallmatrix} 0 \\ -0.012 \end{smallmatrix}$	rs min
CBL3DP	4.826	11.110	7.92	0.4
CBL4DP	6.350	12.700	9.53	0.4
CBL5DP	7.938	15.875	11.10	0.4
CBL6DP	9.525	18.256	12.70	0.7
CBL7DP	11.110	20.625	14.27	0.7
CBL8DP	12.700	23.812	15.88	0.7
CBL10DP	15.875	28.575	19.05	0.8
CBL12DP	19.050	33.338	22.23	0.8
CBL16DP	25.400	47.625	25.40	0.8

All dimensions are in MM.

HJMX..

Material: Gcr15, ball surface polished,
hard chrome plated

Heat treatment: HRC58~64;

Stainless steel 440C is optional

Can custom made per customer's request.

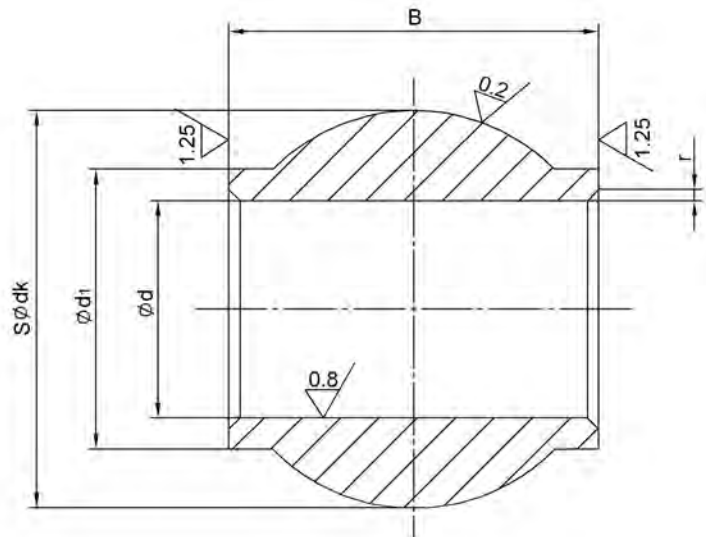

Bearing No.	Dim	$d \begin{smallmatrix} 0 \\ -0.013 \end{smallmatrix}$	d1	$dK \begin{smallmatrix} 0 \\ -0.03 \end{smallmatrix}$	$B \begin{smallmatrix} 0 \\ -0.12 \end{smallmatrix}$	rs min
HJMX6		9.525	13.00	19.84	20.65	0.7
HJMX7		11.110	15.70	22.23	22.23	0.7
HJMX8		12.700	18.54	25.40	23.80	0.7
HJMX10		15.875	21.74	31.75	30.48	0.8
HJMX12		19.050	24.64	34.93	32.51	0.8

All dimensions are in MM.

B-GE..C

Material: Gcr15, ball surface polished,
hard chrome plated

Heat treatment: HRC58~64;

Stainless steel 440C is optional

Can custom made per customer's request.

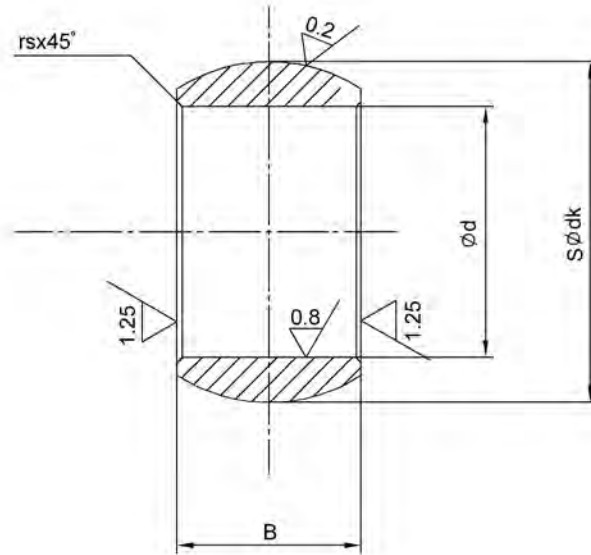

Bearing No.	Dim	d	dk	B	rs min
B-GE4C		4 ⁰ _{-0.008}	8 ⁰ _{-0.03}	5 ⁰ _{-0.12}	0.3
B-GE5C		5 ⁰ _{-0.008}	10 ⁰ _{-0.03}	5 ⁰ _{-0.12}	0.3
B-GE6C		6 ⁰ _{-0.008}	10 ⁰ _{-0.03}	5 ⁰ _{-0.12}	0.3
B-GE8C		8 ⁰ _{-0.008}	13 ⁰ _{-0.04}	5 ⁰ _{-0.12}	0.3
B-GE10C		10 ⁰ _{-0.008}	16 ⁰ _{-0.04}	5 ⁰ _{-0.12}	0.3
B-GE12C		12 ⁰ _{-0.008}	18 ⁰ _{-0.04}	5 ⁰ _{-0.12}	0.3
B-GE15C		15 ⁰ _{-0.008}	22 ⁰ _{-0.04}	5 ⁰ _{-0.12}	0.3
B-GE17C		17 ⁰ _{-0.008}	25 ⁰ _{-0.04}	5 ⁰ _{-0.12}	0.3
B-GE20C		20 ⁰ _{-0.010}	29 ⁰ _{-0.04}	5 ⁰ _{-0.12}	0.3
B-GE25C		25 ⁰ _{-0.010}	35.5 ⁰ _{-0.04}	5 ⁰ _{-0.12}	0.6
B-GE30C		30 ⁰ _{-0.010}	40.7 ⁰ _{-0.04}	5 ⁰ _{-0.12}	0.6

All dimensions are in MM.

B-COM..

Material: Gcr15, ball surface polished,
with or without hard chrome plating
are optional

Heat treatment: HRC58~64;

Stainless steel 440C is optional

Can custom made per customer's request.

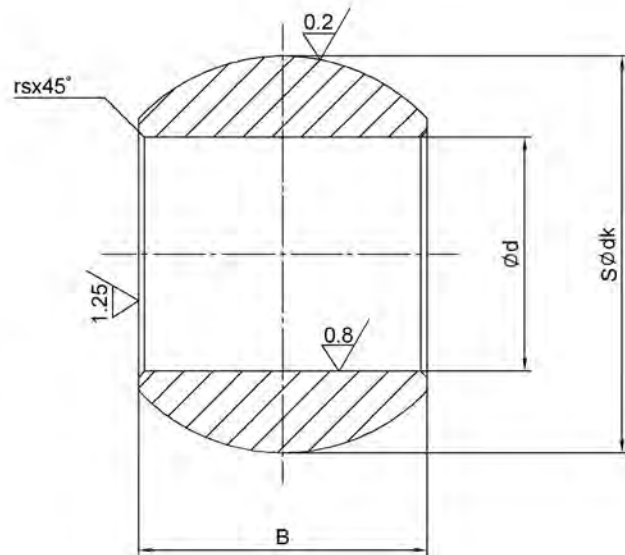

Bearing No.	Dim $d \begin{smallmatrix} +0.037 \\ -0.013 \end{smallmatrix}$	$dk \begin{smallmatrix} 0 \\ -0.03 \end{smallmatrix}$	$B \pm 0.013$	rs min
B-COM3	4.826	10.31	7.14	0.4
B-COM4	6.350	12.70	8.71	0.4
B-COM5	7.938	14.27	9.53	0.6
B-COM6	9.525	16.66	10.31	0.7
B-COM7	11.112	17.45	11.10	0.7
B-COM8	12.700	20.65	12.70	0.7
B-COM9	14.288	23.01	14.27	0.8
B-COM10	15.875	25.40	15.88	0.8
B-COM12	19.050	30.15	19.05	0.8
B-COM14	22.225	33.33	22.23	0.8
B-COM16	25.400	38.10	25.40	0.8

All dimensions are in MM.



INCH/METRIC CONVERSION TABLE

INCH		MM	INCH		MM	INCH		MM	INCH		MM
Fraction	Decimal		Fraction	Decimal		Fraction	Decimal		Fraction	Decimal	
	0.0004	0.001	17/64	0.2656	6.746		0.6693	17.0		1.3780	35.0
	0.00039	0.010		0.2756	7.0	43/64	0.6719	17.066		1.4173	36.0
	0.0010	0.025	9/32	0.2812	7.1437	11/16	0.6875	17.4625	1-1/2	1.5000	38.1
	0.0020	0.051	19/64	0.2969	7.5406	45/64	0.7031	17.859		1.5354	39.0
	0.0030	0.0762	5/16	0.3125	7.9375		0.7086	18		1.5748	40.0
	0.00394	0.1		0.3150	8.0	23/32	0.7187	18.256		1.6535	42.0
	0.0050	0.1270	21/64	0.3281	8.334	47/64	0.7344	18.653	1-3/4	1.7500	44.45
	0.00984	0.25	11/32	0.3437	8.731		0.7480	19.0		1.7717	45.0
	0.0100	0.254		0.3543	9.0	3/4	0.7500	19.05		1.8898	48.0
1/64	0.0156	0.396	23/64	0.3594	9.1281	49/64	0.7656	19.446		1.9685	50.0
1/32	0.0312	0.793	3/8	0.3750	9.525	25/32	0.7812	19.843	2	2.0000	50.8
	0.03937	1.0	25/64	0.3906	9.9219		0.7874	20.0		2.0472	52.0
3/64	0.0469	1.191		0.3937	10.0	51/64	0.7969	20.240		2.1654	55.0
	0.0591	1.5	13/32	0.4062	10.318	13/16	0.8125	20.6375		2.2047	56.0
1/16	0.0625	1.5875	27/64	0.4219	10.716		0.8268	21.0	2-1/4	2.2500	57.15
5/64	0.0781	1.984		0.4331	11.0	53/64	0.8281	21.034		2.3622	60.0
	0.0787	2.0	7/16	0.4375	11.1125	27/32	0.8437	21.431	2-1/2	2.5000	63.5
3/32	0.0937	2.381	29/64	0.4531	11.509	55/64	0.8594	21.828		2.5197	64.0
	0.0984	2.5	15/32	0.4687	11.906		0.8661	22.0	2-3/4	2.7500	69.85
	0.1000	2.54		0.4724	12.0	7/8	0.8750	22.225		2.8346	72.0
7/64	0.1094	2.778	31/64	0.4844	12.303	57/64	0.8906	22.621		2.9528	75.0
	0.1181	3.0	1/2	0.5000	12.7		0.9055	23.0	3.0	3.0000	76.2
1/8	0.125	3.175		0.5118	13.0	29/32	0.9062	23.018		3.1496	80.0
	0.1378	3.5	33/64	0.5156	13.096	59/64	0.9219	23.416	3-1/4	3.2500	82.55
9/64	0.1406	3.571	17/32	0.5312	13.493	15/16	0.9375	23.8125	3-1/2	3.5000	88.9
5/32	0.1562	3.968	35/64	0.5469	13.891		0.9449	24.0		3.5433	90.0
	0.1575	4.0		0.5512	14.0	61/64	0.9531	24.209	3-3/4	3.7500	95.25
11/64	0.1719	4.366	9/16	0.5625	14.2875	31/32	0.9687	24.606		3.9370	100.0
	0.1772	4.5	37/64	0.5781	14.684		0.9843	25.0	4	4.0000	101.6
3/16	0.1875	4.7625		0.5906	15.0	63/64	0.9844	25.003	4-1/4	4.2500	107.95
	0.1969	5.0	19/32	0.5937	15.081	1	1.0000	25.4		4.3307	110.0
13/64	0.2031	5.159	39/64	0.6094	15.478		1.0630	27.0	4-1/2	4.5000	114.3
7/32	0.2187	5.556	5/8	0.6250	15.875		1.1024	28.0		4.7244	120.0
15/64	0.2344	5.953		0.6299	16.0		1.1811	30.0	4-3/4	4.7500	120.65
	0.2362	6.0	41/64	0.6406	16.271	1-1/4	1.2500	31.75	5	5.0000	127.0
1/4	0.2500	6.35	21/32	0.6562	16.668		1.2992	33.0	5-1/2	5.5000	139.7

CONVERSION FACTORS

Inches	x 25.4	=Millimeters	Lbs. per in ²	x .0703	=Kg per cm ²
Millimeters	x .03937	=Inches	Kg per cm ²	x 14.2231	=Lbs. per in ²
Sq. Inches	x 6.4515	=Sq. Centimeters	Pounds (Force)	x 4.448	=Newtons
Sq. Centimeters	x .155	=Sq. Inches	Newtons	x .2248	=Pounds (Force)
Pounds	x .4536	=Kilograms	Degree C= (Degrees F -32) x .5556		
Kilograms	x 2.2046	=Pounds	Degree F= (Degrees C x 1.8) + 32		

INTERCHANGE TABLE 1

LDK	FK	ALINABAL	AURORA	HEIM/ BOSTON	MORSE/ SPHERCO	TUTHILL	NMB/ NHBB
MALE ROD ENDS							
CM	CM	AM-GP	CM	M-CR	CFM	MSM	AHM/LSPL
CM-T	CM-T	AM-T-GP	VCM		CFM-T	MSM-T	
CM-Y	CM-Y	AM-S-GP	CM-S	M-CRY	CFM-Y	MSM-S	
CM-Z	CM-Z	AM-8	CM-Z	M-CRG	CFM-N	MSM-Z	
CMX	CMX		RM-X5			MAX	
NJM	NJM	PM		CMHD	CTMD	NM/SPM	
JM	JM	LCTM-X5	MM/KM	HMA		MTSM	HAMR
JM-T	JM-T		MM-T/KM-T	HME	TRE-T	MTSM-T	AMRT
JMX	JMX	RM-X5	AM	BHM	ARE	TSMX	HAMRX
RJMX-T	RJMX-T		RAM-T			NSMX-T	
RSM	RSM	LCRM-1-X5	XM			RM	AXM
RSMX	RSMX	RM-1-X5	XAM			RMX	XAMX
RRSMX-T	RRSMX-T		RXAM-T				
HRSMX-T	HRSMX-T		HXAM-T				ARYT-ECR
PMX-T	PMX-T		PRM-T				ART-ES
NXM	KMX						
ALJM/ALJMH	ALJM/ALJMH	ARM-X5	ALM			KCA	ALRE
ALRSM	ALRSM	ARM-1-X5	XALM			KCAX	XALRE
SPOSB.EC	SCM-T		CM-ET			SSM-T	
SJM-T	SJM-T		SM-ET	ME		SSAM-T	ART-ECR
SRSMT	SRSMT					SSHMT	ARHT-ECR
FEMALE ROD ENDS							
CF	CF	AF-GP	CW	F-CR	CFF	MSF	AHF-CSPL
CF-T	CF-T	AF-T-GP	CW-T		CFF-T	MSF-T	
NJF	NJF	PF		CFHD	CTFD	NF/SPF	
JF	JF	CF	MW/KW	HFA		MTSF	HAFR
JF-T	JF-T		MW-T/KW-T	HFE	TR-T	MTSFT	AFRT
JFX	JFX		AW		AR	TSFX	HAFRX
ALJF	ALJF						
SPHSB.EC	SCF-T		CW-ET			SSF-T	
SJF-T	SJF-T		SW-ET			SSAF-T	ART-CR
SPHERICAL BEARINGS							
COM	COM	COM-E	COM	COM	COM	COM	CBG
HCOM	COMH		HCOM		BH-LS		RSH
YSSB	HIN-T		HAB-T			YSSB	ABYT
NSSB	FKSSX-T		NC-T	NE/LHSSE	NRR	NSSB	ABT
NSSB-V	FKSSX-TV		NC-TG	NE-G/LHSSV V	NRRG	NSSB-V	ABT-V
WSSB	WSSX-T		WC-T	WE	WRR	WSSB	ABWT
WSSB-V	WSSX-TV		WC-TG	WE-G	WRRG	WSSB-V	ABWT-V

INTERCHANGE TABLE 2

LDK	SKF	FAG	ELGES	ASK	LS	IKO	THK	LSK	MTR
SI..C	SI..C	SI..C	GIR..UK	EJ..D	SI..C			GIR..UK	
SI..ET 2RS	SAL..TE 2RS	SI..ES 2RS	GIR..UK 2RS	EJ..D 2RS	SI..ET 2RS			GIR..UK 2RS	
SA..C	SA..C	SA..C	GAR..UK	EA..D	SA..C			GAR..UK	
SA..ET 2RS	SAA..TE 2RS	SA..TE 2RS	GAR..UK 2RS	EA..D 2RS	SA..ET 2RS			GAR..UK	
SIL..C	SIL..C	SIL..C	GIL..UK	EJL..D	SIL..C			GIL..UK	
SIL..ET 2RS	SILA..TE 2RS	SIL..TE 2RS	GIL..UK 2RS	EJL..D 2RS	SIL..ET 2RS			GIL..UK 2RS	
SAL..C	SAL..C	SAL..C	GAL..UK	EAL..D	SAL..C			GAL..UK	
SAL..ET 2RS	SALA..TE 2RS	SAL..TE 2RS	GAL..UK 2RS	EAL..D 2RS	SAL..ET 2RS			GAL..UK 2RS	
SQ..RS					SQ..RS	LHSA..	RBL..		
SQ..L..RS					SQ..L..RS		RBL..L		
SQD..					SQD..		ABS..		
SQZ..RS					SQZ..RS		RBI..		
SQZL..RS					SQZL..RS		RBI..L		
SIR..ES	SIR..ES		GIHR-K..DO		SIR..ES				
SILR..ES	SILR..ES		GIHL-K..DO		SILR..ES				
SIGEW..ES	SIQG..ES		GIHN-K..LO		SIGEW..ES				
SK..ES	SC..ES		GK..DO		SK..ES				
SF..ES	SCF..ES		GF..DO		SF..ES				
SIQ..ES			GIHO-K..DO		SIQ..ES				
SI..E	SI..E	SI..E	GIR..DO	EJ..	SI..E			GIR..E	
SI..ES	SIA..ES	SI..ES	GIR..DO	EJ..	SI..ES			GIR..ES	
SI..ES 2RS	SLA..ES 2RS	SI..ES 2RS	GIR..DO 2RS	EJ..2RS	SI..ES 2RS			GIR..ES 2RS	
SA..	SA..E	SA..E	GAR..DO	EA..	SA..			GAR..E	
SA..ES	SAA..ES	SA..ES	GAR..DO	EA..	SA..ES			GAR..ES	
SA..ES 2RS	SAA..ES 2RS	SA..ES 2RS	GAR..DO 2RS	EA..2RS	SA..ES 2RS			GAR..ES 2RS	
SIL..E	SIL..E	SIL..E	GIL..DO	EJL..	SIL..E			GIL..E	
SIL..ES	SIL..ES	SIL..ES	GIL..DO	EJL..	SIL..ES			GIL..ES	
SIL..ES 2RS	SIAL..ES 2RS	SIL..ES 2RS	GIL..DO 2RS	EJL..2RS	SIL..ES 2RS			GIL..ES 2RS	
SAL..E	SAL..E	SAL..E	GAL..DO	EAL..	SAL..E			GAL..E	
SAL..ES	SALA..ES	SAL..ES	GAL..DO	EAL..	SAL..ES			GAL..ES	
SAL..ES 2RS	SALA..ES 2RS	SAL..ES 2RS	GAL..DO 2RS	EAL..2RS	SAL..ES 2RS			GAL..ES 2RS	
CHS	SIKB..F		GIKFR..FW	KI..-D	SIJK..C	PHS..EC		TSF..C	DF..
COS	SAKB..F		GAKFR..FW	KA..-D	SAJK..C	POS..EC		TSM..C	DM
CHSL	SILKB..F		GIKFL..PW	KIL..-D	SILJK..C	PHSL..EC		TSFL..C	DF..L
COSL	SALKB..F		GAKFL..PW	KAL..-D	SALJK..C	POSL..EC		TSML..C	SM..L
NPHS				KI..-BD			NHS..T		
NPOS				KA..-BD			NOS..T		
NPHS..L				KIL..-BD			NHS..TL		
NPOS..L				KAL..-BD			NOS..TL		
PHS..	SIKAC..M		GIKF..PB	KI..-NIRO	SIBP..S	PHS..	PHS..	TSF..	BNF..
POS..	SAKAC..M		GAKF..PB	SA..-NIRO	SABP..S	POS..	POS..	TSM..	BNM..
PHSL..	SILKAC..M		GIKL..PB	KIL..-NIRO	SILBP..S	PHSL..	PHS..	TSFL..	BNF..L
POSL..	SALKAC..M		GAKL..PB	KAL..-NIRO	SALBP..S	POSL..	POS..	TSML..	BNM..L
PHSB					SIZP..S				
POSB					SAZP..S				
PHSB..L					SILZP..S				
POSB..L					SALZP..S				
SPHS..EC									
SPOS..EC									
SCHS					SIJK..C/X				
SCOS					SAJK..C/X				
SCHSL					SILJK..C/X				
SCOSL					SALJK..C/X				



INTERCHANGE TABLE 3

LDK	SKF	FAG	ELGES	ASK	LS	IKO	NTN	NMB	CCVI
GE..E	GE..E	GE..E	GE..DO	GE..	GE..E	GE..E	SA1-..B	SBH..NS	GE..E
GE..ES	GE..ES	GE..ES	GE..DO	GE..	GE..ES	GE..ES	SA1-..B	SBH..S	GE..ES
GE..ES 2RS	GE..ES 2RS	GE..ES 2RS	GE..DO 2RS	GE..2RS	GE..ES 2RS	GE..ES 2RS	SA1-..BSS		GE..ES-2RS
GEG..E	GEH..E	GEH..E	GE..FO		GEG..E	GE..G			GE..FO
GEG..ES	GEH..ES	GEH..ES	GE..FO		GEG..ES	GE..GS			GE..FO
GEG..ES 2RS	GEH..ES 2RS	GEH..ES 2RS	GE..FO 2RS		GEG..ES 2RS	GE..GS 2RS			GE..FO-2RS
GEEW..ES	GEG..ES		GE..LO		GEEW..ES				GE..LO
GEEM..ES 2RS	GEM..ES 2RS		GE..HO 2RS		GEEM..ES 2RS				GE..HO-2RS
GE..C	GE..C	GE..C	GE..UK	GE..D	GE..C	GE..EC	SARI-		GE..UK
GE..ET/XT 2RS	GE..TE 2RS	GE..UA 2RS	GE..D 2RS	GE..D 2RS	GE..ET/XT-2RS				GE..UK-2RS
GEG..C	GEH..C	GEH..C	GE..FW		GEG..C				GE..FW
GEG..ET 2RS	GEH..TE 2RS		GE..FW 2RS		GEG..ET 2RS				GE..FW-2RS
GEBK..S					GEBK..S	PB			PB
GE..PW			GE..PW	G..D	GEBJ..C				
GAC..S	GAC..S		GE..SX		GAC..S	GACZ..S			GE..SX
GAC..T	GAC..F		GE..SW		GAC..T	GX..S			GE..SW
GACZ..S	GAZ..SA				GACZ..S	GX..T			
GX..S	GX..X		GE..AX		GX..S				GE..AX
GX..T			GE..AW		GX..T				GE..AW
SGE..C	GE..TGR								
SGEG..C	GEH..TGR								

NOTE:

This interchange table shows approximate equivalency. It is not intended that all manufacturers' products are functionally interchangeable in all applications. LDK Bearings reserves the right to change specifications and other information included in this catalog without notice. All information, data, and dimension tables in this catalog have been carefully compiled and thoroughly checked. However, no responsibility for possible errors or omissions can be assumed.

WARNING!

The manufacturer can not determine all applications of its products. It is up to the customer to determine a suitable part for their application. For assistance, please contact LDK's Engineering Department.

CERTIFICATES

Our company has set up the quality system according to the international standard of ISO9001.



THE INTERNATIONAL CERTIFICATION NETWORK

CERTIFICATE

IQNet and CQM
hereby certify that the organization

Xinyuan Bearing Industrial Co.,Ltd., Quanzhou

Director: Xiyu Industrial Zone, Heshi Town, Luojiang District, Quanzhou, Fujian, P.R.China
Certification Add: Xiyu Industrial Zone, Heshi Town, Luojiang District, Quanzhou, Fujian, P.R.China

Postcode.:362013

is in conformity with

ISO 9001:2008 Standard

This certificate is valid to the following product(s)/service:
Production of rod end bearings, spherical plain bearings

Issued on: 2012-08-16

Validity date: 2015-08-15

Registration Number: CN-00212Q14589R0S



Michael Drechsel
President of IQNet

Zhang Wei
President of CQM



IQNet Partners:

AFNOR Spain AFNOR Certification France AFNOR International Belgium ANSIL Mexico APICS Portugal CCC Capital
CENI Italy CQC China CQM China CQS Czech Republic Cui Cui Croatia DQS Belgium GRIFF Germany DS Denmark
ELOT Greece FTAI Brazil FOSKORPOLSKA Warszawa INTERTEC Colombia IANF Mexico INHORN Taiwan
Instituto Certification Federal IRAM Argentina JQA Japan KPI Korea MSZT Hungary NABE Norway NEM Ireland
NOR Federal Quality Assurance Institute NY Institute for Quality Excellence SCS Slovakia SCSQA (UK) International SCSA Switzerland
SIAI Slovenia TSI in Poltava Ukraine TSE Turkey TQSS Serbia

Agile is represented in the USA by: APQC Compliance CSQI (USA) Quality Gateway and QSA Inc

* The list of other partners valid in the scope of this certificate. Application of other list is possible under special certification conditions

